

## 关于施密特

施密特电梯有限公司引进全球先进的生产设备、电梯技术、严谨的制造工艺和科学管理理念融入中国电梯行业，为中国城市发展注入强劲的动力。

施密特电梯工厂位于重庆市大足区高新技术产业开发区，紧邻中国西部主动脉——渝蓉高速。公司占地面积约150亩，拥有现代化电梯研发制造基地，最高测试梯速度达8m/s。

自成立以来，施密特始终秉承安全舒适的设计生产理念，为全球市场提供各类电扶梯产品，同时可提供完善的加装电梯和更新改造解决方案，提升城市人居生活品质。目前，公司已在中国各省市自治区建立了多家办事机构，同时在全球各个国家和地区设立了服务网点。

## 施密特电梯有限公司 Schmidt Elevator Co., Ltd.

地址：重庆市大足区高新技术产业开发区  
Add: Dazu High-tech Industrial Development Zone, Chongqing  
电话 Tel: 023-43450000

全国服务热线：400-999-6525

E-mail: [smt@smtelev.com](mailto:smt@smtelev.com)  
<http://www.smtelev.com>

本书为一般信息出版物，我们保留随时更改产品设计和说明的权利，本书的任何字句，无论其字面意思或含义，对于任何产品及产品的用途和质量，或者任何购销合同条款的表述与更改均不承担任何责任。

This publication is for general informational purposes and we reserve the right at any time to alter product design and specification. No statement if contains should be construed as a warranty or condition, express or implied, as to any production, its fitness for any particular purpose of quality, or any modifications or representation of the term of any purchase agreement.

Copyright © 2022 Schmidt Elevator Corporation 版权所有



扫描二维码关注  
微信公众号



扫描二维码关注  
公司网站

2022年03月印刷  
Printed in March 2022



## SE6000-V家用电梯 SE6000-V Home lifts

智造舒适安全电梯专家  
Expert in intelligent manufacturing  
as well as comfort and safety elevators



## 赋予别墅生活更多价值

Great more value on villa life

施密特家用电梯始终追求打造极致的别墅上下生活体验，以智能技术的革新，人性生活的设计，艺术品般的苛求，使您的别墅生活获得更多价值。

Schmidt Home lifts strives to create the best villa life experience all the time, makes your villa life more valuable by intelligent technology revolution, human lift design and artwork pursuit.



# 家用电梯

## Home lifts

### 品质生活, 优雅尊享

Elegant and graceful quality life

施密特家用电梯, 秉承电梯领域顶尖技术, 传承国际经典设计理念, 融汇艺术性, 实用性与时代性于一体, 与别墅、私人豪宅的高层次品味十分吻合。

Schmidt home lifts, adhering to the area of the elevator technology, classic design heritage of the international fusion of artistic, practical and integrated with the times, and Villas, private luxury high-level taste is very consistent.

### 多种开门方式, 选择不同品位生活

施密特家用电梯, 采用多种开门方式供用户选择, 同时可根据用户的需求和使用情况专门设计。

#### Alternative door styles, different choice

Varies of kinds door open style provided for you, you can choose any one of them as per your needs for your building requirement.

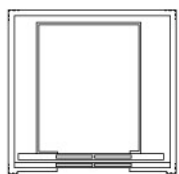

中分式  
Center-opening

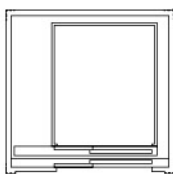

旁开式  
Side-opening

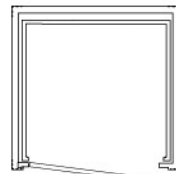

手拉式  
Manually operated door

### 人性化设计的四大优势

- 环保节能: 220V 或 380V 的电压, 耗电量相当于一台空调
- 产品特点: 浅底坑、可无土建井道, 美观、舒适
- 适用场所: 不同风格、不同结构的别墅
- 风格外观: 适合各种装修风格

#### Four advantages of the human design

Environmental protection and energy-saving: It uses 220V or 380 V voltage. Its power consumption is equal to that of a air conditioning.  
The product features: No pit, no construction well, it is attractive and comfortable.  
The applicable occasions: Different styles and structures of the villas.  
Style of appearance: for a variety of decoration style.



### 紧凑型结构

顶层空间的布局能够适合更多环境, 最小可在 1000×900mm 的井道内安装, 顶层高度最小 2700mm(曳引机下置), 底坑深度 ≥ 300mm。

#### Compact structure

The layout of the top floor can be suitable for various environment, the villa lift could be installed inside the shaft with the minimum size of 1000×900mm, the minimum overhead is 2700mm (traction machine down layout), the pit depth is no less than 300mm.

### 多样化布置

根据特定土建情况, 施密特家用电梯将通过开门方式、对重结构、曳引机布置、控制柜布置等多种布置方式满足客户需求。

#### Various layout

Depend on the specific shaft condition, Schmidt home lifts will meet clients requirement by various layout of door opening type, CWT structure, traction machine layout, controller layout.

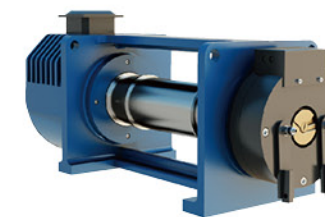

### 动力系统

永磁电机技术和进口轴承, 噪音低, 可用 220V 专用主机, 在常规电压下即可完成运载使命, 实际耗电量几乎与空调持平。

#### Power system

Aluminum shell and imported bearings, low noise, usable 220V dedicated host, the conventional voltage to complete the mission, the actual power consumption is almost flat with the refrigerator.



### 一体化设计 (可选)

钢带主机使驱动轮和电机轴杆融为一体, 更加小巧, 传动性能显著提高。

#### Integrated design (optional)

The steel stripe traction machine integrates the driving wheel and motor shaft, more compact, significantly improves the transmission performance.

# 安全电梯典范

## Safety elevator classic

赋予别墅生活更多价值

Great more value on villa life

施密特家用电梯始终追求打造极致的别墅上下生活体验，以智能技术的革新，人性生活的设计，艺术品般的苛求，使您的别墅生活获得更多价值。

Schmidt home lifts strives to create the best villa life experience all the time, makes your villa life more valuable by intelligent technology revolution, human lift design and artwork pursuit.



## 远程监控服务体系

通过物联网技术，施密特家用电梯实现了监控平台、客服团队、维保团队的三方高效联动，形成电梯安全的坚固屏障，完美实现全方位定制化的高端安全服务。

### Remote monitoring service system

By using the internet of things technology, Schmidt home lifts realizes the high efficient linkage among monitoring platform, customer service team, maintenance team, build up the strong elevator safety barrier, perfectly realizes the full-customized high end safety service.



## Schmidt APP

Schmidt APP 还具有 7\*24 小时全时安防功能，通过手机 APP，您还能看到电梯内的实时情况，让您每一刻都能守护家人安全。

### Schmidt APP

Schmidt APP also has the 7\*24 hours full-time function, through the mobile phone APP, you can see the real-time situation inside the cabin, so you can protect your family every moment.

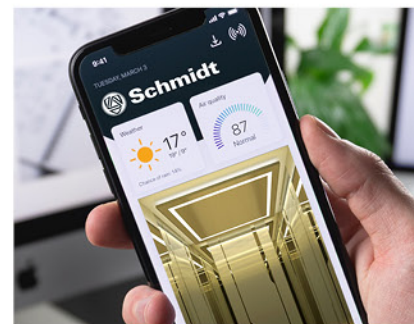

## ARD 停电应急装置

为防止意外停电关人，电梯采用 ARD 应急平层电源，确保在突然断电后，能让电梯仍有足够的电力将乘客安全的送到最近的层站。

### ARD Power failure emergency device

To prevent accidental power failure, the elevator can be used ARD emergency flat layer power, to ensure the power suddenly power off, can let the elevator still has enough power to the safety of the passengers to the nearest station.

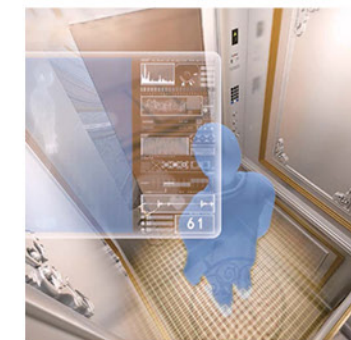

## 人体红外感应功能

当通过人体红外感应监测到乘客在电梯内停留 5 分钟以上，将会主动报警，确保乘客发生紧急情况及时发现，随时呵护家人安全。

### Body infrared induction function

When infrared induction of human body monitors that passengers have been kept in the villa lift for more than 5 minutes, the system will take the initiative to alarm. Ensure the passenger's emergency is found in time, and keep your family safe at any time.

# 曳引式家用电梯

## Traction Type Home lifts

### 曳引式家用电梯的特点

- 无需传统机房：节省建筑成本
- 可根据房屋结构的开门需求采用龙门架式电梯结构
- VVVF 驱动技术：家用电梯专用微机及变频驱动控制，平稳舒适
- 专用曳引机机架：固定于导轨，建筑物可不承受力
- 主机：可采用 220V 单相电源，普通家用电，无需另外申请工业电源
- 自动专用门机：变频节能，安全可靠
- UPS（后备电源）在停电时可以应急放人

### Characteristics of a traction type Home lifts

It does not need machine room. It saves the building cost.  
 It applies gantry style elevator structure according to door opening requirements of the housing structure.  
 VVVF drive technology: Home lifts dedicated micro-computer control is smooth and comfortable.  
 Special traction machine base frame is fixed on guiderail. The building does not bear any load.  
 Machine: It can apply 220V single-phase power supply of ordinary family use. It does not need to apply for industrial power supply.  
 Automatic door operator: Variable frequency energy-saving, safe and reliable  
 UPS (backup) can release the passengers during power failure.

### 内转子曳引主机，小巧轻便

- 曳引轮双支撑式结构，运行更稳定
- 别墅梯的理想选择，节能环保、噪音小、性价比高

### Inner rotor traction machine, small, light and convenient

Double-support structure of traction wheel for more stable operation  
 Home lifts ideal choice, energy conservation and environmental protection, low noise, cost-effective

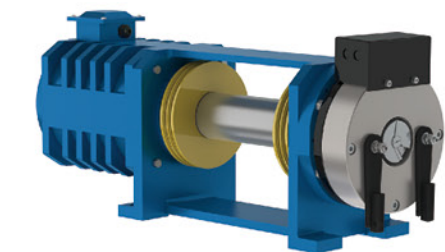

# 强驱式家用电梯

## Strong Drive Home lifts

采用先进的电梯强制式驱动和数字化控制变频调整技术，运行平稳。无需对重，无齿轮箱，体积小，安装简便，完全可以实现无机房设计，相比较传统液压梯，节省成本，更节约空间。

Applies the advanced elevator forced-drive and digital control variable frequency speed governor technology with smooth running . It needs no counterweight, no gear-box with small bulk, simple and convenient installation. It fully fulfills machine room-less. Compared with the traditional hydraulic elevator, is saves the cost and space.

### 强驱主机，极致空间

- 强驱主机无需配对重
- 强驱主机比常规主机大大节约了井道空间，满足更小空间要求

### Strong traction machine, extreme space

Hard drive hosts do not need to be paired  
 The forced drive main engine saves the well space greatly compared with the conventional main engine



# 轿厢装饰和设计

## Car decoration and design

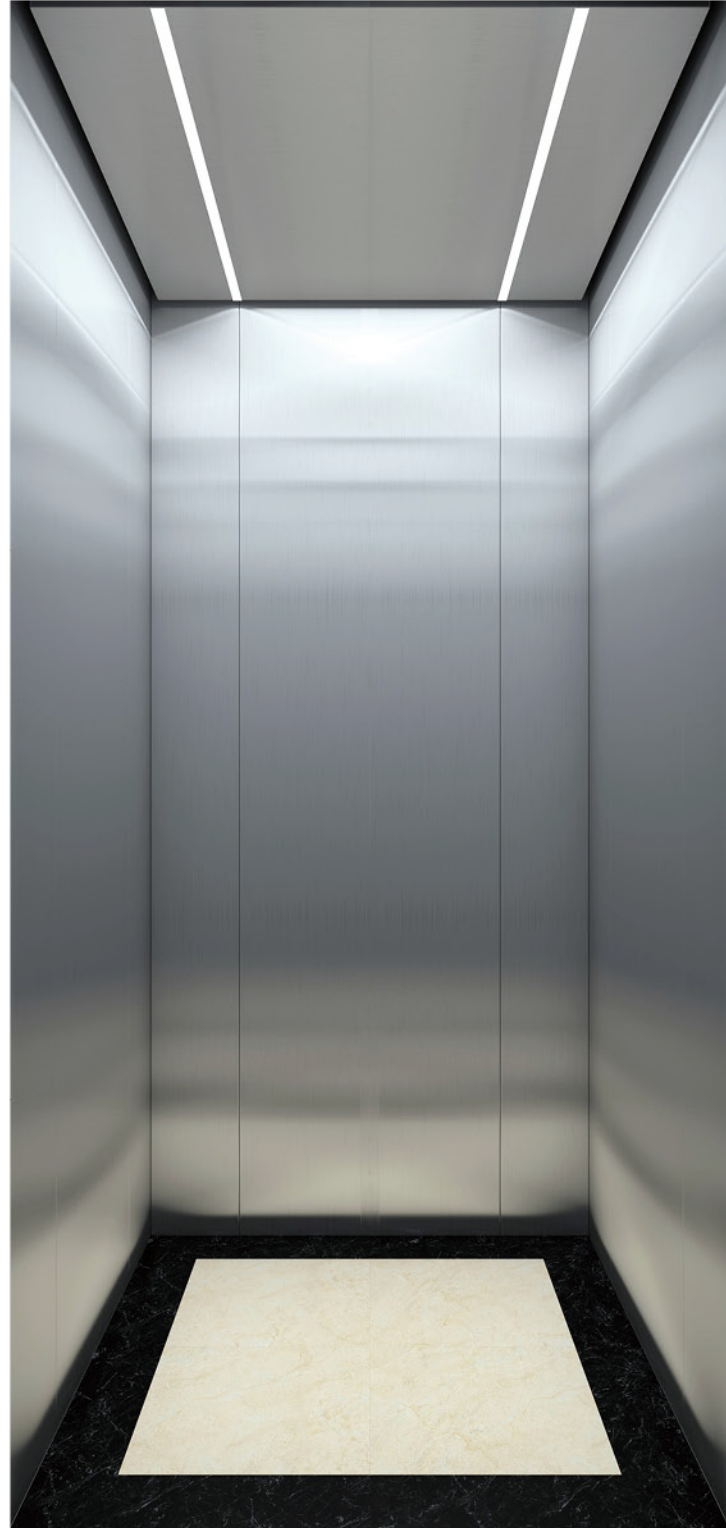

### SV200-1

吊顶：发纹不锈钢，灯带 (SV200-DD163)

前壁：发纹不锈钢

侧壁：发纹不锈钢

后壁：发纹不锈钢

地板：PVC/磁砖 (SV200-DB300)



不锈钢



钛金



玫瑰金



多种款式轿厢  
360° 全景展示



更多轿厢样式请扫描二维码

图片系电脑绘制，可能与实际图有不同，具体以实物为准。  
The computer-drawn pictures are only for reference.

# 轿厢装饰和设计

## Car decoration and design



多种款式轿厢  
360° 全景展示

### SV200-3

吊顶：古铜不锈钢，灯带 (SV200-DD175)

前壁：古铜不锈钢

侧壁：古铜不锈钢

后壁：古铜不锈钢 + 镜面蚀刻不锈钢

地板：PVC/磁砖 (SV200-DB300)



古铜



玫瑰金



钛金

图片系电脑绘制，可能与实际图有不同，具体以实物为准。  
The computer-drawn pictures are only for reference.

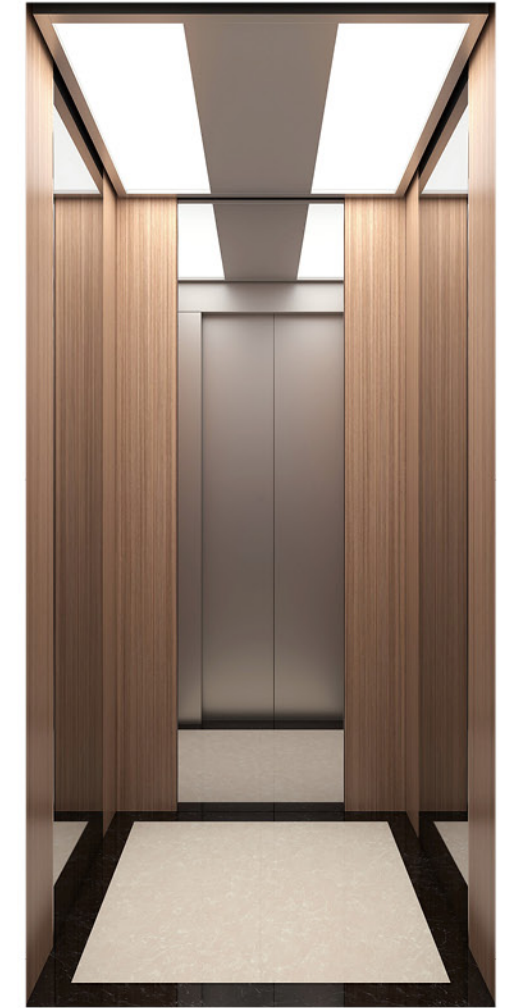

多种款式轿厢  
360° 全景展示

### SV200-6

吊顶：发纹不锈钢，  
亚克力 (SV200-DD168)

前壁：发纹不锈钢

侧壁：木饰面，镜面不锈钢

后壁：木饰面，镜面不锈钢

地板：PVC/磁砖 (SV200-DB302)



橡木



柚木

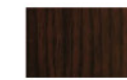

胡桃木

# 轿厢装饰和设计

## Car decoration and design



多种款式轿厢  
360° 全景展示

### SV200-8

-  吊顶: 发纹不锈钢 + 筒灯 (S-D177)
-  前壁: 钛金发纹不锈钢
-  侧壁: 镜面不锈钢 + 皮纹板
-  后壁: 镜面不锈钢 + 皮纹板
-  地板: PVC/ 磁砖 (SV200-DB303)

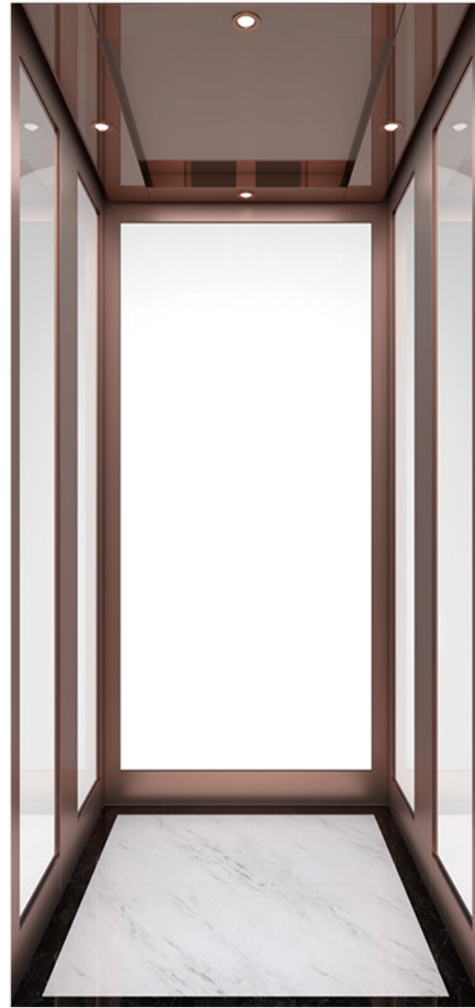
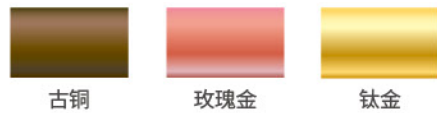

多种款式轿厢  
360° 全景展示

### SV200-10

-  吊顶: 玫瑰金镜面不锈钢, 筒灯 (SV200-DD179)
-  前壁: 玫瑰金不锈钢
-  侧壁: 玫瑰金不锈钢, 夹胶玻璃
-  后壁: 玫瑰金不锈钢, 夹胶玻璃
-  地板: PVC/ 磁砖 (SV200-DB305)

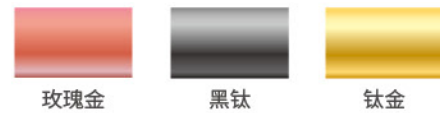

图片系电脑绘制, 可能与实际图有不同, 具体以实物为准。  
The computer-drawn pictures are only for reference.

# 人机界面

## Human-machine interface

### 外呼控制



LOP-V01 (标配)



LOP-V02 (选配)



COP-V01 (标配)

一体式  
前壁 ≥ 200mm

颜色可随轿厢颜色匹配

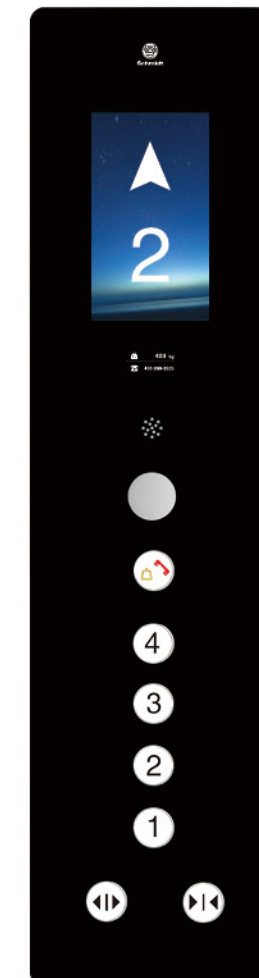

COP-V02 (选配)

分体式

抗指纹黑钛镜面不锈钢, 颜色不可选



COP-V03 (选配)

分体式触摸屏

图片系电脑绘制, 可能与实际图有不同。  
The pictures are plotted by computer and are likely somewhat different from the actual products.

# 厅门系列 (可选)

## Landing door series (optional)



**S-TM602**  
厅门: 发纹不锈钢  
大门套: 发纹不锈钢



**S-TM603**  
厅门: 镜面不锈钢  
幕板式大门套: 镜面不锈钢



**S-TM605**  
厅门: 镀钛蚀刻不锈钢  
幕板式斜角大门套: 镀钛不锈钢

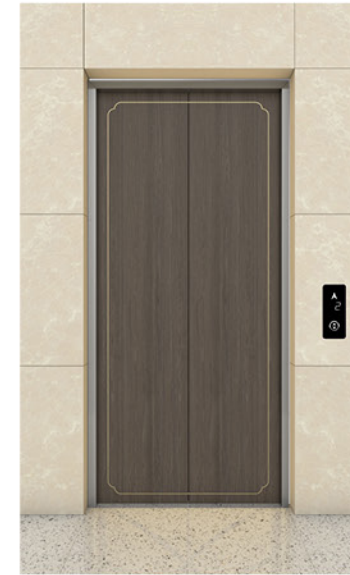

**S-TM610**  
木纹钢板



**S-TM611**  
木纹钢板



**S-TM612**  
木纹钢板

### 可选蚀刻不锈钢



**S-SK702**

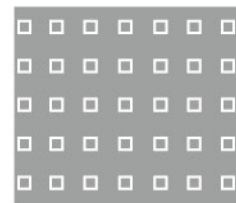

**S-SK703**

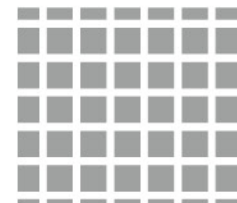

**S-SK707**

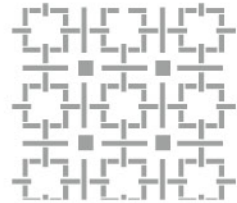

**S-SK709**



**S-SK710**



**S-SK711**

### 常规金属材质

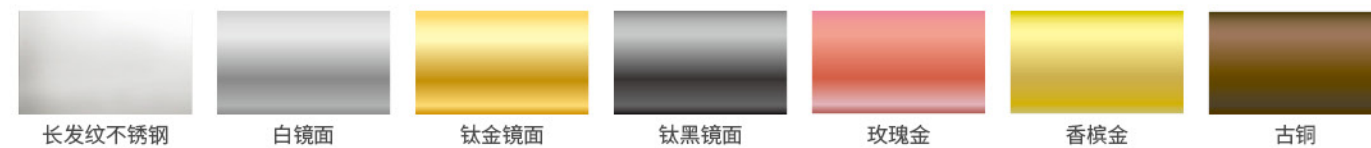

### 半自动门系列



**S-TM613**  
炫彩银色

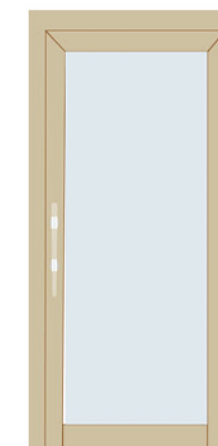

**S-TM615**  
香槟金



**S-TM616**  
黑胡桃色



**S-TM617**  
红木纹色



## 地板 (可选) Floor (optional)

拼花 PVC 地板  
Optional PVC floor



S-DB211

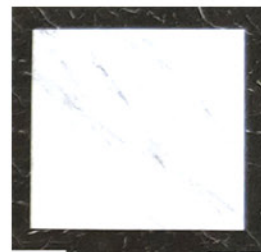

S-DB212

拼花磁砖地坪  
Optional Marble floor



S-DB218

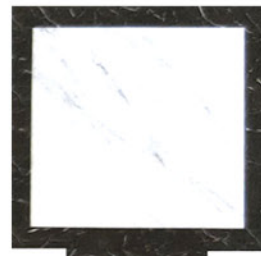

S-DB219

## 全面保护

- 关门时间保护
- 轿内紧急照明
- 限位保护
- 光幕门保护装置
- 轿顶与控制柜紧急电动运行
- 故障自动检测功能
- 撞底缓冲装置
- 门区外不能开门
- 抱闸检测保护
- 接触器反馈检测功能
- 继电器检查保护
- 速度反馈检测功能
- 逆向运行保护

- 外召按钮嵌入自诊断
- 故障低速自救功能
- 防打滑保护
- 安全回路保护
- 超载不启动
- 上下极限保护装置
- 门连锁保护
- 运行接触器保护
- 电网电压波动检测功能
- 驱动设备过热保护
- 电动松闸
- 停电应急平层 (ARD)
- 一键拨号功能

## 平稳运行

- 无呼自返基站功能
- 全集选控制
- 待梯层设定
- 自动开关门 (自动门)
- 预转矩输出
- 井道自学习
- 端站换速及楼层号校正
- 困人对外呼救

## 舒适乘行

- 设置厅、轿门时间 (自动门)
- 开、关门按钮 (自动门)
- 轿内通风自动及照明自动控制功能
- 本层外召唤门 (自动门)
- 不停层设置
- 重复关门 (自动门)
- 输入口干扰评价
- 手动选层
- 误登陆取消
- 晕厥误关自动呼救功能
- 防溜车主机双抱闸封星
- 系统一键自检解困

注: ○ 为选配功能

## 信息显示

- 厅外数字式位置指示器
- 轿厢数字式位置指示器
- 轿厢运行方向显示
- 楼层显示字符的预约设定
- 厅和轿厢呼梯 / 登记
- 运行次数显示功能
- 厅外运行方向显示

## 保安监控

- CCTV 电缆 (轿厢到机房)
- 电梯远程监控

# 土建规格及尺寸

## Layout specifications and dimensions

备注：标准层高 3 米，所有井道尺寸均为最小值  
Note: Standard floor height is 3m

### SV200-1

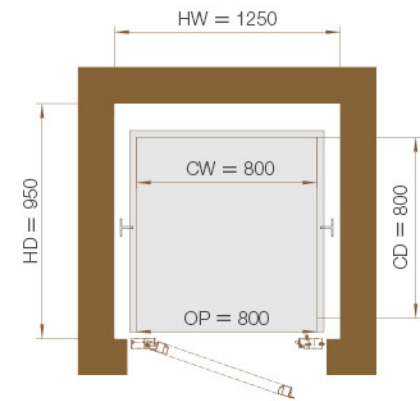

3 人 / 260 公斤

井道尺寸: HW × HD 1250 × 950 轿厢尺寸: CW × CD, OP 800 × 800, 800

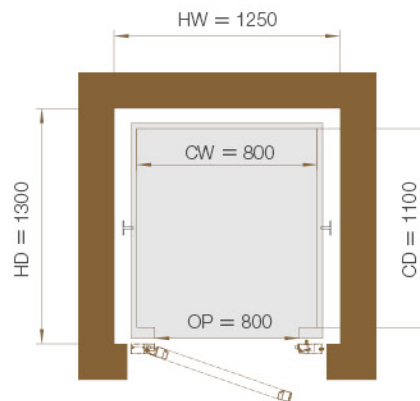

4 人 / 320 公斤

井道尺寸: HW × HD 1250 × 1300 轿厢尺寸: CW × CD, OP 800 × 1100, 800

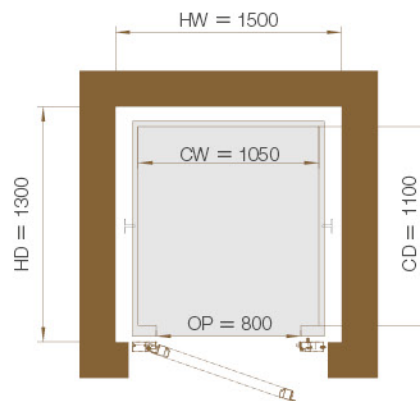

5 人 / 400 公斤

井道尺寸: HW × HD 1500 × 1300 轿厢尺寸: CW × CD, OP 1050 × 1100, 800

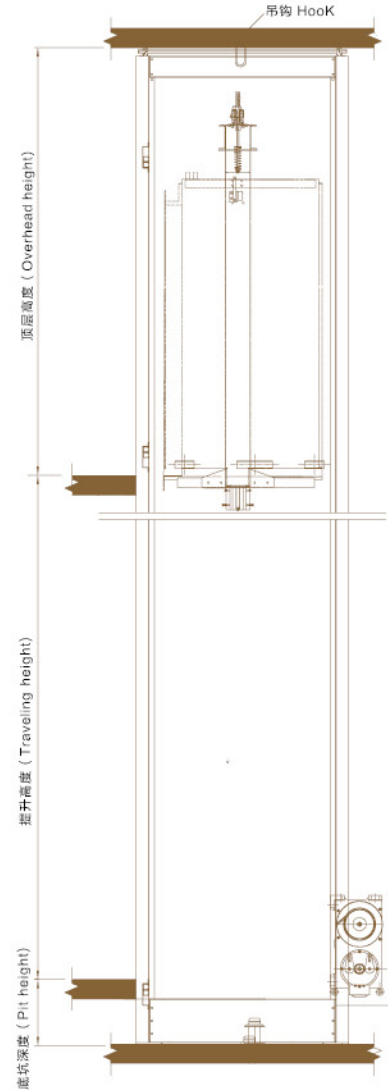

### SV200-1

- 载重: 260kg, 320kg, 400kg
- 速度: 0.3m/s
- 轿厢高度: 2200mm
- 开门高度: 2000mm
- 顶层高度: ≥ 3200mm
- 底坑深度: ≥ 300mm
- 提升高度: ≤ 15000mm

注：本样本所示图纸及规格参数仅供参考，订货请与公司确认。  
Note: the drawings and specifications shown on sample are only for your reference, any order please confirm with glarie company.

### SV200-2

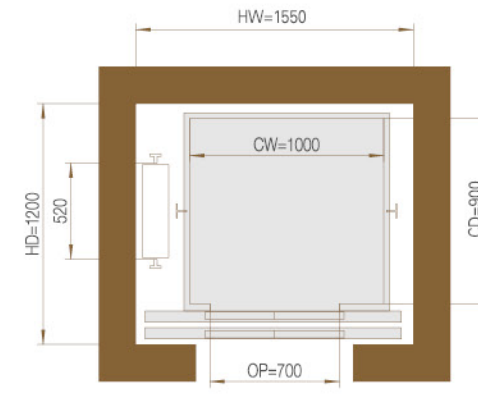

3 人 / 260 公斤

井道尺寸: HW × HD 1550 × 1200 轿厢尺寸: CW × CD, OP 1000 × 900, 700

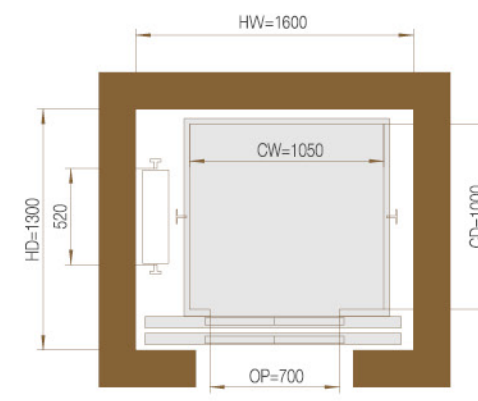

4 人 / 320 公斤

井道尺寸: HW × HD 1600 × 1300 轿厢尺寸: CW × CD, OP 1050 × 1000, 700

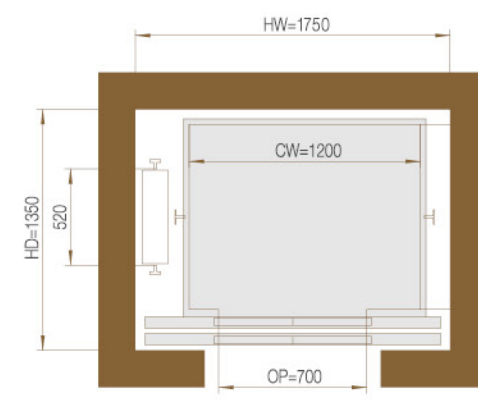

5 人 / 400 公斤

井道尺寸: HW × HD 1750 × 1350 轿厢尺寸: CW × CD, OP 1200 × 1000, 700

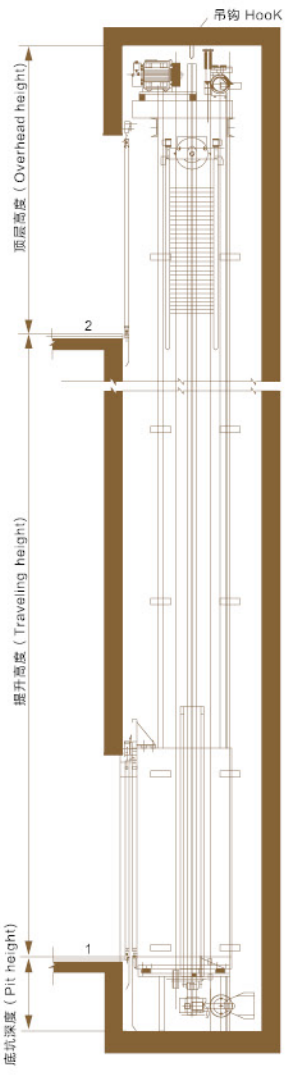

### SV200-2

- 载重: 260kg, 320kg, 400kg
- 速度: 0.4m/s
- 轿厢高度: 2200mm
- 开门高度: 2000mm
- 顶层高度: ≥ 3300mm
- 底坑深度: ≥ 300mm
- 提升高度: ≤ 15000mm

注：本样本所示图纸及规格参数仅供参考，订货请与公司确认。  
Note: the drawings and specifications shown on sample are only for your reference, any order please confirm with glarie company.