

SYD3065SLW、SYD3065SLA、SYD3065SLB、SYD3065SLP、是 30A, 650V 高可靠性 IGBT 晶体管，具有高速开关特性、及低导通损耗和开关损耗等特点。该产品可应用于逆变器、UPS 等领域

主要特征:

- 30A , 650V , $V_{CE(sat)}=1.7V @I_C=30A$
- 饱和压降为正温度系数, 易于并联使用
- 低导通损耗
- 内置快恢复二极管
- 高速开关特性
- 高可靠性及热稳定性, 良好的参数一致性
- 最小抗短路时间 5 μ s

产品规格分类:

型号 #	打标名称	封装
SYD3065SLW	SYD3065SLW	TO-247
SYD3065SLA	SYD3065SLA	TO-220F
SYD3065SLB	SYD3065SLB	TO-220
SYD3065SLP	SYD3065SLP	TO-263

封装符号:

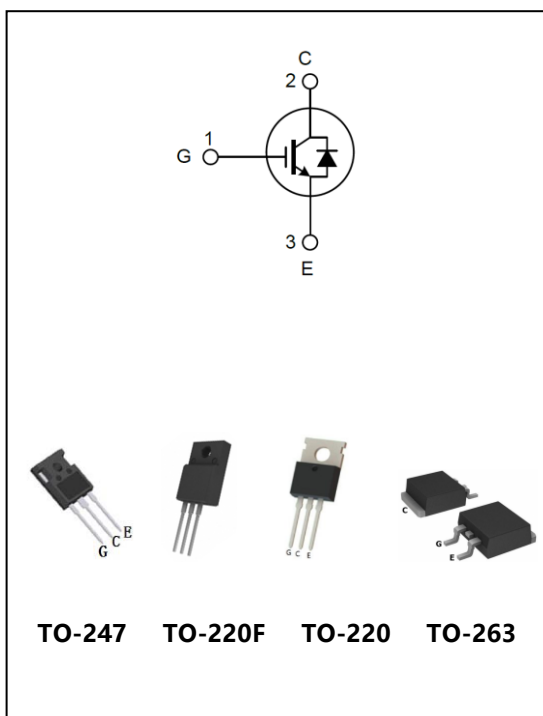

极限参数 (除非另有说明, $T_A = 25^{\circ}C$) :

符号	参数	参数范围	单位
V_{CE}	集电极-发射极电压	650	V
V_{GE}	栅极-发射极电压	± 20	V
I_C	集电极电流 ($T_C=25^{\circ}C$)	60	A
	集电极电流 ($T_C=100^{\circ}C$)	30	A
I_{Cpuls}	集电极脉冲电流	90	A
P_{tot}	耗散功率 ($T_C=25^{\circ}C$) ~ TO-247	142	W
	耗散功率 ($T_C=100^{\circ}C$) ~ TO-247	57	W



P_{tot}	耗散功率 (T _c =25°C) ~ TO-220F	50	W
	耗散功率 (T _c =100°C) ~ TO-220F	20	W
P_{tot}	耗散功率 (T _c =25°C) ~ TO-220	138	W
	耗散功率 (T _c =100°C) ~ TO-220	55	W
P_{tot}	耗散功率 (T _c =25°C) ~ TO-263	129	W
	耗散功率 (T _c =100°C) ~ TO-263	52	W
T_J	最高结温	-55~150	°C
T_{STG}	存储温度	-55~150	°C
R_{thjc}	IGBT芯片至管壳热阻 ~TO-247	0.88	K/W
	IGBT芯片至管壳热阻 TO-220F	2.50	K/W
	IGBT芯片至管壳热阻 TO-220	0.9	K/W
	IGBT芯片至管壳热阻 TO-263	0.97	K/W
R_{thjcD}	体二极管芯片至管壳热阻 ~TO-247	1.60	K/W
	体二极管芯片至管壳热阻 TO-220F	5.2	K/W
	体二极管芯片至管壳热阻 TO-220	1.60	K/W
	体二极管芯片至管壳热阻 TO-263	1.70	K/W
R_{thjA}	结到空气热阻~TO-247	40	K/W
	结到空气热阻 TO-220F	62.5	K/W
	结到空气热阻 TO-220	62	K/W
	结到空气热阻 TO-263	62	K/W

表 1: 极限参数



SYD3065SLW(A/B/P)

IGBT 晶体管 规格书 Rev 0.5

电气参数(除非另有说明, $T_A = 25^\circ\text{C}$):

符号	参数	最小	典型	最大	单位	测试条件
B_{VCE}	集射极击穿电压	650	---	---	V	$V_{GE}=0V, I_C=100\mu A$
I_{CES}	集射漏电流	---	---	1	μA	$V_{CE}=650V, V_{GE}=0V$
I_{GES}	栅射漏电流	---	---	± 100	nA	$V_{GE}=\pm 25V, V_{CE}=0V$
$V_{GE(th)}$	栅极开启电压	5.2	6.0	6.8	V	$I_C=250\mu A, V_{CE}=V_{GE}$
$V_{CE(sat)}$	导通饱和压降	---	1.7	---	V	$I_C=30A, V_{GE}=15V$
$V_{CE(sat)}$		---	2	---	V	$I_C=30A, V_{GE}=15V, T_C=125^\circ\text{C}$
C_{ies}	输入电容	---	2230	---	pF	$V_{CE}=30V$ $V_{GE}=0V$ $f=1\text{MHz}$
C_{oes}	输出电容	---	97.0	---	pF	
C_{res}	反向传输电容	---	45.0	---	pF	
Q_g	栅电荷	---	115	---	nC	$V_{CE}=400V,$ $I_C=30A,$ $V_{GE}=15V$
Q_{ge}	发射极栅电荷	---	21.0	---	nC	
Q_{gc}	集电极栅电荷	---	80.0	---	nC	

表 2: IGBT 参数

FRD 电气参数(除非另有说明, $T_A = 25^\circ\text{C}$):

V_F	二极管正向压降($T_C=25^\circ\text{C}$)	---	1.5	---	V	$I_F=30A$
T_{rr}	二极管反向恢复时间	---	98	---	ns	$I_{ES}=30A,$ $dI_{ES}/dt = 200A/\mu s$
I_R	瞬态反向漏电流	---	---	10	μA	$V_R=600V,$ $T_a=25^\circ\text{C}$

表 3: FRD 参数



开关特性参数(除非另有说明, $T_A = 25^\circ\text{C}$):

t_{on}	开通延时	---	52	---	ns	V _{CE} =400V I _C =30A R _g =10Ω V _{GE} =15V 感性负载
t_{off}	关断延时	---	146	---	ns	
t_r	开启上升时间	---	92	---	ns	
t_f	关断下降时间	---	41	---	ns	
E _{on}	导通损耗	---	1.54	---	mJ	
E _{off}	关断损耗	---	0.75	---	mJ	
Est	开关损耗	---	2.29	---	mJ	
T _{sc}	抗短路时间	5	---	---	μs	

表 4: 开关特性参数

典型特性曲线图(除非另有说明, $T_A = 25^\circ\text{C}$):

Output Characteristics

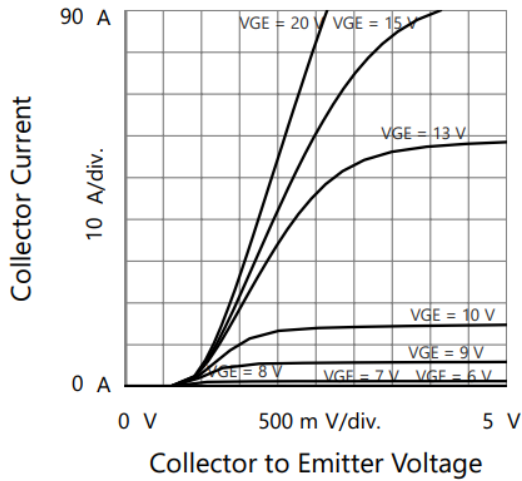

Transfer Characteristics

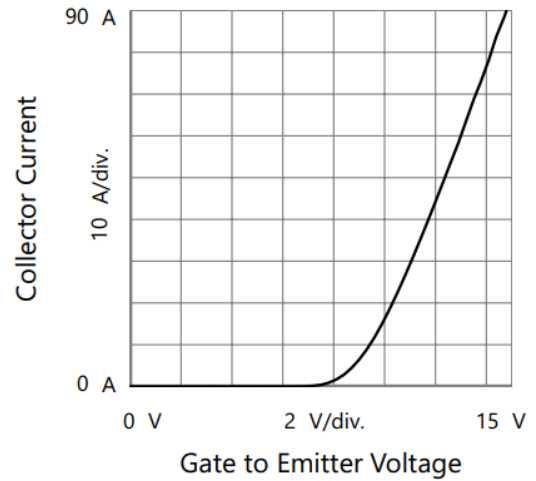

Capacitances

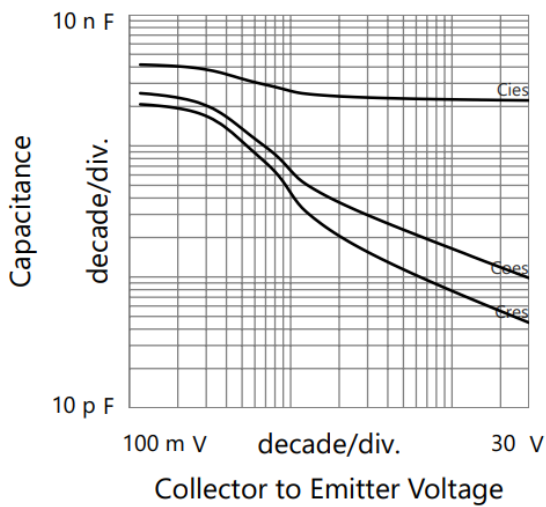

Gate Charge

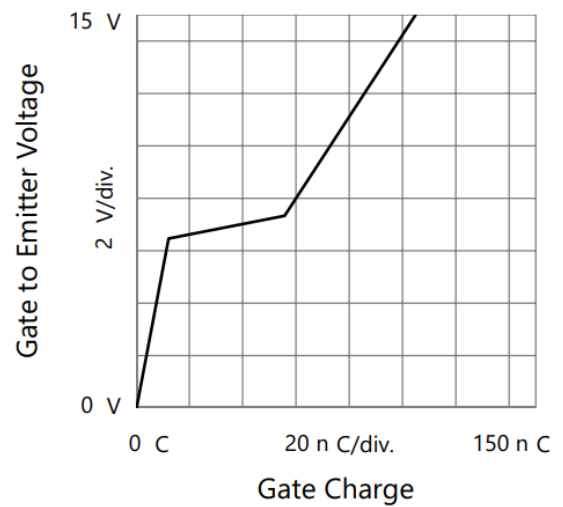

封装信息:

TO-247 封装尺寸图

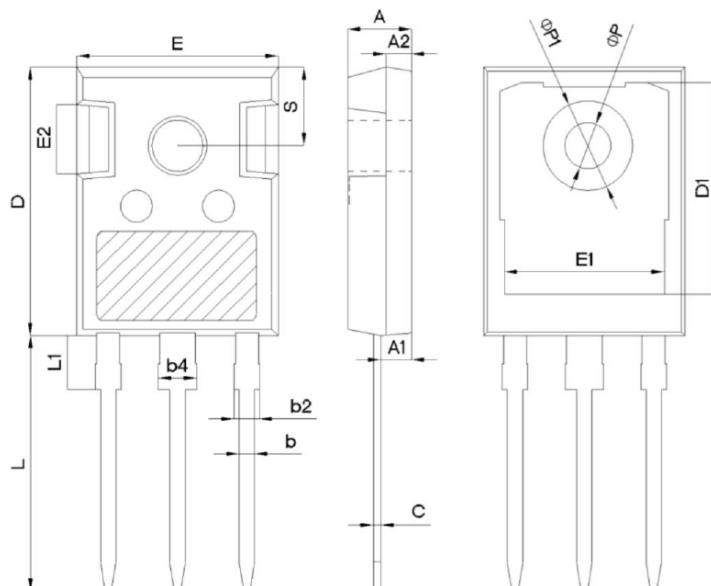

SYMBOL	mm		
	MIN	NOM	MAX
A	4.80	5.00	5.20
A1	2.21	2.41	2.61
A2	1.85	2.00	2.15
b	1.11	1.21	1.36
b2	1.91	2.01	2.21
b4	2.91	3.01	3.21
c	0.51	0.61	0.75
D	20.70	21.00	21.30
D1	16.25	16.55	16.85
E	15.50	15.80	16.10
E1	13.00	13.30	13.60
E2	4.80	5.00	5.20
E3	2.30	2.50	2.70
e	5.44BSC		
L	19.62	19.92	20.22
L1	-	-	4.30
ΦP	3.40	3.60	3.80
ΦP1	-	-	7.30
S	6.15BSC		

TO-220F 封装尺寸图:

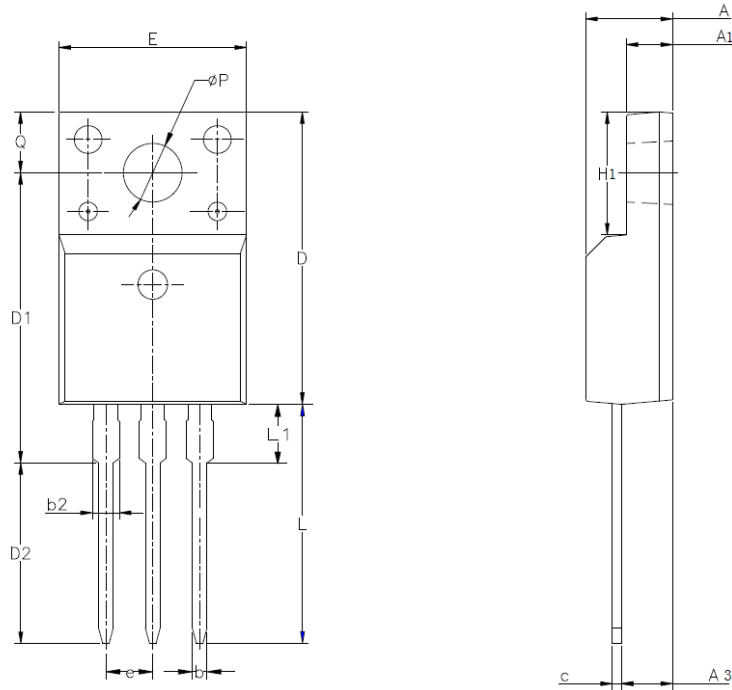

SYMBOL	MIN	NOM	MAX
A	4.42	4.70	5.02
A1	2.30	2.54	2.80
A3	2.50	2.76	3.10
b	0.70	0.80	0.90
b2	—	—	1.47
c	0.35	0.50	0.65
D	15.25	15.87	16.25
D1	15.30	15.75	16.30
D2	9.30	9.80	10.30
E	9.73	10.16	10.36
e	2.54BCS		
H1	6.40	6.68	7.00
L	12.48	12.98	13.48
L1	/	/	3.50
øP	3.00	3.18	3.40
Q	3.05	3.30	3.55

TO-220 封装尺寸图:

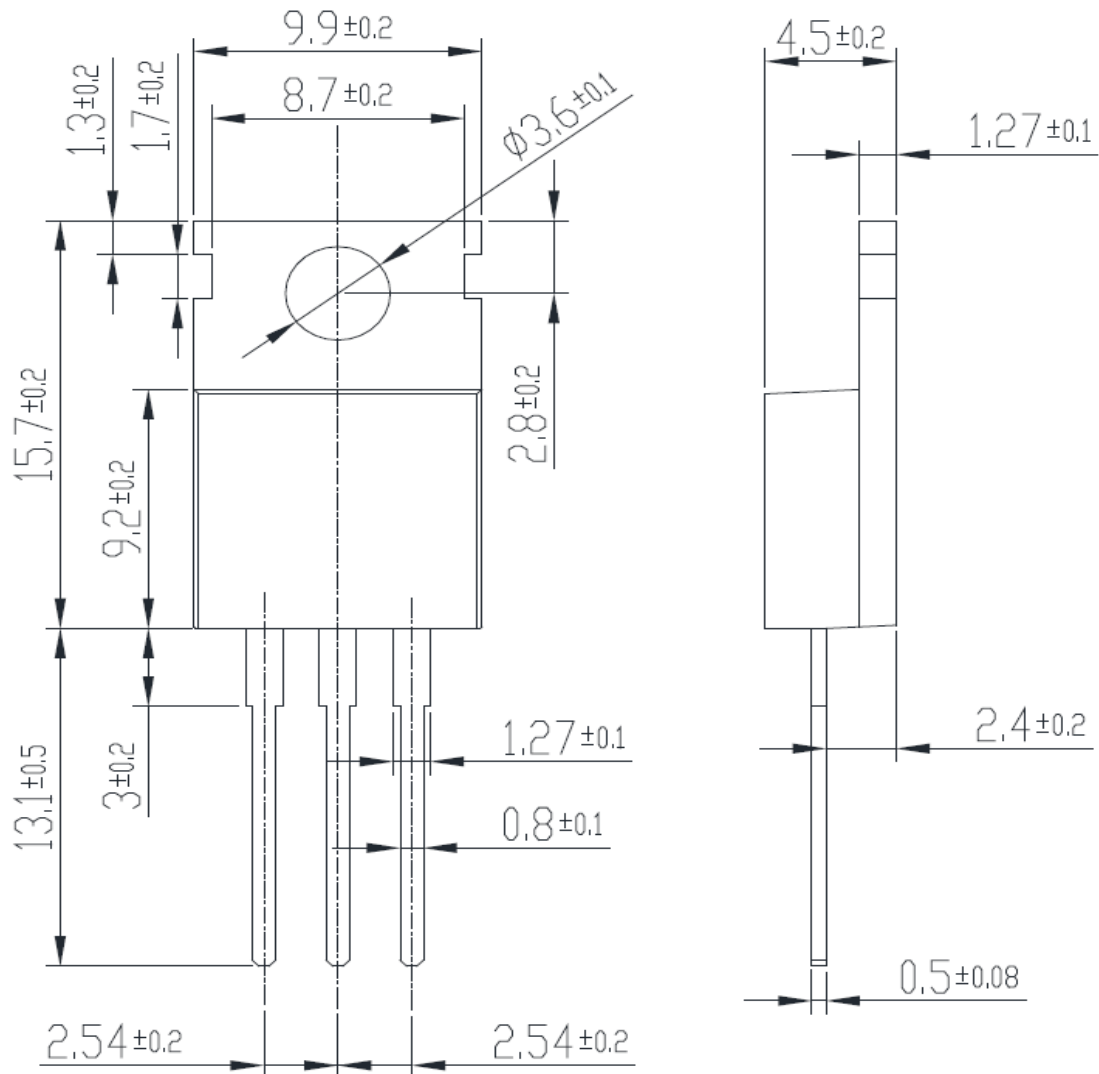

TO-263 封装尺寸图:

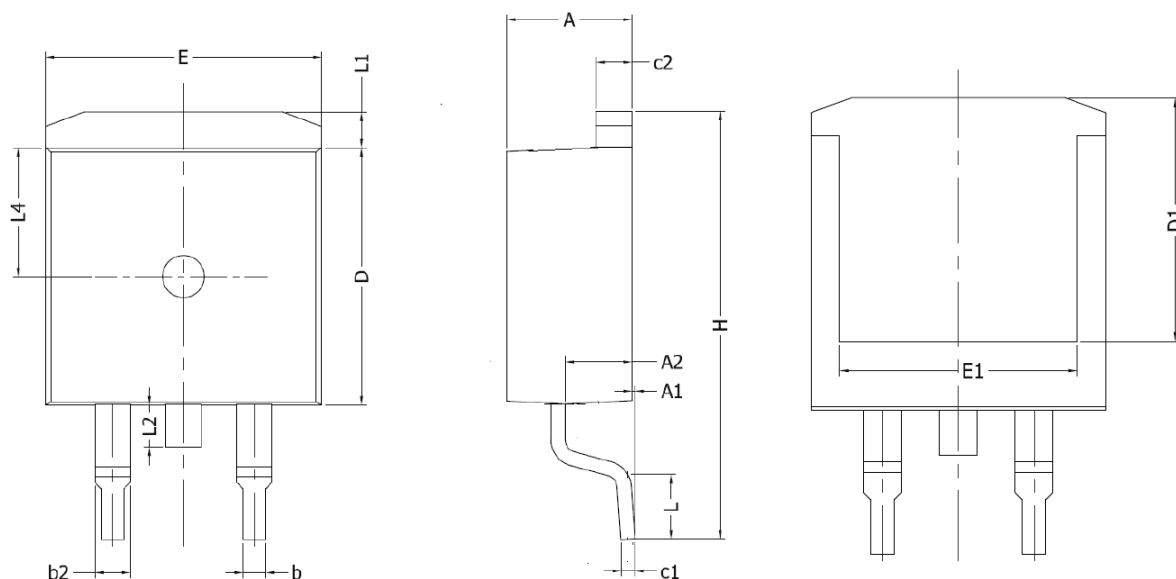

Symbol	Dimensions In Millimeters		Dimensions In Inches	
	Min.	Max.	Min.	Max.
A	4.40	4.60	0.17	0.18
A1	0.00	0.25	0.00	0.01
A2	2.20	2.60	0.09	0.10
b	0.76	0.89	0.03	0.04
b2	1.23	1.37	0.05	0.05
C	0.47	0.60	0.02	0.02
c1	0.46	0.56	0.02	0.02
c2	1.25	1.35	0.05	0.05
D	0.91	0.93	0.04	0.04
D1	8.00	-	0.31	-
E	9.80	10.00	0.39	0.39
E1	7.80	-	0.31	-
e	2.54BSC		0.10BSC	
H	14.90	15.70	0.59	0.62
L	2.00	2.60	0.08	0.10
L1	1.17	1.40	0.05	0.06
L2	-	1.75	-	0.07
L4	4.60REF		0.18REF	



版本记录

日期	版本	更改内容
2021.09.24	0.0	初稿
2021.12.21	0.1	部分参数更新
2022.01.06	0.2	增加表编号
2022.04.08	0.3	部分参数更新
2022.07.04	0.4	部分参数更新
2023.03.07	0.5	添加新封装