

**Mirsew**  
INDUSTRIAL SEWING MACHINE

## 宁波美之缝机械有限公司

NINGBO MIRSEW MACHINERY CO.,LTD.

Add:8-4,NO.523 AND 525,YANGFAN ROAD,NINGBO  
HIGH TECH ZONE,ZHEJIANG

Website:www.mirsew.com

E-mail:admin@mirsew.com

TEL:+86 18058598290



注：本画册所列产品可能会因改良而有所变动，以随机说明书为标准，恕不另行通知。由于印刷原因，与产品实际颜色可能稍有差异，敬请谅解。

NOTE: The products listed in this brochure may be subject to change due to improvements, an the accompanying instructions are the standard without prior notice. Due to prining reasons, the actual color of the product may be slightly different, please understand.

CREATING MIRACLES  
SEWING LIFE



Mirsew

ONLY TO **SATISFY GLOBAL**  
CUSTOMERS AND PROVIDE  
**BETTER QUALITY**

只为满意全球客户，只为提供更优品质

[www.mirsew.com](http://www.mirsew.com)





宁波美之缝机械有限公司位于中国浙江省宁波市，是一家为集产品研发、设计、试制、生产、检测、销售以及售后服务为一体的现代化企业。

公司专业生产各种缝纫机。产品主要应用于服装制造、皮革工业、帆布、室内装饰、汽车、制鞋、箱包工业等领域。产品远销欧美、中东、东南亚等100多个国家和地区。公司在行业内较早的通过了ISO9001：2008质量管理体系，产品实施全球化的营销策略，并以其信服的质量和优良的服务赢得了消费者的信赖。

一直以来，公司始终坚持“永不满足，实现理想”的主题理念，致力于创造缝纫机经典。

**我们的宗旨：“精心打造完美品质”；**

**我们的发展目标：“一丝不苟、精益求精，不断满足客户需求”；**

**我们的精神：“奋斗不息”；**

随着中国服务行业快速向国际化接轨，我们充分发挥MIRSEW人勤于思考、善于创新的特长，发挥自身优势，携手客户共同探索未来，携手共创辉煌。

NINGBO MIRSEW MACHINERY CO.LTD. is located in Ningbo, Zhejiang Province, China. It is a modern enterprise that integrates product research and development, design, trial production, production, testing, sales, and after-sales service.

The company specializes in producing various sewing machines.

The product is mainly used in the fields of clothing manufacturing, leather industry, canvas, interior decoration, automobiles, shoemaking, luggage industry, etc. Our products are exported to over 100 countries and regions including Europe, America, the Middle East, and Southeast Asia. The company has passed the ISO9001:2008 quality management system earlier in the industry, and implements a global marketing strategy for its products, And it has won the trust of consumers with its convincing quality and excellent service. Throughout, the company has always adhered to the theme of "never satisfied, realizing ideals" and is committed to creating classic sewing machines.

Our aim is to "meticulously create perfect quality";

Our development goal is to be meticulous, strive for excellence, and continuously meet customer needs;

Our spirit: "Striving endlessly";

With the rapid internationalization of China's service industry, we fully leverage the strengths of MIRSEW people who are diligent in thinking and good at innovation, leverage our own advantages, and work together with customers to explore the future and create brilliance.





























































# COMPANY PROFILE



产品远销于欧美，东南亚等 **60+** 个新兴国家

Products are exported to more than 60 countries such as Europe and America and Southeast Asia.

# SYMBOLS

					
Flat bed	No. of threads	Top and bottom feed	Light-weight material	Roller presser foot	Width of edge cutting
					
Flat bed	Style	Unison feed	Medium-weight material	Straight line bartacking	Thickness of cloth cutting
					
Box type	Needle	On the differential travel	Heavy-weight material	Thread wiper	Mode of adjustment in sewing space
					
Post bed	Needle gauge	No. of needles	Thin thread	Thread trimmer	Button type adjustment
					
Cylinder type	Stainless steel	Sewing speed	Medium thread	Button diameter	Needle gauge
					
Cutter scissors	Function	Sewing speed (with controller)	Heavy thread	Attaching form	Amplitude of needle fluctuation
					
Horizontal hook (standard)	Stitch length	Lift of the presser foot	Special heavy thread	Reverse stitching	Diagram conversion
					
Horizontal hook (large)	Stitch length	Main feed amount	Extra heavy-weight material	Alternation range	Bar-tacking length
					
Vertical hook (standard)	Stitch width	Differential ratio	Motor	Looper	Bar-tacking width
					
Vertical hook (large)	Bottom feed	Differential feed amount	Split needle bar	Catcher	Twin needle gauge
					
Shuttle hook	Differential feed	Differential ratio	Needle stroke	Sewing mode	Packing
					
Electronic thread tension	Needle feed	Cutter	Wheel feed	Cloth blade	Net/gross weight

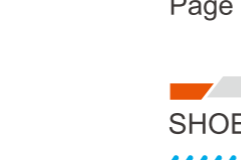
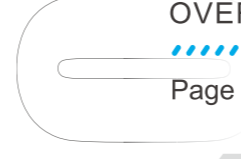
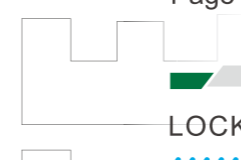
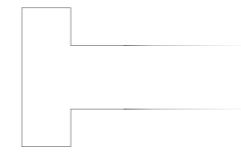

## AUTOMATIC SERIES

自动化系列

Page 01—18

## LOCKSTITCH MACHINE SERIES

平缝机系列

Page 19—29

## HEAVY-DUTY WALKING FOOT SERIES

厚料系列

Page 30—39

## OVERLOCK MACHINE SERIES

包缝机系列

Page 40—46

## INTERLOCK MACHINE SERIES

绷缝机系列

Page 47—54

## ZIGZAG MACHINE SERIES

曲折缝系列

Page 55—61

## SPECIAL SEWING MACHINE SERIES

特种机系列

Page 62—76

## SHOES AND BAGS MACHINE SERIES

鞋机箱包系列

Page 77—88

## MULTI-NEEDLE MACHINE SERIES

多针机系列

Page 89—94

## EMBROIDERY MACHINE SERIES

绣花机系列

Page 95—100

## BLIND STITCH/FLAT SEAMING MACHINE SERIES

暗缝/麦夹机系列

Page 101—103

## CUTTING MACHINE SERIES

裁剪机系列

Page 104—113

## BELT CUTTING MACHINE SERIES

切带机系列

Page 114—119

## HOUSEHOLD SEWING MACHINE SERIES

家用缝纫机系列

Page 120—125

## IRONING MACHINE SERIES

整烫系列

Page 126—141

## OTHER EQUIPMENT MACHINE SERIES

其他设备系列

Page 142—154

# CATALOGUE JEANS

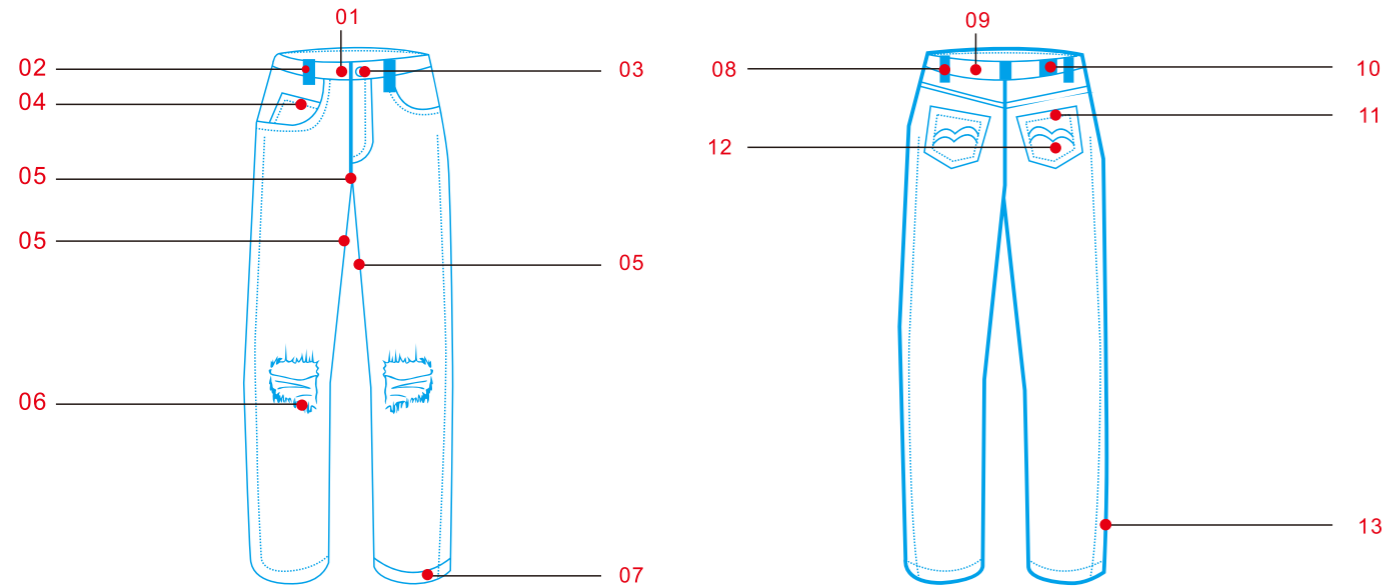

**01**  
**MS-9820**  
Electronic Eyelet Button  
Holing Sewing Machine



**02**  
**MS-254**  
Automatic 2 Needle Belt-Loop  
Attaching Machine



**03**  
**MS-K988A**  
Automatic(Snap Fastener)  
Rivet Machine



**04**  
**MS-8750A/8450A**  
Double Stepping Motor Double  
Needle Computerized Lockstitch  
(Large Hook/Small Hook)



**05**  
**MS-9688XH-PF/CT-T-H9**  
Automatic High Speed  
Multifunctional Feed-off-the-arm  
Chainstitch Machine



**06**  
**MS-B342/B326/B311**  
Single Needle Electronic  
Pattern Machine



**07**  
**MS-68900**  
Automatic Leg Bottom  
Hemming Machine



**08**  
**MS-2000C**  
Multi-needle Machine For  
Belt Loop Making



**09**  
**MS-1104PTC**  
Waitband Sewing Machine



**10**  
**MS-B342/B326/B311**  
Single Needle Electronic  
Pattern Machine



**11**  
**MS-MH380MH**  
Automatic Pocket  
Hemming Machine



**12**  
**MS-BAS311TD**  
Automatic Pocket  
Setter Machine



**13**  
**MS-GT90BN**  
Automatic Overlock  
Sewing Machine  
With Stepping Motor

# CATALOGUE SHIRT

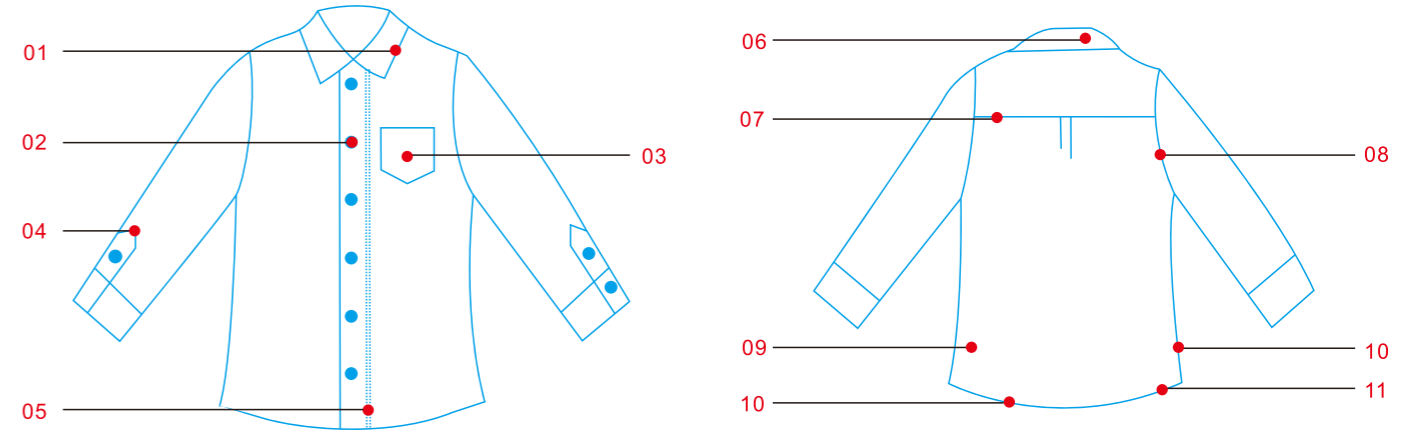

**01**  
**MS-9982X-D4-DB**  
High Speed Needle Feed Lockstitch  
With Edge Cutter



**02**  
**MS-1790A**  
Electronic Straight Button  
Holing Sewing Machine



**02**  
**MS-988-LK1903**  
Automatic Button Feeder With Electronic  
Button Attach Machine (Rotary Cylinder)



**03**  
**MS-7300ATD**  
Automatic Shirt Pocket  
Setter Machine



**04**  
**MS-XC01**  
Automatic Sleeve Placket  
Setter Machine



**05**  
**MS-8750A/8450A**  
Double Stepping Motor Double  
Needle Computerized Lockstitch  
(Large Hook/Small Hook)



**06**  
**MS-450MS**  
Auto-Belt Adjustment Fusing  
Machine (Seamless Belt)



**07**  
**MS-5490A-D4**  
Stepping Motor Upper Differential  
Computerized Lockstitch



**08**  
**MS-A8F-C**  
Single Stepping Motor Computerized  
Lockstitch  
(Double Knife & Seal Oil Pan)



**09**  
**MS-GT90BN**  
Automatic Overlock  
Sewing Machine  
With Stepping Motor



**10**  
**MS-927-D**  
Direct Drive 2 Needle  
Feed-off-the-arm  
Chainstitch Machine



**11**  
**MS-5490A-D4**  
Stepping Motor Upper Differential  
Computerized Lockstitch

# CATALOGUE T-SHIRT

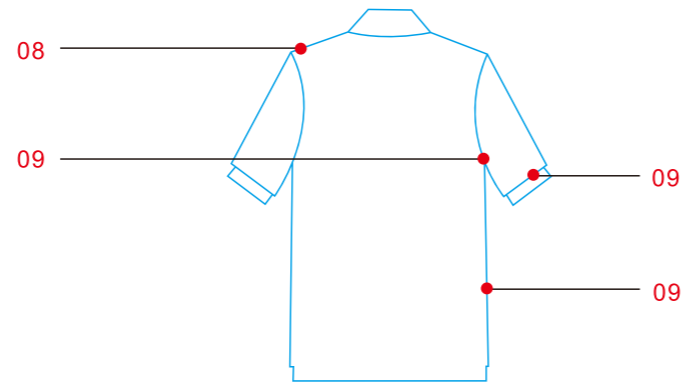
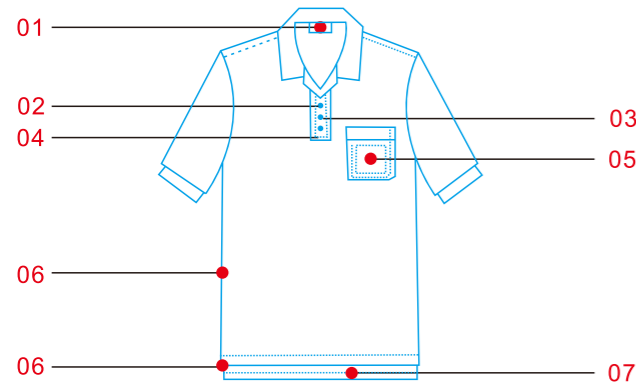

**01**  
**MS-A8F-C**  
Single Stepping Motor Computerized Lockstitch (Double Knife & Seal Oil Pan)



**02**  
**MS-MJ02**  
Automatic Placket Setting Machine



**03**  
**MS-988-LK1903**  
Automatic Button Feeder With Electronic Button Attach Machine (Rotary Cylinder)



**04**  
**MS-1790A**  
Electronic Straight Button Holing Sewing Machine



**04**  
**MS-430DPE**  
Electronic High Speed Bartacking Machine For Belt Loop



**05**  
**MS-7300ATD**  
Automatic Shirt Pocket Setter Machine



**06**  
**MS-GR90ND**  
Automatic Overlock Sewing Machine With Stepping Motor



**07**  
**MS-G1278**  
Automatic Coverstitch Bottom Hemmer



**08**  
**MS-9982-D4**  
Needle Feed Computerized Lockstitch



**09**  
**MS-GT90BN**  
Automatic Overlock Sewing Machine With Stepping Motor

# CATALOGUE SUITS

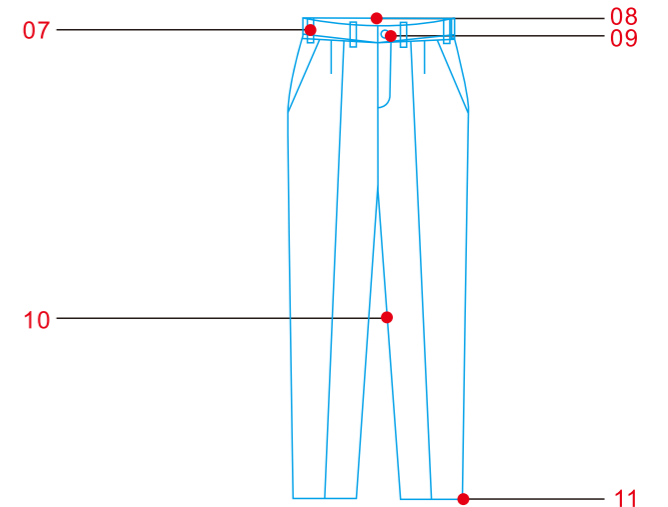
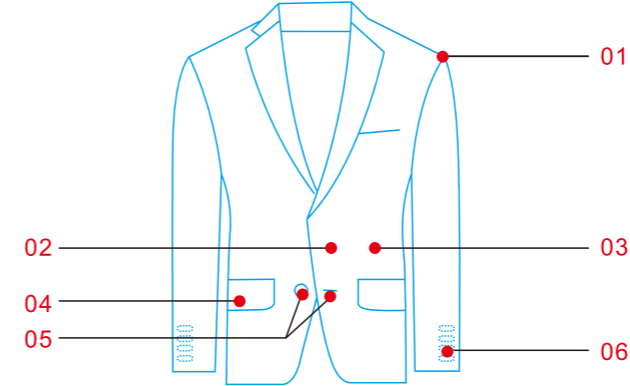

**01**  
**MS-560A**  
Computerized Sleeves Setting Machine(Double Motor)



**02**  
**MS-781Z**  
Computerized Head Stitch Sewing Machine



**03**  
**MS-357BD**  
Trousers Waist Blind Stitch Sewing Machine With Back-located Drive Motor



**04**  
**MS-895KD**  
Automatic Pocket Welting Machine



**05**  
**MS-9820**  
Electronic Eyelet Button Holing Sewing Machine



**05**  
**MS-988-LK1903**  
Automatic Button Feeder With Electronic Button Attach Machine (Rotary Cylinder)



**06**  
**MS-6200F**  
Computerized Imitation Buttonhole Sewing Machine(Angle Range 0-30)



**07**  
**MS-370BD**  
Trousers Ears Blind Stitch Sewing Machine With Back-located Drive Motor(Width-adjusted)



**08**  
**MS-9407A**  
Automatic Sewing Machine For Darts And Waistband Pleats



**09**  
**MS-289**  
Computer Controlled, High Speed, Single-thread Chainstitch, Button-Neck-Wrapping Machine



**10**  
**MS-GT90BN**  
Automatic Overlock Sewing Machine With Stepping Motor



**11**  
**MS-68900**  
Automatic Leg Bottom Hemming Machine

# CATALOGUE SPORTS WEARS

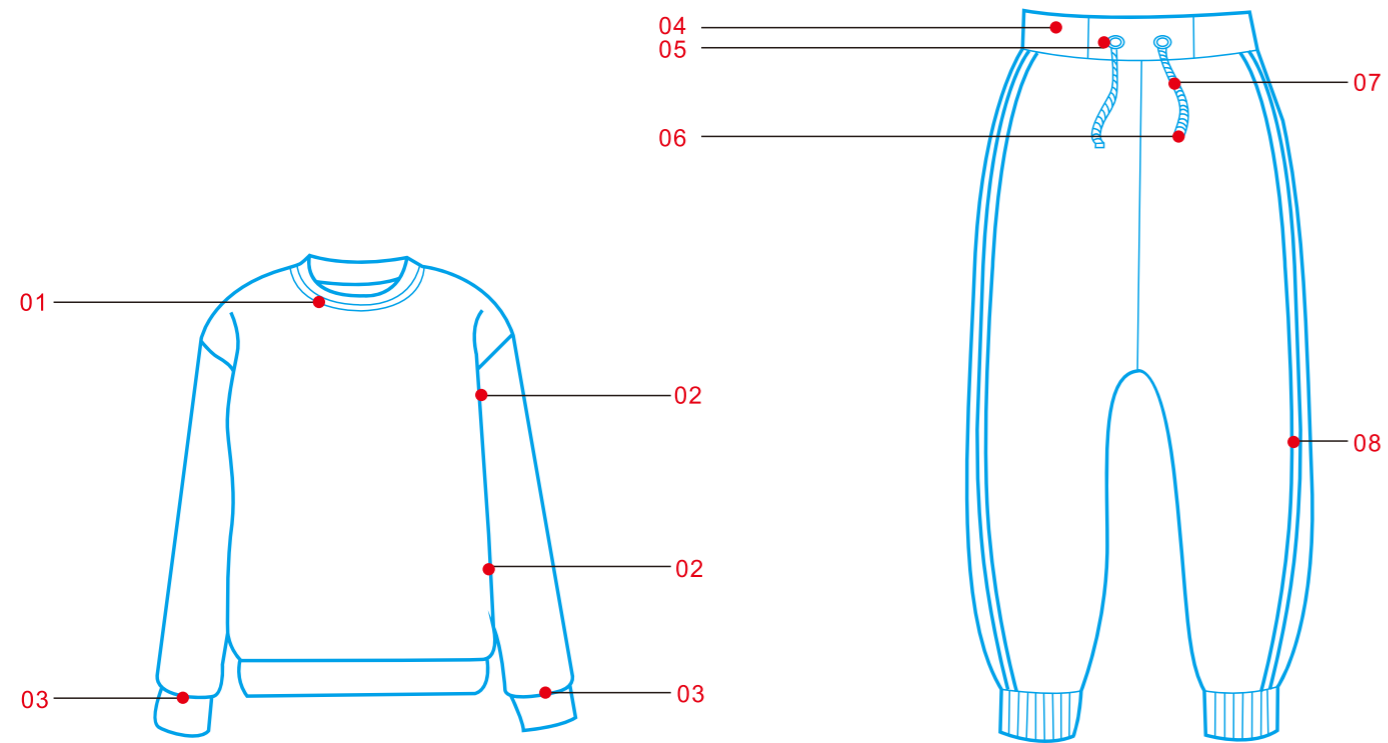

**01**  
**MS-GL99BT-K2**  
Automatic Cylinder Bed Collar Feeding Overlock Sewing Machine With Upper Differential

**02**  
**MS-GT90BN**  
Automatic Overlock Sewing Machine With Stepping Motor

**03**  
**MS-AC1501**  
Automatic Rib Cuff Sewing Machine

**04**  
**MS-008-12064P-DD**  
12 Needle, Cylinder Bed, Double Chainstitch Machine



**05**  
**MS-430DMO**  
Electronic Punching And Bartacking Sewing Machine

**06**  
**MS-CS380**  
Automatic String Thrusting Machine

**07**  
**MS-B342/B326/B311**  
Single Needle Electronic Pattern Machine

**08**  
**MS-1212PLB-TK-UFSL**  
12 Needle, Flatbed, Looper Longitudinal Double Chainstitch Sewing Machine (With Upper Tape Feeder Device)

# CATALOGUE BOXES AND BAGS

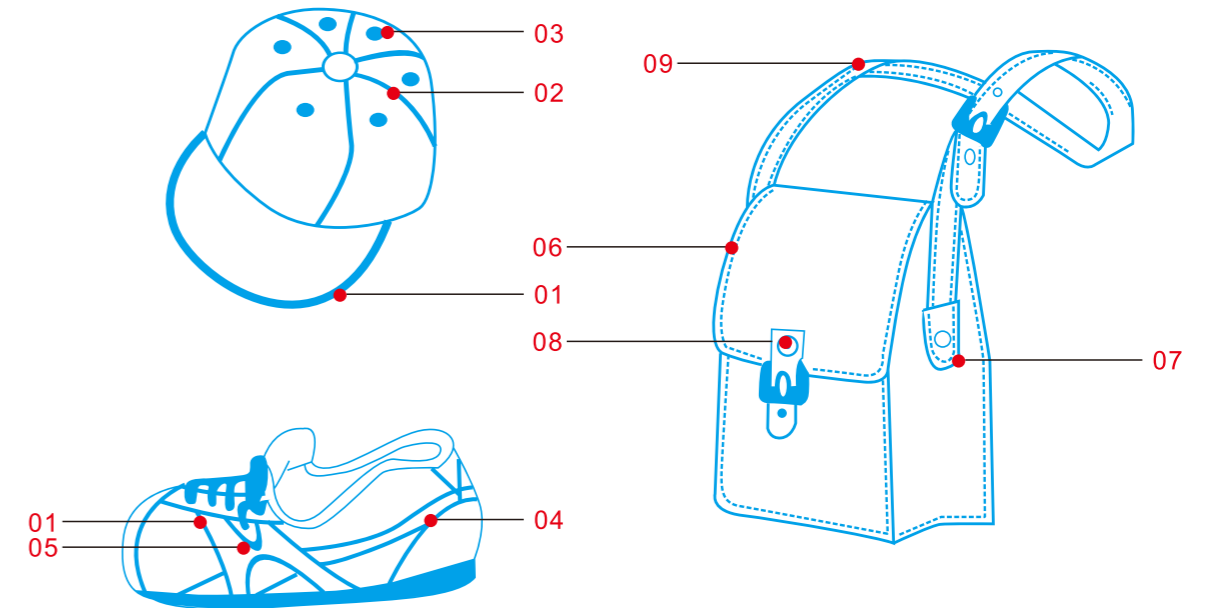

**01**  
**MS-B342/B326/B311**  
Single Needle Electronic Pattern Machine

**02**  
**MS-8752D/8452D/8722D/8422D**  
Integrated Double Needle Direct Drive Lockstitch

**03**  
**MS-430DMO**  
Electronic Punching And Bartacking Sewing Machine

**04**  
**MS-591/592**  
Single/Double Needle Computerized Post Bed Compound Feed Roller Machine



**05**  
**MS-1530-7C**  
Single Needle Computerized Zigzag Sewing Machine (Large Hook)

**06**  
**MS-M7**  
Double Stepping Motor Computerized Top And Bottom Feed Lockstitch

**07**  
**MS-8365-D2**  
Direct Drive Single Needle Compound Feed Post Bed Machine

**08**  
**MS-1900D**  
Computer Controlled High Speed Bartacking Machine

**09**  
**MS-246**  
Single Needle Cylinder Bed Compound Feed Lockstitch Sewing Machine

Automatic Series  
自动化系列

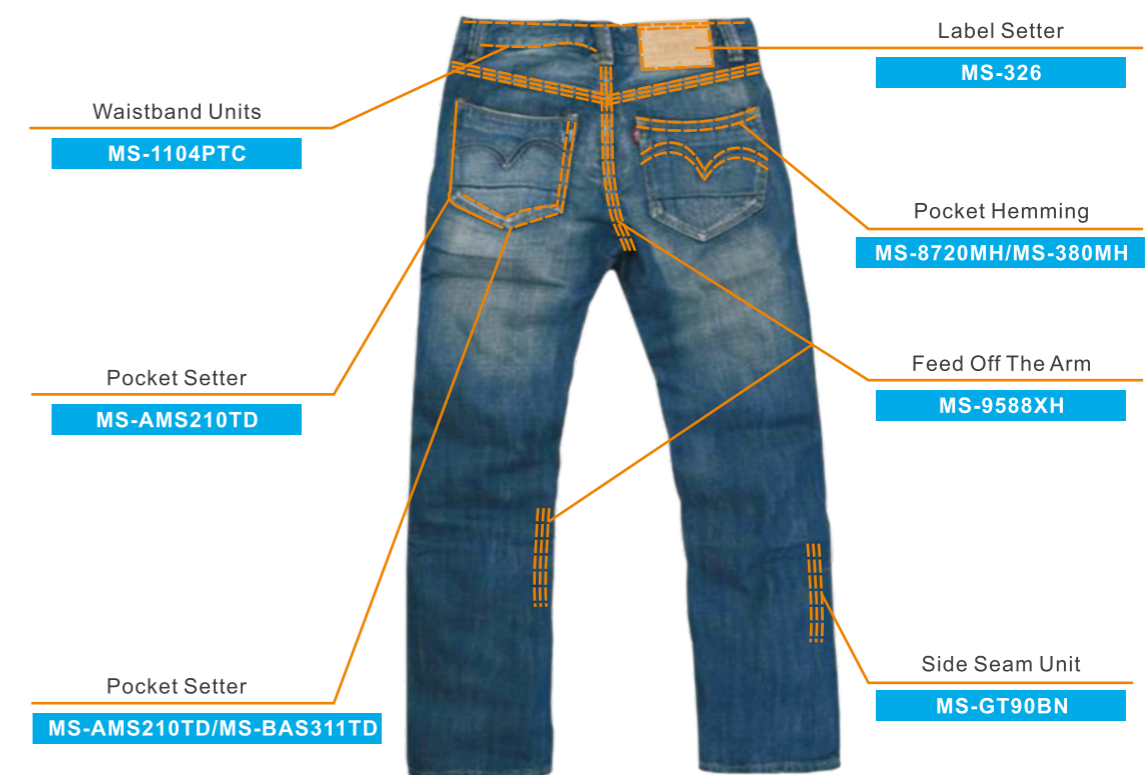

NEW!



**MS-AMS210TD**  
全自动贴袋机  
Automatic Pocket Setter Machine



**MS-BAS311TD**  
全自动贴袋机  
Automatic Pocket Setter Machine



**MS-MH380MH**  
全自动链式卷口袋机  
Automatic Pocket Hemming Machine



**MS-8720MH**  
全自动双针卷口袋机  
Automatic Pocket Hemming Machine



**MS-7300A-COIN**  
硬币口袋贴袋机  
Coin Pocket Setter Machine



**MS-254**  
全自动双针裤襻机  
Automatic 2 Needle Belt-Loop Attaching Machine

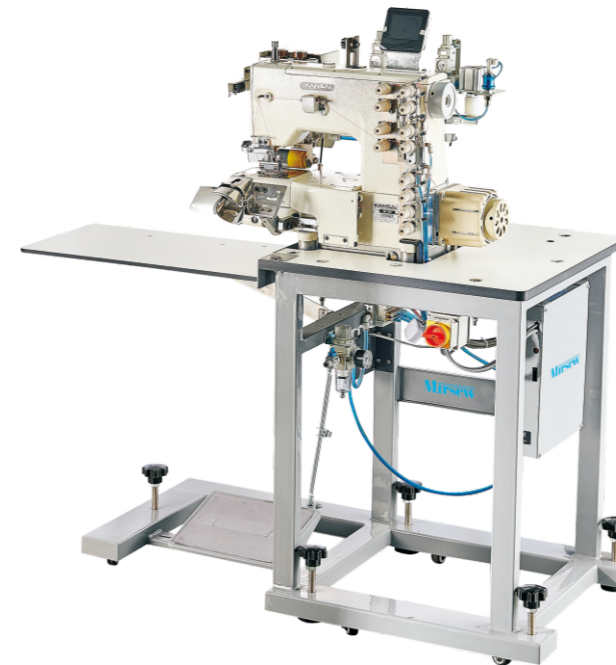

**MS-1104PTC**  
链式上腰机  
Waistband Sewing Machine



**MS-68900**  
全自动裤脚机  
Automatic Leg Bottom Hemming Machine



**MS-9588**  
高速多功能曲腕机系列  
High Speed Multifunctional Feed-off-the-arm  
Chainstitch Machine



**MS-9688XH-PF/CT-T-H9**  
高速全功能自动曲腕机  
Automatic High Speed Multifunctional  
Feed-off-the-arm Chainstitch Machine



**MS-7300ATD**  
全自动衬衫口袋贴袋机  
Automatic Shirt Pocket Setter Machine



**MS-XC01**  
自动衬衫袖衩机  
Automatic Sleeve Placket  
Setter Machine

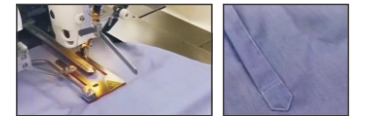

**MS-9588-ECV-T-DD**  
高速多功能曲腕机系列  
High Speed Multifunctional Feed-off-the-arm  
Chainstitch Machine



**MS-9578-TL**  
直驱高速双针领条机  
Double Needle Multifunctional Direct Drive  
Feed-off-the-arm Chainstitch Machine



**MS-6003A-LBH1790S**  
全自动连续锁眼机  
Automatic Shirt Buttonhole Indexer



**MS-9020A**  
熨烫袖衩机  
Sleeve Placket Creaser

Model	Needle	Stitch	Stitch Length	Stitch Width	Speed (S.p.m)	Power (W)
MS-9588	TVX64, TVX5 #18, TVX5 #21	1/4, 3/16, 7/32, 1/8	2.6-4.8mm	3800	750	
MS-9688XH-PF/CT-T-H9	TVX5 #21	3	1/4, 3/16, 7/32, 1/8	5000		
MS-9588-ECV-T-DD	TVX5 #21, TVX64#14	2/3	1/4, 3/16, 7/32, 1/8	4300		
MS-9578-TL	TVX64#14	2	1/4, 3/16, 7/32, 1/8	4300		

**MS-G1278**

全自动折缝下摆机  
Automatic Coverstitch Bottom Hemmer



1. With high sewing speed, which is 4000 rpm;
2. And one machine can produce 180-240 pieces per hour;
3. One worker can operate two machines simultaneously, which improves the production efficiency and saves labor costs;
4. This production quality qualification rate of this machine is about 97% and the product downtime rate of about 1%.



**MS-BAF**

自动折袖口&下摆缝切装置  
Auto Folding Cuff&hem Sewing Device



Automatic folding cuff & hem sewing device: automatic control, that novices can use as simple operation, uniform high quality and efficiency several times.



M3:DD servo motor controller box P



TD20:Auto thread trimmer device (Optional)

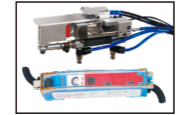

BAF:Auto folding cuff & hem sewing device Correlation sensor



P:Foot lifter F:Air reaulator (Filter)

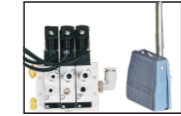

S3:Solenoid valves Knee Switch

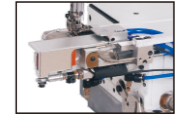

MINI-BAF:For super finehead coverstitch M/C Auto folding cuff & hem sewing device (Optional)



**MS-G201**

自动折缝(片式)下摆机  
Automatic Folding (Plane Type)  
Hem Sewing Machine



Product introduction:

1. Suitable for T-shirt single-piece automatic folding and swinging sewing;
2. Synchronized sewing of patented vice-hangers;
3. Operation of the first undercut sewing process;
4. Automatic folding pendulum device to control folding distance;
5. The starting and ending stitches are exactly the same;
6. Automatic Induction Blowing Auxiliary Device;
7. Visual Intelligent Operating Panel Control.

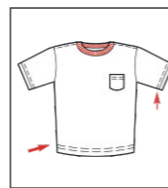

Power	AC220V
Rotation speed	3600-5000RPM
Capacity	400PCS/hour

**MS-SAF**

自动折缝(片式)下摆&堆栈机  
Automatic Folding (Plane Type) Hem Sewing & Stack Machine



1. Hemming flat garments of T-shirts, polo shirts and similar garments;
2. This machine is economic and does not need much operation skills, realizing the folding sewing work that needed complex automatic equipment. This machine simplifies the complicated sewing process, smarter, easier to operate;
3. The operator simply places the fabric. Then the sewing unit automatically performs the hemming operations, providing uniform and quality products. The operator then prepares the next fabric in sequence, and production is greatly increased;
4. The sewing unit is equipped with a variable top feed, and the top feed can help feed the fabrics stably, so the twist in hemming operations can be avoided;
5. Hemming width:20-30mm.



High sensitive photoelectric equipment



Rear puller device

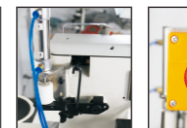

Automatic presser foot lifting device



Emergency start/stop button

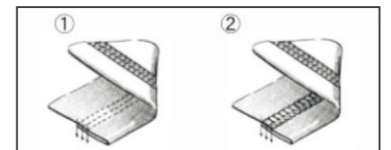

**MS-G1601**

自动T恤上圆领包缝机  
Automatic T-shirt Neck Joining Machine



**Advantages:**  
Circular rib elastic band for sewing T-shirt round neck and waistband. Sewing t-shirts, belts and other woven products of the circular rib elastic belt, as long as the collar set in the sewing machine on the guide rail, adjust the front and rear tightness and the corresponding width, just focus on the control of body seam material can be ribbed width sewing uniform, improve the efficiency of collar and product quality.

Air pressure	0.6MPa
Rotation speed	4500RPM
L*W*H	1.38*0.78*1.36m
Sewn collar width	1-4CM
Sewn collar size	20-100CM
Collar tightness	2-9CM
Accuracy rating	±2mm
Waistband size	35-140CM
Capacity	145PCS/ hour

**MS-AC1501**

自动上罗纹袖口机  
Automatic Rib Cuff Sewing Machine



**Advantages:**  
1. Equipped with a puller to keep the fabric stable during operation;  
2. Electronic control system automatically adjusts size, pneumatic/ electric automatic size control;  
3. Equipped with automatic material collecting device, automatic expansion device, automatic thread trimming, etc;  
4. Suitable for sewing the cuffs of sweatshirts, sports pants, etc.



**MS-MJ02**

电脑门襟缝纫机  
Automatic Placket Setting Machine



1. Intelligent control improves production efficiency and is easy to operate, workers can learn simple operations in 20 minutes;  
2. Apply famous brand elements;  
3. Independent cutter device: apply dual shaft structure, assure stable movement and less wearing for cutter;  
4. Intelligent touch screen: Micro computer control, there are 2 standard modes: single / bilateral placket solution;  
5. The slotless moving needle plate ensures smooth movement of the fabric during sewing and keeps the fabric flat.

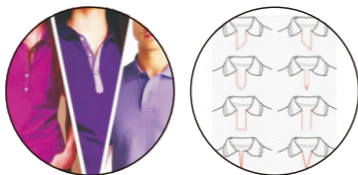

Model	MS-MJ02
Air Pressure	0.5-0.6Mpa
Needle	DBX1(10#,11#,12#)
Sewing Precision	±0.02mm
Sewing Needle Pitch	1.00-5.00mm
Sewing Speed	400-4000rpm
Sewing Width	1.00-50.00mm
Sewing Length	1.00-320.00mm
Packing Dimensions	1680Lx950Wx1450H mm
Gross Weight	373kg

**MS-G997**

高速自动翻切螺纹袖口机  
Automatic Rib Cuff Sewing Machine



Applicable to thread sewing of various cuffs and cuffs

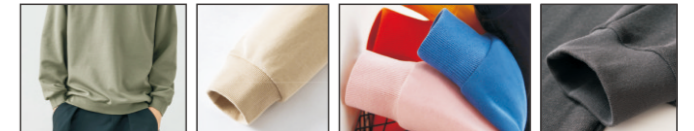

This equipment can be used to flip and cut various rib cuff, and the maximum speed is about 60pcs per minute.

1. It can be matched with various brands sewing machine;
2. Self-compiled control program can change various cutting methods according to customer requirements;
3. Multi-group memory storage, quick and convenient for switching and calling at any time;
4. The ingenious and coherent mechanical structure design makes the turn-over and material collection complete at one time, thus achieving high efficiency.

Flipping half size	4-12.5cm
Flipping width	4-11cm
Efficiency(minutes)	60
Voltage	AC110/220v
Air pressure	>0.8kpa

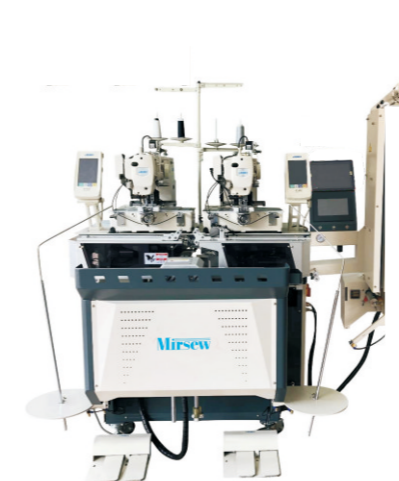

**MS-103E**

接橡筋机  
Automatic Elastic Band Joiner



**MS-102E**

全自动接橡筋机(超声波切料)  
Automatic Elastic Band Joiner



**MS-101E**

全自动双条接橡筋机(冷刀切料)  
Automatic Elastic Band Joiner



**MS-785Z**  
电脑珠边机  
Computerized Hand Stitch Sewing Machine



**MS-781Z**  
电脑珠边机  
Computerized Hand Stitch Sewing Machine



**MS-560A**  
高级电脑上袖机(双电机)  
Computerized Sleeve Setting Machine  
(Double Motor)



**MS-550A**  
高级电脑上袖机(单电机)  
Computerized Sleeve Setting Machine  
(Single Motor)



**MS-160/21**  
单线电子控制暗缝套结机(6/8/12针)  
Single Thread Spot Tacking Blindstitch Machine  
(6/ 8/12 needle)



**MS-160/32**  
单线电子控制暗缝套结机(随意调节针数)  
Single Thread Spot Tacking Blindstitch Machine  
(Arbitrarily Adjust The Number Of Stitches)



**MS-6200F**  
电脑假眼机(斜角范围0-30度)  
Computerized Imitation Buttonhole  
Sewing Machine(Angle Range 0-30)



**MS-333B**  
单针筒式复衬机  
Single Needle Cylinder Bed Sewing Machine For Tacking & Basting



**MS-9407A**  
自动西裤省位机  
Automatic Sewing Machine For Darts And  
Waistband Pleats

**MS-9207A**  
自动切刀运模机  
Small Automatic Template Machine With Cutter



**MS-697**  
单针锁缝上垫肩机  
Single Needle Lockstitch Post-Bed Machine  
For Finishing Armholes



**MS-895KD/896KD**  
开袋机  
Automatic Pocket Welting Machine

**MS-KD08**  
全自动激光开袋机  
Automatic Laser Pocket Welting Machine



1. Multi-process bag opening can be completed at once, avoid complicated manual operations;
2. XY axis adopts high-end servo motor drive, with more accurate and fast response ability, and can greatly extend the service life;
3. Automatic non-iron bag folding mechanism, the pocket folding edge no longer need to re-ironing, improve efficiency and save labor;
4. Automatic shrinkage mechanism of inner pressure frame, increase the replacement adjustment function, the pocket edge stitch change is no longer limited;
5. Input XY coordinates to automatically generate round, square, three-sided rows, shaped pocket graphics, the fastest 3 minutes to complete.

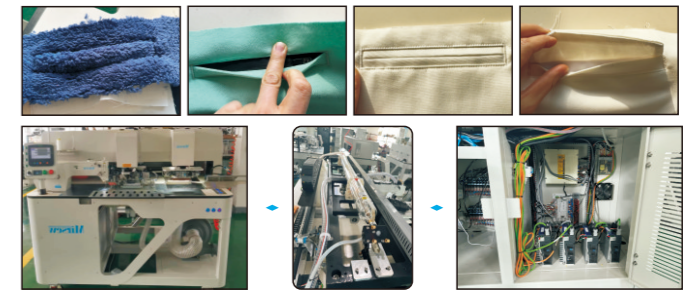

100W laser head Taiwan Delta servo motor drive

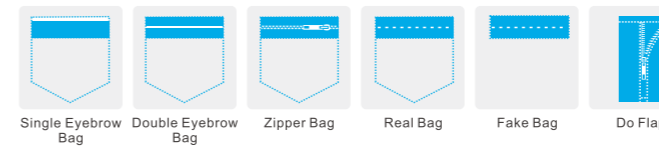

Head Sewing Speed	2500sti/min
Equipped With Handpiece	Brother 311[HS]
Machine Needle	MT*190[12#, 14#, 16#]
Stitch Distance	1.0mm-3.5mm
Pressure Foot Rising Heigt	60mm-80mm
Power	AC220V
Air Pressure And Air Pressure Consumption	0.5Mpa[ 5kg/cm], 22dm/min
Weight	950KG

**MS-201AS/201ZS**  
自动烫袋机  
Automatic Pocket Creasing Ironing Machine



1. Single/Double station operation;
2. Automatic folding function;
3. The electricity can be saved by 30%;
4. The molds can be quickly changed.

Model	MS-201AS/201ZS
Pressing and ironing width	110-200 mm
Pressing and ironing length	120 -190 mm
Average yield	300~450 Pocket/H
The time to change the die	3min
Voltage	220V Single phase-50/60 Hz
Power	3.8kW
Weight	272Kg
Out line dimension(LXWXH)	1000X725X1260mm
Packing size	1060X780X1480mm

**MS-1390A**

高速模板机  
High Speed Template Machine



**High Efficiency, Energy saving and environmental protection**

1. Dry-head, oil free, without stains on materials;
2. Maximum speed 3300RPM, intelligent and efficient;
3. Intelligent winder for hook winding quantity;
4. Servo-actuator drive performance is more superior, higher precision;
5. New auxiliary presser foot, convenient for height adjustment;
6. Automatic hook-changing;
7. Intelligent medium pressure foot, suit for high and low stitching, down proof, avoid start sewing stitch loose;
8. Intelligent electronic tension devices, the tension of forward and back stitches and the tension of light and heavy material line changes automatically.



X Close loop stepping motor  
Y Direction double screw rod

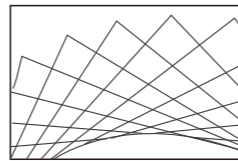

Stitches more beautiful

MS-1390A	DPX5 7-21#	3300	1300X920mm	0.1-12.7mm(0.05)

**MS-1391H-360**

高速厚料智能模板机 (机头360度旋转)  
360° Head Rotation Template Machine



1. The machine head can rotate 360° freely, which can achieve perfect stitches in all sewing areas and ultra-thick materials;
2. X and Y direction screw feeding and synchronous belt feeding to choose;
3. The automatic refueling system of the rotary hook uses a double-capacity hook to reduce the frequency of replacement and improve work efficiency;
4. Presser foot fine-adjustment structure. The height of the presser foot is finely adjusted by the motor;
6. With code scanning function;
7. Standard configuration of upper thread breakage detection device, in case of thread breakage or no bottom thread during sewing.

Model	MS-1391H-360
Sewing Space	1230x910mm
Sewing Speed	2200rpm
Stitch Length	0.5-12.7mm
Working Stroke	21.5mm
Presser Foot Lift	4mm
Needle	DPX17 18-21#
Number of stored patterns	999
Power	800W
Voltage	220V±44
Template Unfolding Size	2490X2179mm
Package Size	1960X1340X1680mm

**MS-1290H-360T**

伸臂旋转式独立驱动花样机 (升降机头)  
Programmable Independent Drives Pattern Machine With Rotary Lifiable Head



1. The machine head can freely rotate 360° and lift up and down, suitable for sewing ultra-thick materials;
2. It adopts a 15-inch wave crystal screen, which can realize WIFI networking. It comes standard with a CF card slot and USB interface;
3. Precision operation control of the machine head and machine tool, rotation angle control unit: 0.05°;
- 4 Presser foot fine adjustment structure, finely adjust the presser foot height through the motor;
5. It has chip scanning and sensing function;
6. Adopt a double-capacity hook and rotary hook automatic refueling system;
- 7 Standard surface thread breakage detection device.

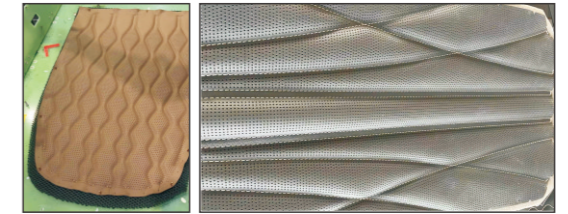
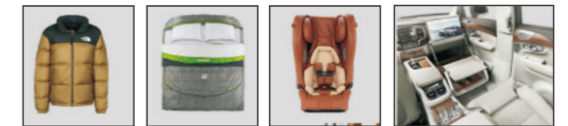

**MS-2225H-360TT**

龙门旋转式独立驱动花样机 (升级机头)  
Independent Drives Rotary And Lifiable Head Quilting Machine



1. The machine head can rotate freely 360° to perfectly sew stitches in any working range. The machine head can be raised and lowered, suitable for sewing ultra-thick materials;
2. Sewing range 2200mm\*2500mm. Can be customized according to customer needs, the maximum sewing range can reach 3200mm\*5000mm;
3. Precise operation control of the machine head and machine tool. Rotation angle control unit: 0.05° Independently driven machine tools and machine heads reduce rotation amount errors;
4. It adopts a 15-inch LCD screen and can realize WIFI networking. It comes standard with a CF card slot and USB interface. By using a U disk or card reader, data can be imported and output from various memories (storage: FD, SM, CF, SD card, etc.);
5. Automatic tool switching device can be equipped according to process requirements;
6. Hook automatic refueling system, using a double-capacity hook to reduce replacement frequency and improve work efficiency;
7. It is equipped with a standard upper thread breakage detection device. If the thread is broken or there is no bottom thread during sewing, the sewing operation can be stopped automatically.

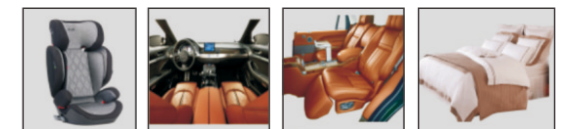

**MS-530A**

全自动小型线上模板机  
Automatic Template Sewing Machine



It can be used for automatic sewing of small and medium-sized sewing process templates of various clothing, easily integrated into the clothing production line. Does not affect the layout of the production line, high efficiency, beautiful stitches no skilled workers.

**Anti-bird nest function:**

Grab type anti-bird's nest structure, sewing wireless head, easy to achieve the bottom line surface line exchange.

**Professional press foot design:**

1. Single-force guide press foot, effectively improve the template flattening effect not easy to misposition, not easy to clamp, compared with ordinary press foot.
2. With the press foot, it can be programmed according to the thickness of the sewing fabric. The height of the press foot changes with the sewing, which makes the pass more stable and the stitch more beautiful.

**MS-530AQ**

全自动小型线上带刀模板机  
Automatic Template Sewing Machine With Blade

- Intelligent
- Energy Saving
- Efficient



- Automatic piece-counting function.
- Automatic thread-broken alarm function.
- Bobbin thread running out alarm function.
- Electronic pressure foot function.
- All functions of the pattern-sewing machine(optional).



Machine head	DDL-8000A(JUKI)
Rated power	1100W220V
Rated vol	220V Single phase 50Hz
Air pressure	0.5Mpa
Needle	DPX17(8#,9#,11#,12#,14#)
Stitch Length	0.5mm-6mm
Presser Foot Lift	0-13mm
Control System	Microcomputer contro
Sewing Speed	1100-3200rpm(MAX)
Number Of Memory Programs	999
Vacuum Motor Power	1.1kw
Machine Weight	221kg
Machine Measurement	133cm(L)X118cm(W)X124cm(H)

Lockstitch Sewing  
Machine Series  
平缝机系列





**MS-5550**  
高速平缝机  
High Speed Lockstitch



**MS-8700**  
高速平缝机  
High Speed Lockstitch



**MS-9100D**  
单直驱高速平缝机  
High Speed Direct Drive Lockstitch



**MS-E50**  
高速电脑平缝机 (触摸屏)  
Computerized Lockstitch (Touch Screen)



**MS-E52**  
高速电脑平缝机 (按键屏)  
Computerized Lockstitch (Button Screen)



**MS-D1**  
单直驱高速平缝机  
High Speed Direct Drive Lockstitch



**MS-V1**  
单直驱高速平缝机  
High Speed Direct Drive Lockstitch



**MS-A1**  
单直驱高速平缝机  
High Speed Direct Drive Lockstitch



**MS-A6**  
高速电脑平缝机  
High Speed Computerized Lockstitch



**MS-8000A**  
高速电脑平缝机  
High Speed Computerized Lockstitch



**MS-D2**  
单剪线高速平缝机  
Direct Drive Lockstitch  
(Only Auto Thread Trimmer)



**MS-A2**  
单剪线高速电脑平缝机  
Direct Drive Lockstitch  
(Only Auto Thread Trimmer)



**MS-A5**  
高速电脑平缝机  
High Speed Computerized Lockstitch



**MS-9000-D4**  
高速电脑平缝机  
High Speed Computerized Lockstitch



**MS-9056/9085-D4**  
长臂电脑平缝机(56/85CM)  
Long-Arm Computerized Lockstitch(56/85cm)

	5000	—	—	—	✓	✓	✓	DBX1 14#(9#-18#)	5.5/13	31/34	590x230x550
MS-5550	5000	—	—	—	✓	✓	✓	DBX1 14#(9#-18#)	5.5/13	31/34	590x230x550
MS-8700	5000	—	—	—	✓	✓	✓	DBX1 14#(9#-18#)	5.5/13	31/34	590x230x550
MS-9100D	5000	—	✓	—	✓	✓	✓	DBX1 8#-18	5.5/15	33/38	620x255x565
MS-D1	5000	—	✓	—	✓	✓	✓	DBX1 11#-18	5/13	33/38	630x250x550
MS-V1	5000	—	✓	—	✓	✓	✓	DBX1 11#-18	5/13	33/38	630x250x550
MS-A1	5000	—	✓	—	✓	✓	✓	DBX1 11#-18	5/13	33/38	630x250x550
MS-D2	5000	✓	✓	—	✓	✓	✓	DBX1 11#-18	5/13	35/40	630x250x550
MS-A2	5000	✓	✓	—	✓	✓	✓	DBX1 11#-18	5/13	35/40	630x250x550
MS-A5	5000	✓	✓	✓	✓	✓	✓	DBX1 11#-18	5/13	38/43	630x250x550

	5000	✓	2	✓	✓	✓	✓	✓	DBX1 11-18#	5/13	40/44	660x250x540
MS-E50	5000	✓	2	✓	✓	✓	✓	✓	DBX1 11-18#	5/13	40/44	660x250x540
MS-E52	5000	✓	2	✓	✓	✓	✓	✓	DBX1 11-18#	5/13	40/44	660x250x540
MS-A6	5000	✓	2	✓	✓	✓	✓	✓	DBX1 11-18#	5/13	40/44	660x250x540
MS-8000A	5000	✓	2	✓	✓	✓	✓	✓	DBX1 11-18#	5/13	40/44	660x250x540
MS-9000-D4	5000	✓	2	✓	✓	✓	✓	✓	DBX1 11-18#	5/13	40/44	660x250x540
MS-9056-D4	5000	✓	2	✓	✓	✓	✓	4	DBX1 11-18#	5/13	70/80	1080x325x645
MS-9085-D4	5000	✓	2	✓	✓	✓	✓	4	DBX1 11-18#	5/13	90/100	1300x325x645

NEW!



**MS-A8F-C**  
单步进电脑平缝机 (密封油盘, 双刀)  
Single Stepping Motor Computerized Lockstitch  
(Double Knife & Seal Oil Pan)

1. Stepper motor motor drive, quieter and more stable;
2. Adopt new motor design, low maintenance cost, easy to replace encoder;
3. Scientific design, both thick and thin;
4. Seal oil pan, no oil worry;
5. Electronic knee control, easy seam;
6. Large air volume hand wheel, electric control box heat dissipation;
7. Super USB interface.

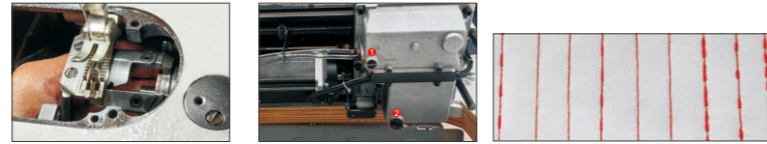

Double round knife thread cutting    Closed oil pan    9 patterns to choose

NEW!



**MS-A8F**  
单步进电脑平缝机  
Single Stepping Motor Computerized Lockstitch

1. Stepper motor motor drive, more quiet;
2. Adopt new motor design, low maintenance cost, easy to replace encoder;
3. Scientific design, both thick and thin;
4. Large air volume hand wheel, electric control box heat dissipation;
5. Super USB interface.



**MS-A7**  
单步进电脑平缝机  
Single Stepping Motor Computerized Lockstitch



**MS-GT188**  
单步进电脑平缝机  
Single Stepping Motor Computerized Lockstitch



**MS-1986**  
单步进电脑平缝机 (步进三驱)  
Single Stepping Motor Computerized Lockstitch  
(1 Stepping Motor Three Drive)

Model	Speed (S.P.M)	Scissors	Needle	Foot	Stitch	Pressure	Hand Wheel	Control Panel	Stitch Length	Stitch Width	Dimensions (mm)
MS-A8F	5000	✓	✓	✓	✓	✓	✓	DBX1 11#-18	0-7	5/13	36/40 670x270x550
MS-A8F-C	5000	✓	✓	✓	✓	✓	✓	DBX1 11#-18	0-7	5/13	36/40 670x270x550
MS-A7	5000	✓	✓	✓	✓	✓	✓	DBX1 11#-18	0-5	5/13	36/40 670x270x550
MS-GT188	5000	✓	✓	✓	✓	✓	✓	DBX1 11#-18	0-5	5/13	36/40 670x270x550
MS-1986	5000	✓	✓	✓	✓	✓	✓	DBX1 11#-18	0-5	5/13	36/40 670x270x550

NEW!



**MS-A88F**  
双步进电脑平缝机 (双刀&密封油盘)  
Double Stepping Motor Computerized Lockstitch  
(Double Knife & Seal Oil Pan)

1. Stepper motor motor drive, quieter and more stable;
2. Adopt new motor design, low maintenance cost, easy to replace encoder;
3. Scientific design, 1.5:1 both thick and thin;
4. Seal oil pan, no oil worry;
5. Electronic knee control, easy seam;
6. Large air volume hand wheel, electric control box heat dissipation;
7. Super USB interface;



9 patterns to choose    Round knife thread cutting    High quality rotary hook    Eating thick denim up to 13 layers.



**MS-R80**  
双步进高速电脑平缝机(按键屏)  
Double Stepping Motor Computerized Lockstitch  
(Button Screen)



Presser foot lifter controlled by stepping motor    Automatic motor winding device    Color screen    Stitch length and backstitch controlled by stepping motor



**MS-GT288**  
双步进电脑平缝机  
Double Stepping Motor Computerized Lockstitch



**MS-M1Pro**  
双步进电脑平缝机  
Double Stepping Motor Electronic Feed Lockstitch



**MS-M2**  
双步进电脑平缝机(触摸屏)  
Double Stepping Motor Computerized Lockstitch (Touch Screen)

Model	Speed (S.P.M)	Scissors	Needle	Foot	Stitch	Pressure	Hand Wheel	Control Panel	Stitch Length	Stitch Width	Dimensions (mm)
MS-A88F	5000	✓	✓	✓	✓	✓	✓	DBX1	0-7	6/12	38/44 620x280x545
MS-R80	4500	✓	✓	✓	✓	✓	✓	DBX1 #7-#16	0-6	6/10	38/44 620x280x545
MS-GT288	5000	✓	✓	✓	✓	✓	✓	DBX1	0-5	6/12	38/44 620x280x545
MS-M1Pro	4500	✓	✓	✓	✓	✓	✓	DBX1 #7-#16	0-6	6/10	38/44 620x280x545
MS-M2	4500	✓	✓	✓	✓	✓	✓	DBX1 #7-#16	0-6	6/10	38/44 620x280x545

**MS-1987A-NFPro**

双步进智能针送料平缝机  
Intelligent Double Stepping Motor Needle Feed Lockstitch



1. Adopts connecting rod type needle feeding structure, which makes the feeding characteristics more stable, it is not easy to slip between seam layers.
2. Bottom step motor control thread trimmer and pressing foot lifter, stable, low noise and convenience.
3. No Bearing Servo Motor: The machine connecting only with one main shaft, more rigid, torque more light, and lower motor works voice.

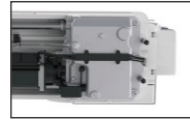

Sealed oil pan

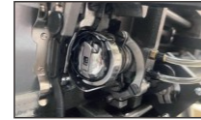

Big hook

**MS-9982-D4**

单针针送料电脑平缝机  
Needle Feed Computerized Lockstitch



1. The needle and feed dog work at the same time to create the perfect stitch;
2. With innovative design, it can sew very thin and smooth material to create the perfect stitch;
3. Strong-adaptable of fabric, especially suitable for thin material sewing;
4. Needle bar coated with DLC, high technology, durable, wearable;



Needle feed

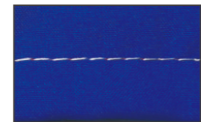

High quality rotary shuttle

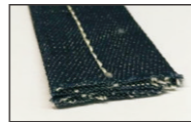

Electromagnet

**MS-9982X-D4-DB**

高速针送料带刀平缝机  
High Speed Needle Feed Lockstitch With Edge Cutter



1. The needle and feed dog work at the same time to create the perfect stitch;
2. With innovative design, it can sew very thin and smooth material to create the perfect stitch;
3. Strong-adaptable of fabric, especially suitable for thin material sewing;
4. Needle bar coated with DLC, high technology, durable, wearable;
5. Applicable to sewing all kinds of shirts, suits or similar clothes, especially the collar and the front of garment.
6. Cutters device makes sewing and trimming complete at the same time, thus improving the work efficiency.



**MS-1952Pro**

双步进针送料带刀平缝机  
Double Stepping Motor Needle Feed Lockstitch With Edge Cutter

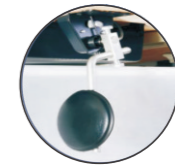
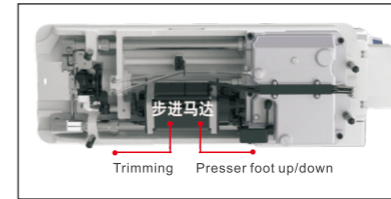

- ① Multi-function needle refill button
- ② Clutch type cutter switch
- ③ Step motor bidirectional driven technology
- ④ No Bearing Servo Motor:



**MS-DD8QB-D3**

直驱步进带刀平缝机 (切包一体)  
Direct Drive Stepping Motor Lockstitch With Side Cutter & Over-Edging Device



Customized needle gauge & folder

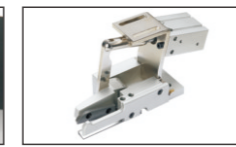

Optional: Cutting device



**MS-DD8-7**

筒式步进带刀电脑平缝机  
Stepping Motor Cylinder Bed Computerized Lockstitch With Cutter

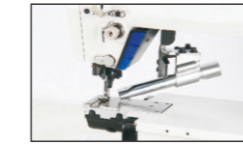

Cutting edge suction device



New independent loose wire electromagnet design

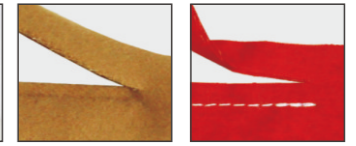

**MS-5200-D4**

电脑带刀平缝机  
Computerized Lockstitch With Cutter

**MS-5200QB-D4**

Computerized Lockstitch With Cutter & Over-Edging



**MS-7770-D4**

电脑带刀平缝机  
Computerized Lockstitch With Cutter

**MS-7770QB-D4**

Computerized Lockstitch With Cutter & Over-Edging



**MS-7770QBD**

单直驱带刀平缝机  
Direct Drive Lockstitch With Side Cutter & Over-Edging

Model	DBX	Speed	Stitch	Trim	Over-Edging	Presser	Needle	Shuttle	Electromagnet	Motor	Power	Dimensions
MS-1987A-NFPro	DBX1 #7~#16	0-5 6-12	✓	★	★	★	★	★	★	—	4500	45.3/39.2 620x280x545
MS-9982-D4	DBX1 #9~#18	0-5 5.5-13	✓	✓	✓	★	★	★	✓	—	4500	38/45 720x245x523
MS-9982X-D4-DB	DBX1 #9~#18	0-5 5.5-13	✓	✓	✓	★	★	★	✓	—	4500	38/45 720x245x523

Model	Speed	Trim	Over-Edging	Presser	Needle	Shuttle	Electromagnet	Motor	Power	Dimensions
MS-1952Pro	4500	✓	✓	✓	✓	✓	✓	✓	DBX1 7#-16#	0-5 6/10 40/46 620x280x545
MS-DD8QB-D3	4500	✓	✓	✓	✓	✓	✓	✓	DBX1 8#-18#	0-5 4/9 35/44 625x250x560
MS-DD8-7	4000	✓	✓	✓	✓	✓	✓	✓	DBX1 8#-18#	0-5 4/9 35/44 625x250x560
MS-5200-D4 MS-5200QB-D4	4500	✓	✓	✓	✓	✓	✓	✓	DBX1 9#-22#	0-5 4/9 38/43 670x250x580
MS-7770-D4 MS-7770QB-D4	5000	✓	✓	✓	✓	✓	✓	✓	DBX1 9#-18#	0-5 6/9 49/51 630x225x550
MS-7770QBD	5000	—	✓	✓	✓	✓	✓	✓	DBX1 9#-18#	0-5 6/9 49/51 630x225x550

**MS-S5490-A/SX**

筒式步进电脑上差动平缝机 (分段编程)  
Stepping Motor Cylinder Bed Upper Differential  
Computerized Lockstitch (Sectional Programming)

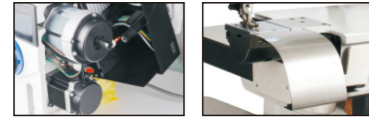

Stepper motor  
adjustment differential

**PK**

Traditional mechanical  
adjustment differential

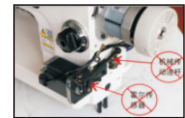

羽绒服工艺分解

Down Jacket Process Decomposition



① 袖口拉松紧

② 上袖口

③ 上拉链

④ 合缝

⑤ 门襟止口

⑥ 上袖



① 袖口拉松紧 **MS-S5490-SX**



1. It is convenient for sewing small-diameter round materials, and can be equipped with an auxiliary device to achieve elastic sewing of cuffs.
2. Stepping motor controls of stitch length and backstitch

② 上袖口 **MS-S5490-SX**



1. Cylinder bed is perfectly suitable for sewing the cuffs.
2. Integrating the main servo system and auxiliary programming system into one
3. Using servo motors to control the capacity of each segment, it can be divided into up to 9 segments
4. Suitable for various fabrics

③ 上拉链 **MS-5493-K**



1. With upper and lower differential feeding function.
2. Application for various step of sewing.
3. The zipper is sewn to even fit with the clothing.

④ 合缝 **MS-5490A-D4**



1. The sewing stitches is more beautiful on elastic ultra-thin fabrics, and the material feeding is more smoother on thick materials.
2. For sewing fabrics with unequal lengths, perfect stitching can be completed through differential programming.

⑤ 门襟止口 **MS-5490A-D4**



1. The sewing stitches is more beautiful on elastic ultra-thin fabrics, and the material feeding is more smoother on thick materials.
2. For sewing fabrics with unequal lengths, perfect stitching can be completed through differential programming.

⑥ 上袖 **MS-S5490-A/SX**



1. Integrating the main servo system and auxiliary programming system into one.
2. Using servo motors to control the capacity of each segment, it can be divided into up to 9 segments.
3. Adapt to the sewing needs of various fabrics (general fabrics/iron-free fabrics/chiffon/velvet fabrics, etc.).



**MS-1949**

双步进智能上差动送料平缝机  
Double Stepping Motor Intelligent Upper Differential Feed Lockstitch



**MS-5490A-D4**

步进电脑上差动平缝机  
Stepping Motor Upper Differential Computerized Lockstitch



**MS-5493-K**

上下差动电脑平缝机(K-快速切换)  
Upper And Lower Differential Computerized Lockstitch  
(K-Quick Switch)



**MS-5490B-D4**

步进电脑下差动平缝机  
Stepping Motor Lower Differential Computerized Lockstitch



**MS-5499-7K**

上下差动电脑平缝机  
Upper And Lower Differential Computerized Lockstitch



**MS-S5490-SX**

筒式上差动平缝机  
Cylinder Bed Upper Differential Computerized Lockstitch

Model	Needle	Stitch Length	Stitch Width	Max. Sewing Speed	Max. Sewing Width	Max. Sewing Length	Max. Sewing Thickness	Max. Sewing Weight	Max. Sewing Length	Max. Sewing Width
MS-1949	DBX1 #7-#16	0-6	6-12	31.8	★	★	★	4500	45.8/39.7	620x280x545
MS-5490A-D4	DBX1 7-18#	0-4	5-13	31.8	★	★	★	4000	39/45	680x250x530
MS-5493-K	DBX1 7-18#	0-4	5-13	31.8	★	★	★	4000	39/45	680x250x530
MS-5490B-D4	DBX1 7-18#	0-4	5-13	31.8	★	★	★	4000	39/45	680x250x530
MS-5499-7K	DBX1 7-18#	0-4	5-13	31.8	★	★	★	4000	39/45	680x250x530
MS-S5490-SX	DBX1 7-18#	0-4	5-13	31.8	★	★	★	4000	39/45	680x250x530

**MS-R88**  
多轴驱动高速智能数字型平缝机  
Multiple Motor Drive High Speed Intelligent Digital Lockstitch



- 1.Auto thread trimmer,auto presser foot lifter, backstitch
- 2.Adopt multiple motor driven, which is more stable and brisk.
3. Stepping motor controls the stitch length
4. Large working area: 305mm
- 5.Automatic winding at startup

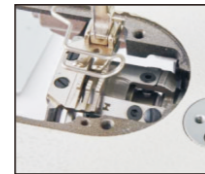

Double knife

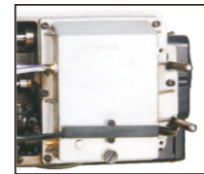

Sealed oil pan

**MS-D8A-7**  
筒式步进电脑自动平缝机  
Stepping Motor Cylinder Bed Computerized Lockstitch



It is suitable for the cuffs and elastic cuffs of denim trousers, the cuffs of cotton jackets and down jackets, the butt jointing of threaded cuffs and sleeve bodies, and the waist tightening of children's clothing, sport pants, and sweatpants.

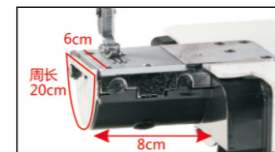

For small diameter circular material sewing

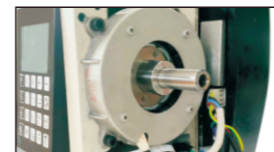

New sewing machine upper shaft and spindle motor  
Coaxial drive, no coupling

**MS-R80S**  
步进筒式高速电脑平缝机  
Stepping Motor Cylinder Bed Computerized Lockstitch

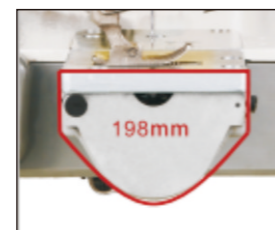

Cylinder circumference is 198mm

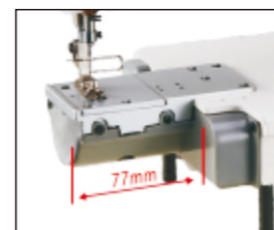

Cylinder length is 77mm

	DBX1 11#-18	1	0-5	★	★	★	★	5/13	5000	40/47	700x250x560
MS-R88	DBX1 11#-18	1	0-5	★	★	★	★	5/13	5000	40/47	700x250x560
MS-D8A-7	DBX1 8#-18	1	0-5	★	★	★	★	4-9	4000	38/44	625x250x560
MS-R80S	DBX1 8#-18	1	0-5	★	★	★	★	4-9	4000	43/50	625x250x560



**MS-8750A/8450A**  
双步进双针平缝机  
Double Stepping Motor Double Needle  
Computerized Lockstitch (Large Hook/Small Hook)



**MS-8720L**  
直驱双针长臂平缝机  
Long Arm Direct Drive Double Needle Lockstitch



**MS-8752E/8452E/8722E/8422E**  
一体嵌入屏电脑双针平缝机  
Integrated Double Needle Computerized Lockstitch



**MS-8752D/8452D/8722D/8422D**  
一体直驱双针平缝机  
Integrated Double Needle Direct Drive Lockstitch



**MS-872D/842D/875D/845D**  
单直驱双针平缝机  
Double Needle Direct Drive Lockstitch



**MS-8752B/8420B-D4**  
电脑双针平缝机  
Double Needle Computerized Lockstitch  
(Copy Brother Motor)



**MS-8752P/8420P-D4**  
电脑双针平缝机  
Double Needle Computerized Lockstitch  
(Powermax Motor)

Model	Needle	Stitch	Stitch Length	Stitch Width	Speed (S.P.M)	Stitch Length Range	Stitch Width Range	Max. Sewing Speed	Max. Sewing Width	Max. Sewing Length	Dimensions (mm)
MS-8750A/8450A	DPX5 14#-22#	2	★	1/8" 5/32" 7/32"	7/13	✓	★	4500	★	★	58/66 715x305x630
MS-8720L	DPX5 11#-21#	3	★	1/8" 5/32" 7/32"	7/13	✓	✓	3000	✓	✓	60/65 1100x330x660
MS-8752E/8452E/8722E/8422E	DPX5 11#-16#	2	★	1/8" 5/32" 7/32"	7/13	✓	✓	4500	★	★	42/47 750x255x580
MS-8752D/8452D/8722D/8422D	DPX5 11#-16#	2	★	1/8" 5/32" 7/32"	7/13	✓	✓	4500	—	—	42/47 750x255x580
MS-872D/842D/875D/845D	DPX5 11#-16#	2	★	1/8" 5/32" 7/32"	7/13	✓	★	4500	—	—	42/47 750x255x580
MS-8752B/8420B-D4	DPX5 11#-16#	2	★	1/8" 5/32" 7/32"	7/13	✓	★	4500	★	★	42/47 750x255x580
MS-8752P/8420P-D4	DPX5 11#-16#	2	★	1/8" 5/32" 7/32"	7/13	✓	★	4500	★	★	42/47 750x255x580

**MS-3846/3883**

长臂直驱电脑链式平缝机 (46/83CM)  
Long Arm Direct Drive Computerized Chain Stitch Lockstitch  
(46cm/83cm)

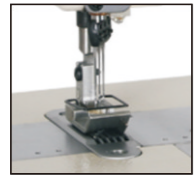

Pin shaped three needle



Oblique three needle

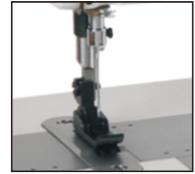

Single needle



Double needle

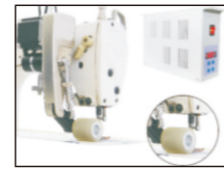

Optional: Electronic Puller

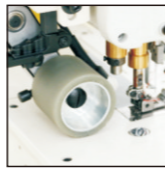

Mechanical Puller

This machine adopts link-typed feeding mechanism needle bar thread taking up, and looper thread catching, to produce two lines of chain stitch, which is firm and elastic, suitable for lapping seam and decorative seam on garment, underwear, bedding articles and leather goods. there are five different gauges available for selection.

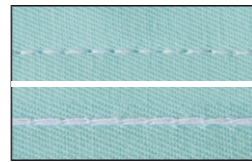

MS-3800D-1

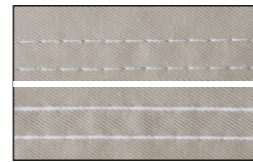

MS-3800D-2

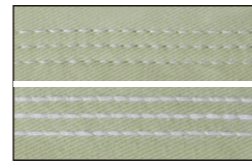

MS-3800D-3



**MS-3800D-PL(1/2/3)**

直驱高速链式平缝机 (带拖轮)  
Direct Drive High Speed Chain Stitch Lockstitch With Back Puller  
(1 Needle/2 Needle/3 Needle)



**MS-3800D-1/2/3**

直驱高速链式平缝机  
Direct Drive High Speed Chain Stitch Lockstitch  
(1 Needle/2 Needle/3 Needle)

Model	TV	Needles	Stitch	Feeding	Speed	Star	Star	Star	Star	Star	Dimensions	Weight
MS-3846	TV x 7	3	6	5.5-10	3	★	★	★	★	4	4000 850X250X486	50/53
MS-3800D-1	TV x 7	1	2	5.5-10	1	★	★	★	★	4	4500 665X250X486	33/41
MS-3800D-2	TV x 7	2	4	5.5-10	2	★	★	★	★	4	4500 665X250X486	33/41
MS-3800D-3	TV x 7	3	6	5.5-10	3	★	★	★	★	4	4000 665X250X486	33/41
MS-3800D-PL-1	TV x 7	1	2	5.5-10	1	★	★	★	★	4	4500 665X250X486	33/41
MS-3800D-PL-2	TV x 7	2	4	5.5-10	2	★	★	★	★	4	4500 665X250X486	33/41
MS-3800D-PL-3	TV x 7	3	6	5.5-10	3	★	★	★	★	4	4000 665X250X486	33/41

Heavy-duty  
Walking Foot Series  
厚料系列



NEW!



**MS-M7**

1. Double-stepping design improves efficiency;
2. One stepping motor controls stitch length adjustment and backstitch functions, the stitch length is precise. The maximum stitch length is 10mm;
3. Another stepping motor controls thread trimming and presser foot lifting functions.



**MS-M7**

双步进上下送料平缝机  
Double Stepping Motor Computerized Top And Bottom Feed Lockstitch



**MS-0303-D4-56/85/100**

上下送料加长电脑平缝机 (加长56cm/ 85cm/100cm)  
Long Arm Computerized Top And Bottom Feed Lockstitch (56cm/ 85cm/ 100cm)

1. Direct drive servo motor, large operation space, using the fine cloth feeding mechanism, in the low tension condition can prevent high speed beating, greatly improves the production efficiency.
2. The built-in winder, beautiful appearance, convenient operation. Low noise, no radiation, environmental protection type.
3. Can be adapted to clothing, packaging, footwear and other industries, in the thick material sewing.



**MS-0303D**

上下送料直驱平缝机  
Direct Drive Top And Bottom Feed Lockstitch



**MS-1933**

双步进上下送料平缝机 ( 加长33cm)  
Double Stepping Motor Computerized Top And Bottom Feed Lockstitch (13"=33cm)

**MS-M8**

单步进上下送料平缝机  
Single Stepping Motor Computerized Top And Bottom Feed Lockstitch



**MS-K5-33**

单针加长上下送料平缝机 ( 33cm)  
Long Arm Single Needle Computerized Top And Bottom Feed Lockstitch (13"=33cm)

**MS-267**

单针或双针综合送料平板缝纫机  
Single/Double Needle Compound Feed Flat Bed Sewing Machine



**MS-0303-D4**

上下送料电脑平缝机  
Computerized Top And Bottom Feed Lockstitch



**MS-0303-D4-33**

上下送料加长电脑平缝机  
Long Arm Computerized Top And Bottom Feed Lockstitch (13"=33cm)



**MS-0388-D4**

上下送料电脑平缝机  
Computerized Top And Bottom Feed Lockstitch

Model	S.p.m	Scissors	Presser Foot	Stitch Length	Stitch Width	Stitch Density	Stitch Length	Stitch Width	Stitch Density	Dimensions
MS-M7	2500	✓	2	12mm	✓	DPX17	0-10	8/12	46/48	715X305X630
MS-1933	2500	✓	2	12mm		DPX17	0-10	8/12	47/52	715X305X630
MS-M8	2500	✓	2	12mm	✓	DPX17	0-10	8/12	46/48	715X305X630
MS-K5-33	2500	✓	2	12mm	✓	DPX17	0-8	6/13	50/53	730X330X570
MS-267	2500		2	12mm	✓	134-35 110-140	—	6-10	37/48	700x330x720

Model	S.p.m	Scissors	Presser Foot	Stitch Length	Stitch Width	Stitch Density	Stitch Length	Stitch Width	Stitch Density	Dimensions	
MS-0303-D4-56	2200	2	★	★	3.5-5.5	8	★	DPX17 18-23#	6/13	72/76	1040x340x610
MS-0303D	2200	2	★	★	3.5-5.5	8	★	DPX17 18-23#	6/13	33/35	570x250x540
MS-0303-D4	2200	2	★	★	3.5-5.5	8	★	DPX17 18-23#	6/13	33/35	570x250x540
MS-0303-D4-33	2200	2	★	★	3.5-5.5	8	★	DPX17 18-23#	6/13	33/35	570x250x540
MS-0388-D4	2200	2	★	★	3.5-5.5	8	★	DPX17 18-23#	6/13	33/35	570x250x540

**MS-6400-D4**

上下送料四自动同步平缝机  
Computerized Top And Bottom Feed Lockstitch



- 1.The use of built-in servo motor direct drive to achieve a very fast start and braking accurately;
- 2.The use of large rotary hook, reduce the number of times of replacing the bobbin thread, improve the work efficiency;
- 3.Application for high-end product, like footwear, bags, car upholstery, sofa, balls and so on.



Special thread clamp device for ball

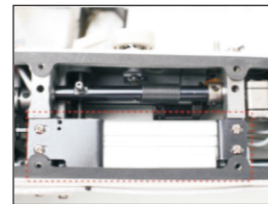

Built-in pneumatic automatic presser foot device

**MS-640-D4**

上下送料四自动同步平缝机 (加长37cm)  
Long Arm Computerized Top And Bottom Feed Lockstitch (37cm)



Loose wire electromagnet



Vertical bobbin winder, Adjustable inside and outside presser foot lifting

**MS-9312/9322-D4**

上下送料四自动平缝车  
Computerized Top And Bottom Feed Lockstitch



**MS-9612/9622-D4**

长臂综合送料四自动平缝机 (加长37cm)  
Long Arm Computerized Compound Feed Lockstitch (37cm)



Model	S.p.m	Icon 1	Icon 2	Icon 3	Icon 4	Icon 5	Icon 6	Icon 7	Icon 8	Icon 9	Icon 10	Icon 11	Icon 12
MS-6400-D4	3000	✓	✓	✓	✓	✓	✓	✓	DPX17	0-8	6/13	49/53	780X250X530
MS-640-D4	3000	—	✓	✓	✓	—	—	—	DPX17	0-8	6/13	49/53	780X250X530
MS-9312/9322-D4	2200	2	✓	✓	✓	✓	✓	✓	DPX17 11-18#	0-8	6/13	41/43	705X255X580
MS-9612/9622-D4	2200	2	✓	✓	✓	✓	✓	✓	DPX17 11-18#	0-8	6/13	41/43	705X255X580



**MS-K6-33**

综合送料单针电脑平缝机  
Single Needle Computerized Compound Feed Lockstitch (13"=33cm)



**MS-0617B-7C**

综合送料单针电脑平缝机  
Single Needle Computerized Compound Feed Lockstitch



**MS-0617B-7C-46**

综合送料单针加长电脑平缝机  
Long Arm Single Needle Computerized Compound Feed Lockstitch (18"=46cm)



**MS-0628D**

综合送料单针直驱平缝机  
Single Needle Direct Drive Compound Feed Lockstitch



**MS-1245**

单针综合送料平缝机  
Single Needle Compound Feed Lockstitch



**MS-4400D/4420D**

单针/双针综合送料直驱平缝机  
Direct Drive Single Needle/ Double Needle Compound Feed Lockstitch Sewing Machine



**MS-20618-1-D4  
MS-20618-2-D4**

综合送料单针/双针电脑平缝机  
Computerized Single/Double Needle Compound Feed Lockstitch



**MS-4400-D4-25  
MS-4420-D4-25**

单针/双针综合送料加长电脑平缝车  
Long Arm Computerized Single/ Double Needle Compound Feed Lockstitch(25")



**MS-20618-1-25  
MS-20618-2-25**

单针/双针综合送料加长平缝车  
Long Arm Single/ Double Needle Compound Feed Lockstitch(25")

Model	S.p.m	Icon 1	Icon 2	Icon 3	Icon 4	Icon 5	Icon 6	Icon 7	Icon 8	Icon 9	Icon 10	Icon 11	Icon 12
MS-K6-33	2500	✓	✓	✓	✓	✓	✓	✓	DPX17	0-8	6/13	50/53	730X330X570
MS-0617B-7C	2000	✓	✓	✓	✓	✓	✓	✓	DPX17	0-8	6/12	46/48	650X270X550
MS-0617B-7C-46	2000	✓	✓	✓	✓	✓	✓	✓	DPX17	0-8	6/12	46/48	650X270X550
MS-0628D	2000	—	—	—	✓	✓	✓	✓	DPX17	0-9	6/12	46/48	650X270X550
MS-1245	2000	—	—	—	✓	✓	✓	✓	DPX35LR 90-150	0-8	10/15	46/48	650X270X550
MS-4400D	2000	—	—	—	✓	✓	✓	✓	DPX17	0-9	6/12	46/48	650X270X550
MS-4420D	2000	—	—	—	✓	✓	✓	✓	DPX17	0-9	6/12	46/48	650X270X550
MS-20618-1-D4	2000	✓	✓	✓	✓	✓	✓	✓	DPX17	0-9	6/12	46/48	650X270X550
MS-20618-2-D4	2000	✓	✓	✓	✓	✓	✓	✓	DPX17	0-9	6/12	46/48	650X270X550
MS-4400-D4-25	2000	✓	✓	✓	✓	✓	✓	✓	DPX17	0-9	6/12	58/63.9	1140X700X320
MS-4420-D4-25	2000	✓	✓	✓	✓	✓	✓	✓	DPX17	0-9	6/12	58/63.9	1140X700X320
MS-20618-1-25	2000	—	—	—	✓	✓	✓	✓	DPX17	0-9	6/12	58/63.9	1140X700X320
MS-20618-2-25	2000	—	—	—	✓	✓	✓	✓	DPX17	0-9	6/12	58/63.9	1140X700X320



**MS-1510AE**  
单针综合送料切包一体平缝机  
Single Needle Compound Feed Lockstitch Sewing Machine With Edge Cutter & Binding



**MS-1541S**  
单针综合送料平缝机 (旋梭分线装置)  
Single Needle Compound Feed Lockstitch Sewing Machine With Safety Mechanism



**MS-335PF**  
单针筒式综合送料平缝机  
Single Needle Cylinder Bed Compound Feed Lockstitch Sewing Machine



**MS-1342-7D**  
双针筒式电脑综合送料平缝机  
Computerized Double Needle Cylinder Bed Compound Feed Lockstitch Sewing Machine



**MS-1565**  
双针针杆分离综合送料平缝机  
Double Needle Compound Feed Lockstitch With Split Needle Bar



**MS-1510-7**  
**MS-1560-7**  
单针/双针电脑综合送料平缝机  
Computerized Single Needle/ Double Needle Compound Feed Lockstitch Sewing Machine (Goolee Motor)



**MS-335TD**  
单针筒式电脑综合送料平缝机  
Computerized Single Needle Cylinder Bed Compound Feed Lockstitch Sewing Machine



**MS-335A**  
单针筒式综合送料平缝机 (包边)  
Single Needle Cylinder Bed Compound Feed Lockstitch Sewing Machine For Binding



**MS-1341**  
单针筒式综合送料平缝机  
Single Needle Cylinder Bed Compound Feed Lockstitch Sewing Machine



**MS-1510-7D**  
**MS-1560-7D**  
单针/双针电脑综合送料平缝机  
Computerized Single Needle/ Double Needle Compound Feed Lockstitch Sewing Machine (Powermax Motor)



**MS-1510-18/25/40-7**  
**MS-1560-18/25/40-7**  
单针/双针加长电脑综合送料平缝机 (18inch/25inch/40inch)  
Long Arm Computerized Single Needle/ Double Needle Compound Feed Lockstitch Sewing Machine (18"/ 25"/ 40")



**MS-2628**  
单针筒式自动注油综合送料平缝机  
Single Needle Cylinder Bed Compound Feed Lockstitch Sewing Machine With Automatic Oil-Lubrication



**MS-8BD**  
单针筒式直驱综合送料平缝机  
Direct Drive Single Needle Cylinder Bed Compound Feed Lockstitch Sewing Machine



**MS-246**  
单针筒式综合送料平缝机  
Single Needle Cylinder Bed Compound Feed Lockstitch Sewing Machine

Model	S.p.m	L	M	H	Needle	Foot	Table	Arm	Stitch	Stitch Length	Stitch Width	Table Size
MS-1510AE	2000	✓	✓	✓	DPX17 18#-25#	•	•	260X103	10	8/16	58/66	735x340x700
MS-1541S	2500	✓	✓	✓	DPX17 23#	•	•	260X103	0-9	9/16	58/66	735x340x700
MS-1565	2500	✓	✓	✓	DPX17 23#	•	•	260X103	0-9	9/16	58/66	735x340x700
MS-1510-7	2500	✓	✓	✓	DPX17 23#	•	•	260X103	—	9/16	58/66	735x340x700
MS-1560-7	2500	✓	✓	✓	DPX17 23#	•	•	260X103	3.2-31.8	9/16	58/66	735x340x700
MS-1510-7D	2500	✓	✓	✓	DPX17 23#	•	•	260X103	—	9/16	58/66	735x340x700
MS-1560-7D	2500	✓	✓	✓	DPX17 23#	•	•	260X103	3.2-31.8	9/16	58/66	735x340x700
MS-1510-18-7	2000	✓	✓	✓	DPX17 18#-25#	•	•	635X103	3.2-31.8	9/16	58/66	735x340x700

Model	Needle	Foot	Stitch	Stitch Length	Stitch Width	Table	Arm	Stitch	Stitch Length	Stitch Width	Table Size
MS-335PF	DP×17	1	0-5.5	8-16	✓	—	★	★	★	★	46 2200
MS-1342-7D	DP×17	2	0-11	15	—	✓	★	★	★	★	70 2200
MS-335TD	DP×17	1	0-11	15	✓	—	★	★	★	★	70 2200
MS-335A	DP×17	1	0-5.5	8-16	✓	—	★	★	★	★	46 2200
MS-1341	DP×17	1	0-11	15	—	✓	★	★	★	★	70 2200
MS-2628	DP×17	1	0-5	6-16	✓	—	★	★	★	★	50 2200
MS-8BD	DP×17	1	0-7.5	14	✓	—	★	★	★	★	65 2200
MS-246	DP×17	1	0-9	15	✓	—	★	★	★	★	50 2200

1. The powerful feeding system with bottom feed, needle feed and alternating top feed guarantees trouble-free and displacement-free material feed;
2. The lifting height of presser foot up to 20 mm which facilitates the feeding and removing of heavy weight materials;
3. The high top feed stroke up to 9 mm allows a safe climbing over differently high material plies;
4. Large working space (335mm width and 295mm height) which is easier for sewing large area materials.

**MS-867**

综合送料电脑平缝机  
Computerized Compound Feed Lockstitch Sewing Machine



**Applications**



**Code diagram**

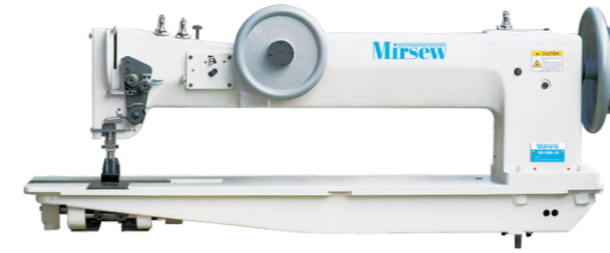
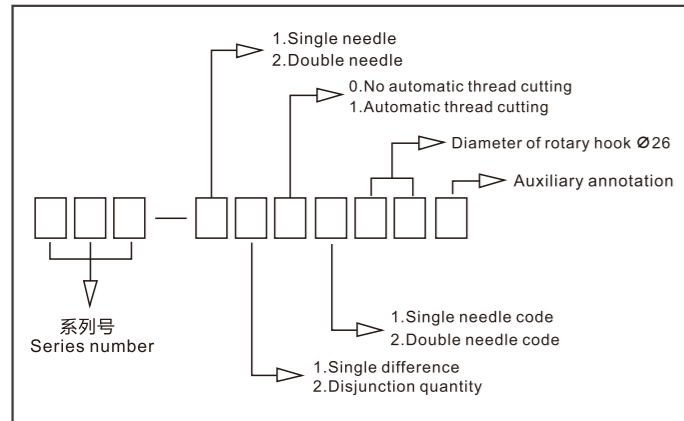

**MS-28BL-15/20/30**

单针/双针长臂综合送料厚料平缝机  
Long Arm Single Needle/ Double Needle Compound Feed Lockstitch Sewing Machine (15"/ 20"/ 30")



**MS-461/446**

筒式加长综合送料平缝机 ( 960mm/635mm)  
Long Arm Cylinder Bed Compound Feed Lockstitch Sewing Machine (960mm/ 635mm)



**MS-254**

单针上下复合送料极厚料平缝机  
Single Needle Top And Bottom Feed Lockstitch Sewing Machine For Extra Thick Material

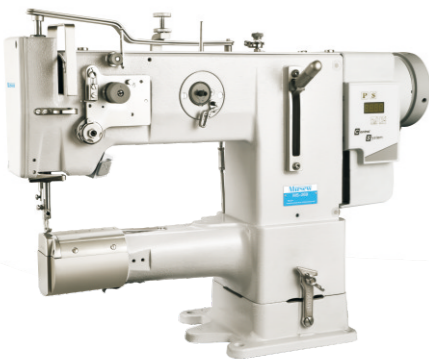

**MS-269**

筒式单针综合送料平缝机  
Cylinder Bed Single Needle Compound Feed Lockstitch Sewing Machine



**MS-669**

筒式综合送料平缝机  
Cylinder Bed Compound Feed Lockstitch Sewing Machine



**MS-868**

双针高台式综合送料平缝机  
Double Needle Post Bed Compound Feed Lockstitch Sewing Machine



**MS-441**

筒式综合送料平缝机  
Cylinder Bed Compound Feed Lockstitch Sewing Machine



**MS-243/246/263**

单针综合送料特厚料平缝机  
Long Arm Single Needle Compound Feed Lockstitch Sewing Machine For Extra Thick Material

Model	Speed (r.p.m)	Scissors	Trimmer	Needle	L	M	H	I	H	mm	mm	mm
MS-868	2500	✓	✓	✓	✓	✓	✓	DPX35	0-9	0-20	37/48	745X370X875
MS-269-373	2000							134-35 110-140	-	6-10	37/48	700x330x720
MS-269-273	2000							134-35 110-140	4.8-24	6-10	37/48	700x330x720
MS-867	3000	✓	-	✓	✓	✓	✓	DPX35	0-9	0-20	37/48	745X370X705
MS-669	3000	✓	✓	✓	✓	✓	✓	DPX35	0-7	0-20	46/48	630X290X555

Star	Star	Star	Star	Star	Star	Star	Star	Star	Star	Star	Star	HP
*	*	*	*	*	*	*	*	*	*	*	*	*

Model	Needle	1	2	mm	mm	mm	mm	mm	mm	mm	mm	mm	mm	mm	mm	mm	mm
MS-28BL-15/20/30	DY×3 27#	2	3	12.7	0-10	20-23	★	✓	★	-	★	★	762x153	1200			
MS-461	DY×3 27#	1	2	-	0-11	13-23	★	✓	★	-	★	★	960×180	800			
MS-254	DDX1 27#	1	2	-	0-12.7	12.7-18	★	✓	★	-	★	★	430x180	1200			
MS-441	DY×3	1	2	-	0-11	13-20	★	✓	★	-	★	★	420×180	800			
MS-243/246/263	DY×3	1	2	-	0-15	13-23	★	✓	★	-	★	★	420×180	800			

1. Efficient and powerful triple feeding system, high top feed stroke and high presser foot lifter height, which facilitates the feeding and removing of heavy weight materials.
2. The 762mm large working space provides ideal conditions for large area high-quality sewing.
3. The large shuttle hook and the large-capacity bobbin to reduce the frequency of bobbin replacements.

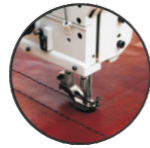

**MS-204-762**  
单针长臂综合送料厚料平缝机  
Long Arm Single Needle Compound Feed Lockstitch Sewing Machine  
For Extra Thick Material(762x185mm)



**MS-221-762**  
单/双针综合送料厚料平缝机  
Long Arm Single Needle/ Double Needle Compound  
Feed Lockstitch Sewing Machine(762x160mm)



**MS-204-420**  
综合送料厚料平缝机  
Compound Feed Lockstitch Sewing Machine



**MS-204-370-2L**  
双针卧式综合送料特厚料平缝机  
Double Needle Compound Feed Lockstitch Sewing Machine  
For Extra Thick Material



**MS-205-370**  
筒式综合送料厚料平缝机  
Cylinder Bed Compound Feed Lockstitch  
Sewing Machine



# Overlock Sewing Machine Series

## 包缝机系列

	针	脚	送料	压脚	送料	送料	送料	送料	送料	送料	送料	送料	送料	送料
MS-204-420	DY×3	1	2	—	0-12	15-20	★	—	★	—	★	★	420×185	800
MS-204-370-2L	DY×3	1	2	—	0-12	15-20	★	—	★	—	★	★	310×185	800
MS-205-370	DY×3 27#	1	2	—	0-11	13-25	★	—	★	—	★	★	310×185	800
MS-204-762	DY×3 27#	1	2	—	0-10	12-20	★	—	★	—	★	★	762×185	800
MS-221-762	DY×3 27#	1	2	—	0-6	12-20	★	—	★	—	★	★	762×160	1200



**MS-747FC/UT**  
四线一体自动剪线包缝  
Direct Drive 4 Thread Overlock Sewing Machine With Auto Trimmer



**MS-747FN**  
四线一体直驱包缝机  
Direct Drive 4 Thread Overlock Sewing Machine



**MS-GT90BN**  
智能超高速步进全自动包缝机  
Automatic Overlock Sewing Machine With Stepping Motor

- 1.The machine adopts built-in direct drive motor, with manual, semi-automatic, automatic three modes for users to choose;
- 2.The maximum speed is 7000 r / min;
- 3.The machine saves power more than 60% while improving the production efficiency of more than 30%;
- 4.It's suitable for knitted underwear, light, medium and heavy clothing and leather products.



**MS-747FD**  
四线直驱包缝机  
Direct Drive 4 Thread Overlock Sewing Machine



**MS-747D/BK**  
四线自动倒回缝包缝机  
Direct Drive 4 Thread Overlock Sewing Machine With Back Stitch



**MS-737XB**  
三线细边包缝机  
3 Thread Overlock For Handker Chief (Narrow Edging)



**MS-GR90ND**  
超高速全智能电脑步进包缝机  
Automatic Overlock Sewing Machine With Stepping Motor

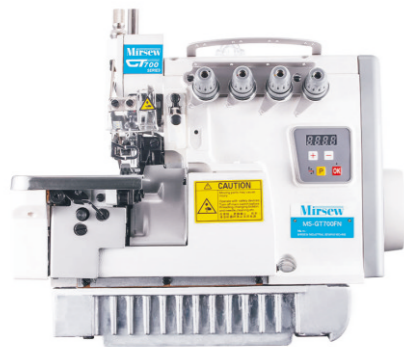
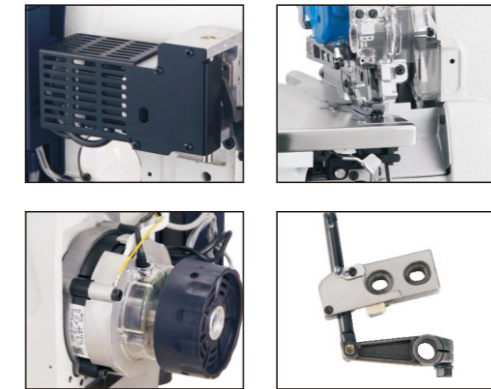

**MS-700FN**  
一体直驱包缝机  
Direct Drive Overlock Sewing Machine



**MS-700D/BK**  
直驱倒回缝包缝机  
Direct Drive Overlock Sewing Machine With Back Stitch



**MS-700-4/02X250**  
四线双链滚边包缝机 ( 口袋专用 )  
4 Thread Double Chain Binding Overlock Sewing Machine (For Pocket)



**MS-GL90B**  
超高速全自动电脑包缝机  
Super High Speed Automatic Overlock Sewing Machine



**MS-GL92BD**  
智能超高速全自动包兜机  
Super High Speed Automatic Overlock Sewing Machine For Pocket Binding



**MS-GT90BNT**  
超高速步进全自动上差动包缝机  
Upper Differential Automatic Overlock Sewing Machine With Stepping Motor

Model	DCX27 11#	2	2	4	5	0.5-3.8	5.5	0.7-2	5000	32/33.5	470x350x480
MS-747FC/UT	DCX27 11#	2	2	4	5	0.5-3.8	5.5	0.7-2	5000	32/33.5	470x350x480
MS-747FN	DCX27 11#	2	2	4	5	0.5-3.8	5.5	0.7-2	5000	32/33.5	470x350x480
MS-747FD	DCX27 11#	2	2	4	5	0.5-3.8	5.5	0.7-2	5000	32/33.5	470x350x480
MS-747D/BK	DCX27 11#	2	2	4	5	0.5-3.8	5.5	0.7-2	5000	32/33.5	470x350x480
MS-737XB	DCX27 11#	1	-	3	4	3.8	5.5	0.7-2	6500	32/33.5	470x350x480
MS-700FN	DCX27 11#	2	2	4	5	0.5-3.8	5.5	0.7-2	5000	32/33.5	470x350x480
MS-700D/BK	DCX27 11#	2	2	4	5	0.5-3.8	5.5	0.7-2	5000	32/33.5	470x350x480
MS-700-4/02X250	DCX27 11#	2	5	2	4	0.5-3.8	5.5	0.7-2	6000	32/33.5	470x350x480

Model	DCX27 11#	2	2	4	6	0.6-3.8	5.5	0.7-2.0	7000	32/40	470x330x480
MS-GT90BN	DCX27 11#	2	2	4	6	0.6-3.8	5.5	0.7-2.0	7000	32/40	470x330x480
MS-GR90ND	DCX27 11#	2	2	4	4	0.6-3.8	6	0.7-2.0	7000	29/36	515x360x560
MS-GL90B	DCX27 11#	2	2	4	4	0.6-3.8	5.5	0.7-2.0	7500	32/40	470x330x480
MS-GL92BD	DCX27 11#	2	2	4	4	0.6-3.8	5.5	0.7-2.0	7500	32/40	470x330x480
MS-GT90BNT	DCX27 11#	2	2	4	4	0.6-3.8	5.5	0.7-2.0	7500	32/40	470x330x480



**MS-C7**  
超高速步进全自动四线电脑包缝机  
Automatic 4 Thread Overlock Sewing Machine With Stepping Motor

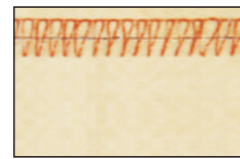

2 thread connect stitch

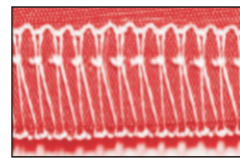

3 thread stitch

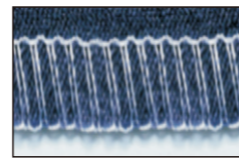

4 thread stitch

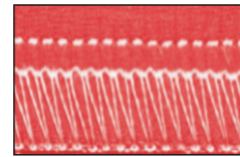

5 thread stitch



4-needle 6 thread stitch



Thin outline stitch



**MS-GR99DT**  
上差动小嘴高速一体包缝机  
Direct Drive Cylinder Bed Overlock Sewing Machine With Upper Differential



**MS-GL99BT-MF**  
多功能型上差动筒式电脑包缝机  
Multi-Functional Cylinder Bed Overlock Sewing Machine With Upper Differential



**MS-6800UT**  
高速智能四线全自动包缝机  
Automatic 4 Thread Overlock Sewing Machine



**MS-958D/UT**  
智能四线全自动包缝机  
Automatic 4 Thread Overlock Sewing Machine



**MS-EX5214D/UT**  
高速四线全自动包缝机  
Automatic 4 Thread Overlock Sewing Machine

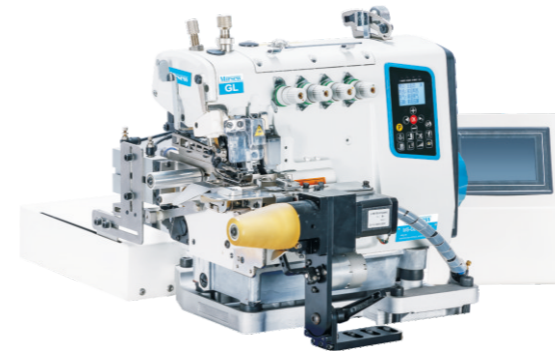

**MS-GL99BT-K2**  
自动上圆领上下差动筒式包缝机  
Automatic Cylinder Bed Collar Feeding Overlock Sewing Machine With Upper Differential



**MS-GL99BT-K1**  
上下差动筒形包缝机  
Cylinder Bed Overlock Sewing Machine With Upper Differential



**MS-EX5214D**  
高速直驱包缝机  
High Speed Direct Drive Overlock Sewing Machine



**MS-EXT5214D**  
高速直驱上差动包缝机  
High Speed Direct Drive Overlock Sewing Machine With Upper Differential



**MS-EXT5214D/UT**  
高速上差动全自动包缝机  
High Speed Automatic Overlock Sewing Machine With Upper Differential



**MS-EXT5100D**  
直驱差动小嘴包缝机  
Differential Direct Drive Small Cylinder Bed Overlock Sewing Machine



**MS-EXT3216D-LF**  
上差动直驱左手包缝机  
Direct Drive Overlock Sewing Machine With Upper Differential (Left Hand)



**MS-EXT5214D/UT-LF**  
上差动左手全自动包缝机  
Automatic Overlock Sewing Machine With Upper Differential (Left Hand)

Model	Needles	2	3	4	5	Stitch Length	Stitch Width	Speed	Stitch Density	Dimensions
MS-C7	DCX27 14#	2	2	4	5	0.5-3.8	5.5	0.7-2.0	7500	42/45 480x355x540
MS-6800UT	DCX27 14#	2	2	4	5	3.8	5.5	0.7-2.0	7500	42/45 480x355x540
MS-958D/UT	DCX27 14#	2	2	4	5	0.5-3.8	5.5	0.7-2.0	5000	42/45 480x355x540
MS-EX5214D/UT	DCX27 14#	2	2	4	4	3.8	5.5	0.7-2.0	7500	42/45 480x355x540
MS-EX5214D	DCX27 14#	2	2	4	4	3.8	5.5	0.7-2.0	7500	42/45 480x355x540
MS-EXT5214D	DCX27 14#	2	2	4	4	3.8	5.5	0.7-2.0	7500	42/45 480x355x540
MS-EXT5214D/UT	DCX27 14#	2	2	4	4	3.8	5.5	0.7-2.0	7500	42/45 480x355x540

Model	Needles	2	3	4	5	Stitch Length	Stitch Width	Speed	Stitch Density	Dimensions
MS-GR99DT	DCX27 9#-14#	2	2	4	3-4-5	0.5-3.8	5.5	0.7-2.0	7000	30/36 515x360x560
MS-GL99BT-MF	DPX27 11#	2	2	4	5	0.5-3.8	6	0.7-2.0	7000	27/35 480x360x540
MS-GL99BT-K2	DPX27 11#	2	2	4	5	0.5-3.8	6	0.7-2.0	7000	27/35 480x360x540
MS-GL99BT-K1	DPX27 11#	2	2	4	5	0.5-3.8	6	0.7-2.0	7000	27/35 480x360x540
MS-EXT5100D	DCX27 14#	2	2	4	4	0.5-3.8	5.5	0.7-2.0	7000	42/45 455x350x475
MS-EXT3216D-LF	DCX27 14#	2	2	4	4	0.5-3.8	5.5	0.7-2.0	7000	42/45 455x350x475
MS-EXT5214D/UT-LF	DCX27 14#	2	2	4	4	0.5-3.8	5.5	0.7-2.0	7000	42/45 455x350x475

**MS-EX5102**  
双针杆床垫包缝机  
Mattress Overlock Sewing Machine (2 Needle-Bar)



- 1.Synchronous feeding structure with excellent feeding performance, even very thick fabrics can go through easily while it often failed in other types of sewing machines;
- 2.Both thick and thin fabric can be easily processed;
- 3.Automatic cooling and lubrication system;
- 4.Lubricate system did optimization more durable, high speed reach to 3500rpm;
- 5.Pneumatic pressure foot lifter,needle gauge can choose from 16mm/27mm/35mm or customization.



**MS-MO6904**  
双针杆床垫包缝机  
Mattress Overlock Sewing Machine (2 Needle-Bar)



It is used for mattress and over-thick fabrics flanging. It can also sew the non-woven fabric with mattress edge.

- 1.JUKI sewing head with double-bolts straight needle design;
- 2.Head with automatic oil supply system, lubricating each part easily;
- 3.Double-needle five-thread synchronous structure, strong gear cloth-feeding system, ensuring feeding precision and perfect seam;
- 4.Both thick and thin fabric can be easily processed;
- 5.Taiwan servo motor.

MS-EX5102	21	27	20-80	18	130	1290x680x1180					
Model	Head	Max. speed	Flanging width	Flanging thickness	Lubrication	Needle	Stitch length	Air pressure	Total power	Power	
MS-MO6904	JUKI 6900	3,000RPM	25mm	1-70mm	JUKI MACHINE OIL 18	Dox5 21#	2,3,5mm	0.5-0.8 MPa	550W	220V 1 PHASE	



**MS-GA112-1-F-P**  
包缝机三位气动吸风剪线装置(含切刀和电机)  
3 Ways Pneumatic Suction Chain Cutter Device  
With Overlock Machine (Cutter & Motor)

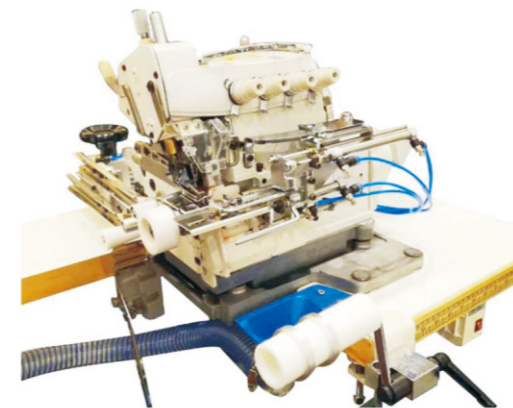

**MS-AC1360KSP**  
自动圆领衫辅助器  
Automatic Circular Collar Setter

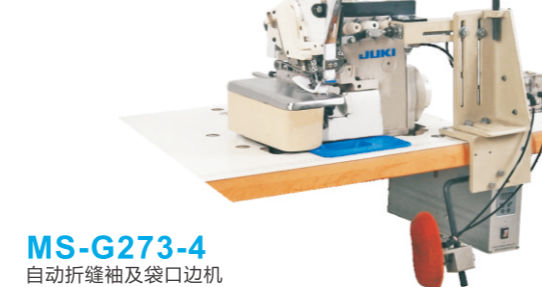
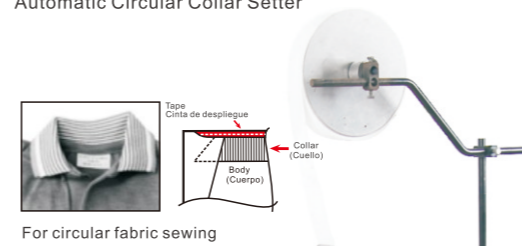

**MS-G273-4**  
自动折缝袖及袋口边机  
Semi Fashion Collar Setting And Taping



**MS-18/UT**  
微电脑18段松紧带送带&切带装置  
Microcomputer (18 Section) Elastic  
Feeding & Cutting Tape Device

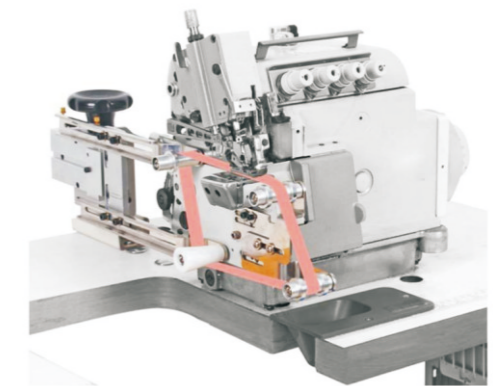

**MS-1301KSP**  
气动圆领衫辅助器  
Pneumatic Circular Collar Setter

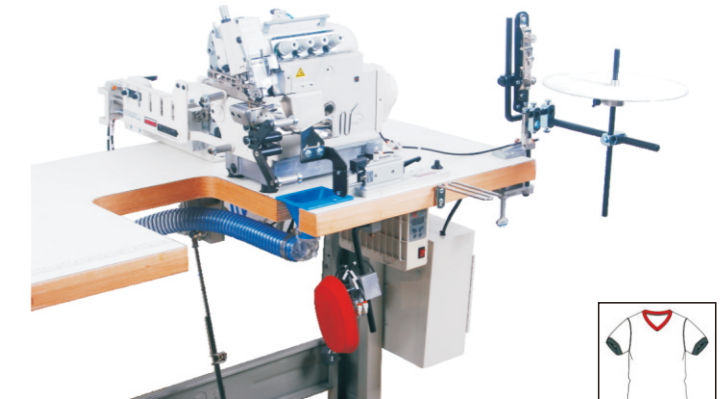

**MS-G273-37**  
半自动缝圆领&V型领口装置  
Semi-Automatic Circular Collar And Taping





# Interlock Sewing Machine Series

## 绷缝机系列

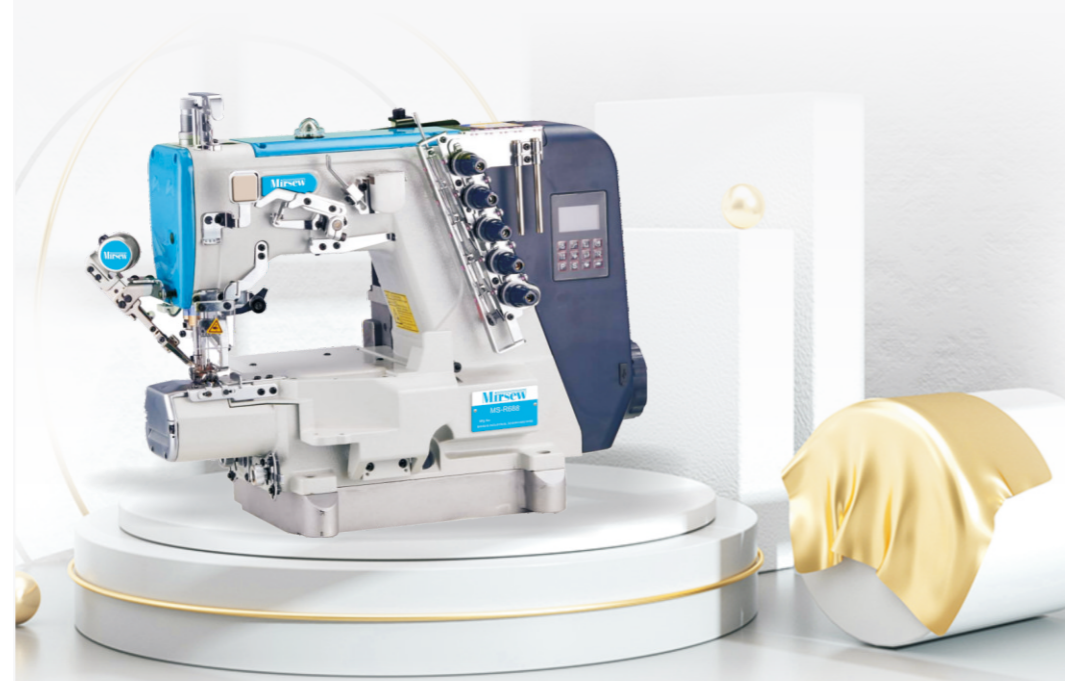

www.mirsew.com

### MS-VC2700

2, 3针筒式绷缝机  
2 Needle, 3 Needle Cylinder Interlock Sewing Machine



1. By using new materials with small friction coefficients and special processing methods, which have successfully achieved a significant reduction in the necessary oil supply for the needle bar mechanism;
2. Use oil seals on the needle bar, presser foot bar, and upper decorative line looper, and only supply the necessary minimum amount of oil to the necessary parts to recover excess oil and ensure that the oil will never leak;
3. A special oil pump is used to force oil supply from the inside of the upper shaft and the inside of the connecting rod, and because an oil film is often formed, the machine is quiet and has outstanding durability.

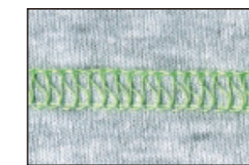

Tight Stitch



Stretch Stitch



EUT

Electric Thread Trimmer Device



UTS

Pneumatic Thread Trimming Device

### MS-R688S

双针头筒式一体绷缝机  
Double Needle Bar Cylinder Bed Interlock Sewing Machine

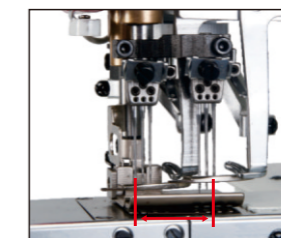

22.6mm



Double Looper

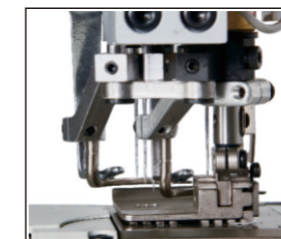

Double spreader



Option: rear puller (spreader is not available)

MS-VC2700	3(2)	5(4)	UT128GAS 11#	(4.0) 4.8 5.6 6.4	1: 0.3-1: 2.9	4.5	7.5	6000	50/57.6	660x395x630	
MS-R688S	6	10	UT128GAS 11#	5.6 6.4	0.6-1.3	4.5	5.5-7	3500	50/57.6	660x395x630	



**MS-R588**  
全智能电脑步进绷缝机  
Automatic Stepping Motor Flat Bed  
Interlock Sewing Machine



**MS-S562-SUT/ST**  
高速一体步进电脑绷缝 (面剪/拨线二选一)  
High Speed Integrated Stepping Motor  
Interlock Sewing Machine (Trimmer Or Wipper)



**MS-R688**  
全智能电脑步进筒式绷缝机  
Automatic Stepping Motor Cylinder Bed  
Interlock Sewing Machine

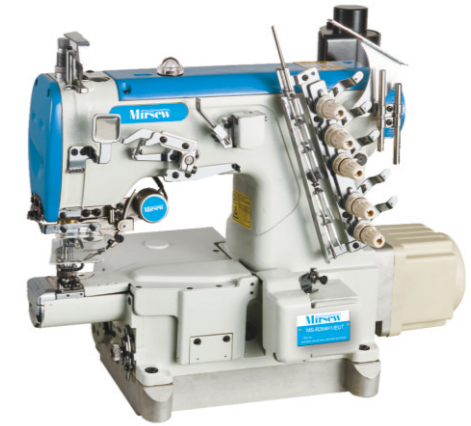

**MS-R264H1/EUT**  
细筒式电脑绷缝机  
Small Cylinder Bed Interlock Sewing  
Machine With Electronic Auto Trimmer



**MS-S562-01-EUT/WP**  
高速一体自动剪线绷缝 (面剪/拨线二选一)  
High Speed Integrated Interlock Sewing Machine With  
Electric Auto Trimmer (Trimmer Or Wipper)



**MS-S562-01DA**  
高速一体直驱绷缝  
High Speed Integrated Direct Drive  
Interlock Sewing Machine



**MS-562-01-EUT/WP**  
高速直驱自动剪线绷缝  
High Speed Direct Drive Interlock Sewing  
Machine With Electronic Auto Trimmer



**MS-600-01CB/EUT**  
高速小方头电脑绷缝机  
High Speed Direct Drive Cylinder Bed Interlock Sewing  
Machine With Electronic Auto Trimmer



**MS-600-01DA**  
高速直驱小方头绷缝机  
High Speed Direct Drive Cylinder Bed  
Interlock Sewing Machine

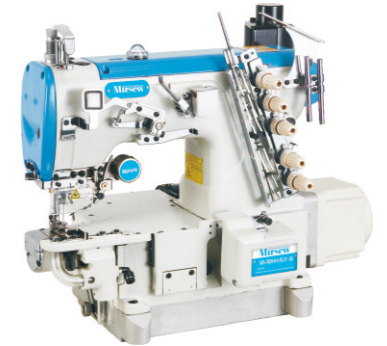

**MS-R264H1/EUT-35**  
细筒式电脑左切刀绷缝机  
Small Cylinder Bed High Speed Interlock  
With Left Hand Side Fabric Trimmer



**MS-562-02DB**  
高速直驱滚领绷缝  
High Speed Direct Drive Interlock Sewing  
Machine With Tape Binding



**MS-562-03FQD**  
高速直驱三合一绷缝 (一般缝, 滚领, 盖缝)  
High Speed Direct Drive Interlock Sewing Machine  
(General Plain Sewing, Tape Binding, Cover Seaming)



**MS-562-05DB/FT**  
高速直驱上花边松紧绷缝 (附右切刀修边装置)  
High Speed Direct Drive Interlock Elastic Or Lace  
Attaching (With Right Hand Side Fabric Trimmer)



**MS-600-02DA**  
高速筒式滚领绷缝机  
High Speed Direct Drive Cylinder Bed  
Interlock Sewing Machine (With Tape Binding)



**MS-600-33AC/PUT**  
高速气动剪线右切刀绷缝机 (带吸风筒, 后拖轮)  
High Speed Automatic Cylinder Bed Interlock With  
Right Cut (With Suction Device And Back Puller)



**MS-600-35BB/PUT**  
高速气动剪线左切刀绷缝机 (带吸风筒)  
High Speed Automatic Cylinder Bed Interlock  
With Left Cut (With Suction Device)

	3	5	UY128GAS 11#	5.6	0.5-1.3	1.5-4.4	5.5-7	5000	50/57.6	660x395x630
MS-R588	3	5	UY128GAS 11#	5.6	0.5-1.3	1.5-4.4	5.5-7	5000	50/57.6	660x395x630
MS-S562-SUT/ST	2/3	4/5	UY128GAS 11-14#	3.2,4.8,5.6,6.4	0.5-1.3	1.5-4.4	5.5	6000	45/50	610x400x530
MS-S562-01-EUT/WP	2/3	4/5	UY128GAS 11-14#	3.2,4.8,5.6,6.4	0.5-1.3	1.5-4.4	5.5	6000	45/50	610x400x530
MS-S562-01DA	2/3	4/5	UY128GAS 11-14#	3.2,4.8,5.6,6.4	0.5-1.3	1.5-4.4	5.5	6000	45/50	610x400x530
MS-562-01-EUT/WP	2/3	4/5	UY128GAS 11-14#	3.2,4.8,5.6,6.4	0.5-1.3	1.5-4.4	5.5	6000	45/50	610x400x530
MS-562-02DB	2/3	4/5	UY128GAS 11-14#	3.2,4.8,5.6,6.4	0.5-1.3	1.5-4.4	5.5	6000	45/50	610x400x530
MS-562-03FQD	2/3	4/5	UY128GAS 11-14#	3.2,4.8,5.6,6.4	0.5-1.3	1.5-4.4	5.5	6000	45/50	610x400x530
MS-562-05DB/FT	2/3	4/5	UY128GAS 11-14#	3.2,4.8,5.6,6.4	0.5-1.3	1.5-4.4	5.5	6000	45/50	610x400x530

	3	5	UY128GAS 11#	5.6	0.5-1.3	4.5	5.5-7	5000	50/57.6	660x395x630
MS-R688	3	5	UY128GAS 11#	5.6	0.5-1.3	4.5	5.5-7	5000	50/57.6	660x395x630
MS-R264H1/EUT	3	5	UY128GAS 11#	5.6	0.8-1.4	3.8	5.5-7	5000	50/55	580x380x630
MS-600-01CB/EUT	2/3	4/5	UY128GAS 11-14#	3.2,4.8,5.6,6.4	0.5-1.3	1.5-4.4	5.5	6000	50/55	610x400x530
MS-600-01DA	2/3	4/5	UY128GAS 11-14#	3.2,4.8,5.6,6.4	0.5-1.3	1.5-4.4	5.5	6000	50/55	610x400x530
MS-R264H1/EUT-35	2/3	4/5	UY128GAS 11-14#	3.2,4.8,5.6,6.4	0.5-1.3	1.5-4.4	5.5	6000	50/55	610x400x530
MS-600-02DA	2/3	4/5	UY128GAS 11-14#	3.2,4.8,5.6,6.4	0.5-1.3	1.5-4.4	5.5	6000	50/55	610x400x530
MS-600-33AC/PUT	2/3	4/5	UY128GAS 11-14#	3.2,4.8,5.6,6.4	0.5-1.3	1.5-4.4	5.5	6000	50/55	610x400x530
MS-600-35BB/PUT	2/3	4/5	UY128GAS 11-14#	3.2,4.8,5.6,6.4	0.5-1.3	1.5-4.4	5.5	6000	50/55	610x400x530

**MS-1513-356/VTS**

高速直驱筒式绷缝机  
High Speed Servo Direct Drive Cylinder Bed Interlock Sewing Machine  
(Taiwan Spare Parts & Hohsing Motor)

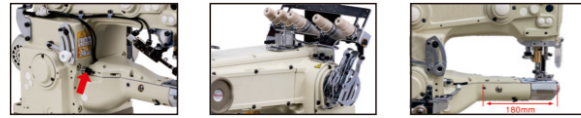

Button For Adjusting  
Stitch Length External Thread  
Take-up 180mm Cylinder  
Length



Upper Looper  
On Left Rear Needle  
Guard Differential Feed

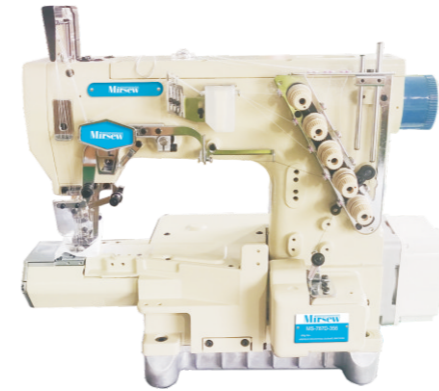

**MS-787D-356**

直驱绷缝机  
Direct Drive Cylinder Bed Interlock



**MS-787T-L600/EWT**

高速直驱左切刀绷缝机  
High Speed Direct Drive Cylinder Bed Interlock  
With Left Side Cutter

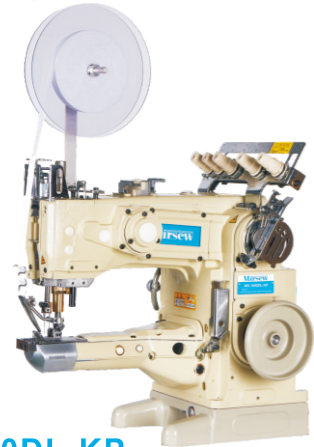

**MS-1500DL-KP**

高速伺服直驱上布条感应式切带筒式绷缝机  
High Speed Servo Direct Drive Upper Fabric Induction  
Type Cutting Device Cylinder Bed Interlock Sewing Machine



**MS-1500DL/EUT**

高速直驱自动剪线加长筒式绷缝  
Long Arm High Speed Cylinder Bed Interlock  
Sewing Machine With Auto Trimmer



**MS-787T-R600/EWT**

高速直驱右切刀绷缝机  
High Speed Direct Drive Cylinder Bed Interlock  
With Right Side Cutter

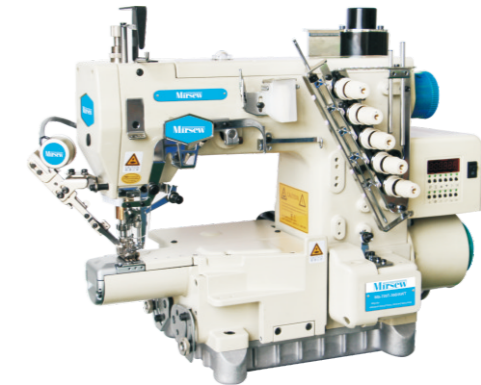

**MS-720T-356/AWT**

高速直驱气动剪线小嘴绷缝机  
High Speed Direct Drive Small Cylinder Bed Interlock  
With Pneumatic Trimmer

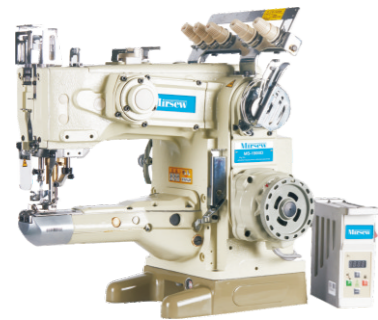

**MS-1500D**

高速直驱筒式绷缝机  
High Speed Direct Drive Cylinder Bed Interlock  
Sewing Machine

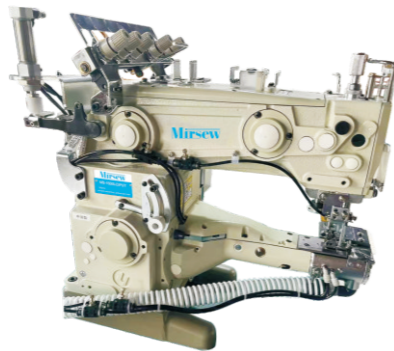

**MS-1500LC/PUT**

高速直驱气动剪线带左刀筒式绷缝机  
High Speed Direct Drive Cylinder Bed Interlock Sewing  
Machine With Pneumatic Trimmer and Left Cut

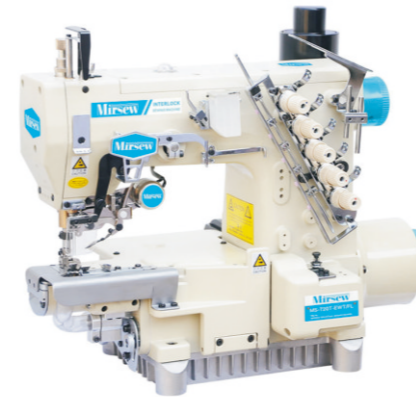

**MS-720T-EWT/L600**

高速直驱左切刀小嘴绷缝机  
High Speed Direct Drive Small Cylinder Bed Interlock  
With Left Side Cutter



**MS-720D**

高速直驱小嘴绷缝机  
High Speed Direct Drive Small Cylinder Bed Interlock

	⚙️	🔔	📏	⚡	🔪	🧵	🔄	⚖️	📦	
MS-1513-356/VTS	3(2)	5(4)	UY128GAS 9-14#	4,8,5,6	0.8-2	4.4	9	4000	42/47	430x284x360
MS-1500DL-KP	3(2)	5(4)	UY128GAS 9-14#	3,2,4,0,4,8,5,6,6,4	0.8-2	4.4	8	4000	42/47	430x284x360
MS-1500DL/EUT	3(2)	5(4)	UY128GAS 9-14#	3,2,4,0,4,8,5,6,6,4	0.8-2	4.4	8	4000	52/57	730x284x360
MS-1500D	3(2)	5(4)	UY128GAS 9-14#	3,2,4,0,4,8,5,6,6,4	0.8-2	4.4	8	4000	42/47	430x284x360
MS-1500LC/PUT	3(2)	5(4)	UY128GAS 9-14#	3,2,4,0,4,8,5,6,6,4	0.8-2	4.4	8	4000	52/57	730x284x360

	⚙️	🔔	📏	⚡	🔪	🧵	🔄	⚖️	📦
MS-730T-356/EWT(EST)	3	4/5	UY128GAS 11-14#	4,8,5,6,6,4	1.4-4.5	7	5000	42/50	635x245x565
MS-787T-L600/EWT	3	4/5	UY128GAS 11-14#	4,8,5,6,6,4	1.4-4.5	7	5000	42/50	635x245x565
MS-787T-R600/EWT	3	4/5	UY128GAS 11-14#	4,8,5,6,6,4	1.4-4.5	7	5000	42/50	635x245x565
MS-720T-356/AWT	3	4/5	UY128GAS 11-14#	4,8,5,6,6,4	1.4-4.5	7	5000	42/50	635x245x565
MS-720T-EWT/L600	3	4/5	UY128GAS 11-14#	4,8,5,6,6,4	1.4-4.5	7	5000	42/50	635x245x565
MS-720D	3	4/5	UY128GAS 11-14#	4,8,5,6,6,4	1.4-4.5	7	5000	42/50	635x245x565

**MS-62GD**

超高速系列  
Super High Speed Series

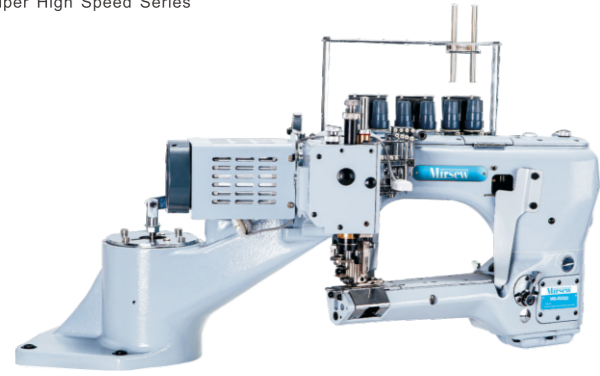

- 1.High precision cutting system, fast and efficient (optional device);
- 2.Strong suction device (optional);
- 3.All ceramic wire runner, more smoothly;
- 4.Elastic silicone "heart protection" pad, loving, more comfortable;
- 5.Integrated structure design to prevent oil seepage;
- 6.Intelligent anti-breaking device, without winding of the hitting CAM (optional);
- 7.New fully sealed tool rest design, prevent oil leakage.



**MS-S600** 双差动系列  
Double Differential Series

The micro-adjustment of dual differential feed ratio can receive a higher quality of sewn product.

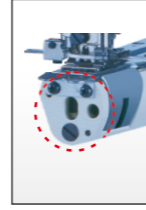

**MS-62GX** 超细嘴系列  
Super Small cylinder bed Series

125mm circumference

**MS-740H-UT**

直驱曲臂式四针六线拼缝机  
Direct Drive 4-Needle 6-Thread Feed-Off-The-Arm Flatseamer



Special shoes  
This machine improves the sewing technology for the knitted fabric of footwear, and the stitching of the knitted upper is more stable and smooth.

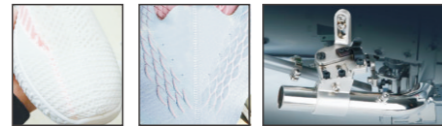

**MS-460D**

直驱立柱型四针六线拼缝机  
Direct Drive 4-Needle 6-Thread Postbed Flatseamer



1. Automatic presser foot lifter.
- 2.Postbed interlock type is easy to operate and can complete Highly difficult sewing.
- 3.Can be applied to different kinds of sewing process with different parts.
- 4.The feeding method of DU is more powerful than ordinary ways. and easier to repair and adjust.

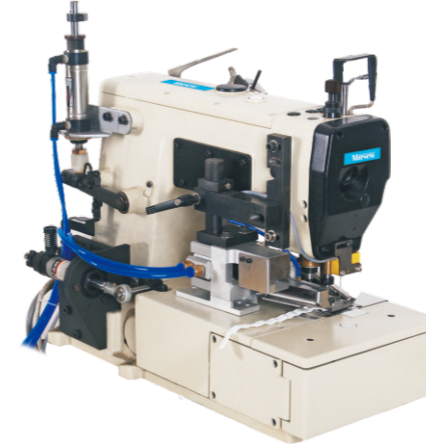

**MS-562-01DA/CTP-EC-1P**

直驱自动感应切带装置  
DD Motor Automatic Induction Tape Cutting Device  
(With Coverstitch)

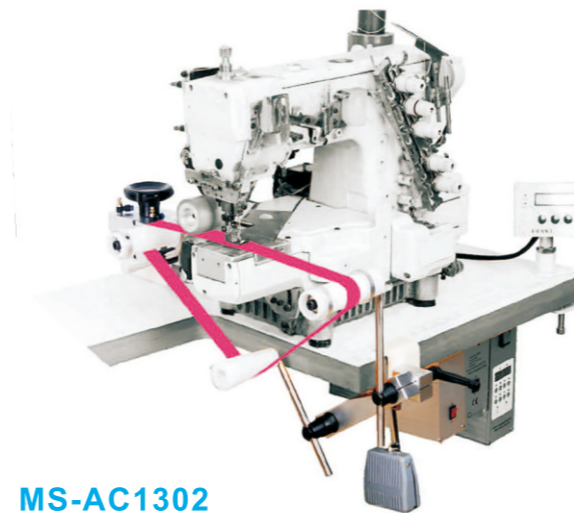

**MS-AC1302**

气动裤头滚轮辅助器  
Pneumatic Roller Tension Device

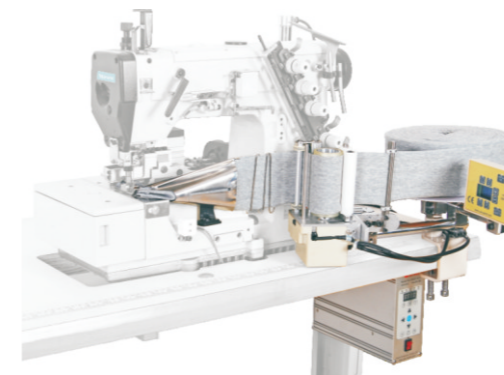

**MS-GM4S-100**

微电脑松紧带四段侧送带机  
Microcomputer Computerized Elastic Metering Device (4 Section, Side Feed Type)



**MS-600-01DA/GMD-18/UT**

微电脑18段防打结送带&切带装置  
Microcomputer Computerized With Untangling Motor Device and Cutting Tape Device (18 Section)



**MS-EC3361KP**

直驱伺服电机自动感应切带装置(咀嘴车)  
DD Servo Motor Auto Induction Tape Cutting Device  
(Cylinder-Bed Voerlock Machine)



**MS-GFS-1**

侧送型送带机 (附电机型防打结装置)  
Side Tape Feeder Machine (With Untangling Motor Device)

Model	Needles	Threads	Speed (rpm)	Presser Foot	Stitch	Needle	Thread	Stitch Length	Stitch Width	Stitch Density
MS-62GD	4	6	4200	1.6-2.5	mm	GBX118 11#	4.8,5.2,6.0,6.4	01:8 02:6	1:0.7-1:0.5	
MS-740H-UT	4	6	4200	1.6-2.5	mm	GBX118 11#	4.8,5.2,6.0,6.4	01:8 02:6	1:0.7-1:0.5	
MS-460D	4	6	2000	1.6-2.5	mm	MY1014	4	6	8	

# Zigzag Machine Series

## 曲折缝系列



### MS-2280D/2284D

单直驱高速曲折缝  
Direct Drive ZigZag Sewing Machine



High-technique, beautiful stitch, easy operation, long durability. It is an ideal sewing machine for decoration. It has different stitch designs by changing the optional cams. Suitable for sewing light and medium-heavy material of underwear, knitting, bra, trousers, gloves, shoes, caps and so on.

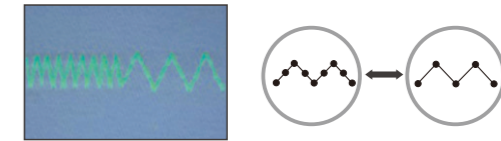

### MS-2284-7

自动剪线高速圆筒台式单针锁缝式曲折缝机  
(具有标准/3步曲折缝图案转换功能)  
Automatic Thread High Speed Cylinder Table Type Single Needle Lockstitch Zigzag Sewing Machine (With Standard/3-Step Zigzag Stitch Pattern Conversion Function)



The cylinder table zigzagging sewing machine is most suitable for the circular sewing process of tubular products such as tights, shorts and swimsuits.



### MS-2290A-SR

直驱高速电子曲折缝 (花型设计功能)  
Direct Drive High Speed Zigzag Sewing Machine (Pattern Design Function)



1. Directly driven by computer stepper motor, automatic reverse sewing function;
2. Sewing more, more complex and more beautiful patterns, increased bird's nest specifications;
3. All specifications are set to "minimum refueling type";
4. With 8 types - 14 Basic patterns, more than 300 ROM patterns, 500 stitches/1 pattern;
5. Patterns can be edited and transferred through PC (optional)/999 patterns. You can also design and make new patterns directly on the touch screen.

Name of pattern	Straight stitch	Basic zigzag	2 step zigzag	3 step zigzag	Scalloping(left)				Scalloping(right)				Blind stitch (left)	Blind stitch (right)	Custom pattern							
					Standard	Crescent	Equal-width	Equal-width	Standard	Crescent	Equal-width	Equal-width										
Stitch patterns																						
Number of stitch	1	2	4	6	24				12				24				12				2+*	maximum 500

**MS-2290A-SR-7** 2 stepper

**MS-2290A-SS-7** 1 stepper

MS-2280D/2284D	4000	—	DPX5 #10-#14	4mm	5mm	0-9mm	6/10	550	45/48	660X350X620						
MS-2284-7	4000	✓	DPX5 #10-#14	4mm	5mm	0-9mm	6/10	550	45/48	660X350X620						
MS-2290A-SR	4000	✓	DPX5 #10-#14	4mm	5mm	0-9mm	6/10	550	45/48	660X350X620						



1. This machine adopts a self-developed tangent mechanism
2. Energy-saving servo motor directly connect to the main shaft, start fast and stop accurately, reducing the response time.
3. Simple and integrated system control, the display screen is simple and generous, easy to operate
4. Equipped with automatic functions such as thread trimming, back tacking and foot lifting
5. Switch for add stitches, LED light, easier to operate /Product features



**MS-1530-7C**

单针全自动电脑曲折缝 (大梭)  
Single Needle Computerized Zigzag Sewing Machine (Large Hook)



**MS-1530D**

直驱曲折缝 (大梭)  
Direct Drive Zigzag Sewing Machine (Large Hook)



**MS-1530D-2**

双针直驱曲折缝 (大梭)  
Double Needle Direct Drive Zigzag Sewing Machine (Large Hook)

**MS-2530-7C**

直驱自动剪线上下送料曲折缝  
Top And Bottom Feed Direct Drive Zigzag Sewing Machine (Automatic trimmer)

**MS-2530D**

直驱上下送料曲折缝  
Top And Bottom Feed Direct Drive Zigzag Sewing Machine



**MS-5530DZ**

一体单直驱液晶显示屏曲折缝(大梭)  
Direct Drive Auto-Oil ZigZag Sewing Machine (Large Hook)



**MS-5530-A4**

自动加油一体直驱曲折缝 (190种花样, 可自编花样, 大梭)  
Direct Drive Auto-Oil ZigZag Sewing Machine (With 190 Patterns, External Display, Large Hook)



**MS-5530-B4**

自动加油一体直驱曲折缝 (240种花样, 可自编花样, 大梭)  
Direct Drive Auto-Oil ZigZag Sewing Machine (With 240 Patterns, External Display, Large Hook)

1. This is our independent research machine, have auto thread trimmer, auto reverse-feed and auto presser foot lifter;
2. The machine body heavier than normal machine, more stability when sewing higher speed;
3. Auto-oil makes the spare parts more durable;
4. Large hook, opening body cover easy for repairing.

MS-5530DZ: Single direct drive, without stepper motor  
MS-5530-A4: Single stepper motor with computer operation screen, 190 patterns to choose from  
MS-5530-B4: Double step, 240 patterns to choose from  
MS-5530-D4: Equipped with automatic foot lifting, automatic reverse sewing, and automatic thread cutting functions



Computer operation panel Stepper motor



**MS-5530-D4**

全自动电脑曲折缝  
Computerized Auto-Oil ZigZag Sewing Machine (Automatic Trimmer, Back Stitch, Foot Lifter)

	2500	2500	2500	2000	2000
MS-1530D	MS-1530-7C	MS-1530D-2	MS-2530-7C	MS-2530D	
2500	2500	2500	2000	2000	
DPX5	DPX5	DPX5	DPX5	DPX17	
5mm	5mm	5mm	6mm	6mm	
5mm	5mm	5mm	5mm	5mm	
0-10mm	0-10mm	0-10mm	0-10mm	0-10mm	
8/13	8/13	8/13	6/10	8/13	
550w	550w	550w	550w	550w	
29/33	31/35	29/33	35/40	33/38	
560X250X520	640X250X540	560X250X520	640X250X540	560X250X520	

	2500	2000	2000	2500
MS-5530DZ	MS-5530-A4	MS-5530-B4	MS-5530-D4	
2500	2000	2000	2500	
DPX5	DPX5	DPX5	DPX5	
5mm	5mm	5mm	5mm	
5mm	5mm	5mm	5mm	
0-10mm	0-9mm	0-9mm	0-9mm	
8/13	6/12	6/12	6/12	
550w	550w	550w	550w	
33/38	38/44	38/44	38/44	
640x250x540	580x250x510	580x250x510	580x250x510	



**MS-20U-2A**  
单步进曲折缝 (190种花样)  
Direct Drive ZigZag Sewing Machine With Single Stepping Motor (With 190 Patterns)



**MS-20U-4A**  
单步进曲折缝 (190种花样, 可自编花样)  
Direct Drive Programmable ZigZag Sewing Machine With Single Stepping Motor (With 190 Patterns)



**MS-20U-2B**  
双步进花样曲折缝 (240种花样)  
Direct Drive ZigZag Sewing Machine With Double Stepping Motor (With 240 Patterns)



**MS-1652D**  
立柱直驱曲折缝  
Direct Drive Post Bed Zigzag Sewing Machine



**MS-2652D**  
立柱直驱上下送料曲折缝  
Top And Bottom Feed Direct Drive Post Bed Zigzag Sewing Machine



**MS-20U-4B**  
双步进曲折缝 (240种花样, 可自编花样)  
Direct Drive Programmable ZigZag Sewing Machine With Double Stepping Motor (With 190 Patterns)



**MS-20U-2C**  
单步进曲折缝 (自动加油, 190种花样)  
Direct Drive ZigZag Sewing Machine With Single Stepping Motor (With 190 Patterns, Automatic Oil-Lubrication)



**MS-20U-4C**  
单步进曲折缝 (自动加油, 190种花样, 可自编花样)  
Direct Drive Programmable ZigZag Sewing Machine With Single Stepping Motor (With 190 Patterns, Automatic Oil-Lubrication)



**MS-2630DS**  
超细嘴直驱筒式上下送料曲折缝 (170mm)  
Ultra-fine Nozzle Top And Bottom Feed Direct Drive Cylinder Bed Zigzag Sewing Machine (170mm)



**MS-1630D**  
直驱筒式曲折缝  
Direct Drive Cylinder Bed Zigzag Sewing Machine



**MS-2630D**  
直驱筒式上下送料曲折缝  
Top And Bottom Feed Direct Drive Cylinder Bed Zigzag Sewing Machine



**MS-20U23D/34D**  
单直驱曲折缝 (两步三点/三步四点)  
Direct Drive ZigZag Sewing Machine (2 Step 3 Point / 3 Step 4 Point)



**MS-20U33D/43/53D/63D**  
单直驱曲折缝 (一步两点)  
Direct Drive ZigZag Sewing Machine (1 Step 2 Point)



**MS-20U93D**  
自动加油直驱曲折缝  
Direct Drive Auto-Oil ZigZag Sewing Machine



**MS-1522D**  
曲臂式直驱曲折缝  
Bending Arm Direct Drive Zigzag Sewing Machine



**MS-2522D**  
曲臂式直驱上下送料曲折缝  
Top And Bottom Feed Bending Arm Direct Drive Zigzag Sewing Machine



**MS-8530F**  
曲臂式上下送料曲折缝  
Top And Bottom Feed Bending Arm Zigzag Sewing Machine

Model	Speed (S.P.M)	Stitch	Max. Sewing Width	Max. Sewing Length	Max. Sewing Depth	Max. Sewing Thickness	Max. Sewing Density	Max. Sewing Length	Max. Sewing Width
MS-20U-2A	1800	DPX5	4mm	5mm	0-9mm	6/12	250	26/21	580X260X500
MS-20U-4A	1800	DPX5	4mm	5mm	0-9mm	6/12	250	28/23	580X260X500
MS-20U-2B	1500-2000	DPX5	4mm	5mm	0-9mm	6/12	550	28/23	580X260X500
MS-20U-4B	1500-2000	DPX5	4mm	5mm	0-9mm	6/12	550	28/23	580X260X500
MS-20U-2C	2000	DPX5	4mm	5mm	0-9mm	6/12	550	32/27	580X260X500
MS-20U-4C	2000	DPX5	4mm	5mm	0-9mm	6/12	550	32/27	580X260X500
MS-20U23D/34D	2000	DPX5	4mm	5mm	0-9mm	6/12	550	21/24	550X250X370
MS-20U33D/43/53D/63D	2000	DPX5	4mm	5mm	0-9mm	6/12	550	21/24	550X250X370
MS-20U93D	2000	DPX5	4mm	5mm	0-9mm	6/12	550	21/24	550X250X370

Model	Speed (S.P.M)	Stitch	Max. Sewing Width	Max. Sewing Length	Max. Sewing Depth	Max. Sewing Thickness	Max. Sewing Density	Max. Sewing Length	Max. Sewing Width
MS-1630D	2000	—	DPX17	6mm	5mm	0-10mm	6/10	550	36/41
MS-2630D	2000	—	DPX5	6mm	5mm	0-10mm	6/10	550	36/41
MS-2630DS	1700	✓	DPX17 #14-#22	—	—	0-8mm	9/13	550	40/52
MS-1652D	1700	✓	DPX17 #14-#22	—	—	0-8mm	9/13	550	40/52
MS-2652D	1700	✓	DPX17 #14-#22	—	—	0-8mm	9/13	550	40/52
MS-1522D	1800	✓	DPX17 #14-#24	—	—	0-10mm	9/13	550	42/53
MS-2522D	1800	✓	DPX17 #14-#24	—	—	0-10mm	9/13	550	42/53
MS-8530F	1800	—	DPX17 #14-#24	—	—	0-10mm	9/13	550	42/53



**MS-607/609**  
便携式上下送料曲折缝  
Top And Bottom Feed Zigzag Sewing Machine  
(7"9", 110V/220V)



**MS-82800-7C**  
电脑曲折缝 (三自动)  
Computerized Zigzag Sewing Machine  
(Automatic Trimmer, Back Stitch, Foot Lifter)



**MS-391**  
厚料曲折缝  
Heavy material Zigzag Sewing Machine



**MS-266-102F**  
单针/双针厚料极粗线针杆分离曲折缝  
Heavy Duty Single/Double Needle  
Zigzag Sewing Machine(Needle Bar Separation)



**MS-366-76-12HM**  
超长型极厚料曲折缝  
Zigzag Sewing Machine For Over-length  
And Extremely Thick Materials



**MS-266-102D**  
单针/双针厚料粗线上下送料曲折缝  
Top And Bottom Feed Heavy Duty Single/  
Double Needle Zigzag Sewing Machine

Model	Speed (rpm)	Stitch Length (mm)	Stitch Width (mm)	Needle	Presser Foot	Table Size (mm)	Weight (kg)
MS-82800-7C	2000	0-30mm	36	DPX134 12-19#	10-30		550w
MS-391	1700	0-10mm	33.4	65-100(9#-16#)	9		250w
MS-366-76-12HM	700	14mm(0-14)	50.8	DYX3 27#	20	760X260	550w
MS-266-102F	800	14mm(0-14)	50.8	DYX3 27#	20	320X185	550w
MS-266-102D	800	14mm(0-14)	50.8	DYX3 27#	20	320X185	550w

# Special Sewing Machine Series

## 特种机系列





**MS-1790A**  
高速电子平头锁眼机  
Electronic Straight Button Holing Sewing Machine



**MS-1790B**  
一体高速电子平头锁眼机  
Electronic Straight Button Holing Sewing Machine



**MS-1790A-12**  
高速加长平头锁眼机  
Electronic Straight Button Holing Sewing Machine (12cm)



**MS-781DF**  
步进款平头锁眼机  
Electronic Straight Button Holing Sewing Machine With Stepping Motor



**MS-781D**  
直驱款平头锁眼机  
Direct Drive Straight Button Holing Sewing Machine



**MS-580D**  
高速电脑圆头锁眼  
Electronic Eyelet Button Holing Sewing Machine



**MS-9820**  
高速电脑圆头锁眼  
Electronic Eyelet Button Holing Sewing Machine



**MS-K150**  
圆头锁眼机  
Eyelet Button Holing Sewing Machine

Model	Needle	Stitch Length	Stitch Width	Speed	Power	Dimensions	Weight					
MS-1790A	Dp×5(#11J) #11J-#14J	14	4200	550w 220v/380v								
MS-1790B	Dp×5(#11J) #11J-#14J	14	4200	550w 220v/380v								
MS-1790A-12	Dp×5(#11J) #11J-#14J	14	4200	550w 220v/380v								
MS-781DF	DPX5 (11#-14#)	12(15/32")	3600	123	83,100,110,123 152,170,190,225	22	2.5-4mm (3/32 -5/32 )	★	550w 220v/380v	63.5/70	710x345x780	
MS-781D	DPX5 (11#-14#)	12(15/32")	3600	123	83,100,110,123 152,170,190,225	22	2.5-4mm (3/32 -5/32 )	★	550w 220v/380v	63.5/70	710x345x780	
MS-580D	DOX558 NM80 - NM120	12-16	2500	550w								
MS-9820	DOX558 NM80 - NM120	12-16	2500	550w								
MS-K150	DOX558 NM80 - NM120	12-16	2500	550w								

**MS-430DH**

高速电子竖款套结机  
Electronic High Speed Bartacking Machine (Vertical)



1. Lower noise, lower vibration;
2. Adopts best quality precision parts and customized parts, the performance is more stable;
3. Adopts computer digital control system, various sewing data and parameters can be adjusted freely;
4. 430D bartacking sewing range Y<30mm, 469D bartacking sewing range Y≤60mm.

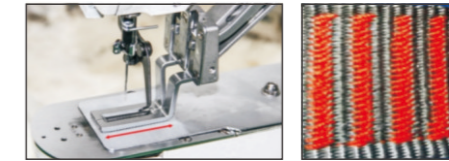

**MS-430DPE**

高速电子裤耳套结机  
Electronic High Speed Bartacking Machine For Belt Loop



1. Standard configuration with 6 different modes;
2. The most suitable number of stitches can be selected according to the size of the belt loops;
3. With unique large curved presser foot arm and presser foot structure, easier to place the fabrics;
4. The large working space is conducive to improving the production efficiency of the belt loops shaping process;
5. Application for jeans, camouflage pants, suit pants and casual pants etc.

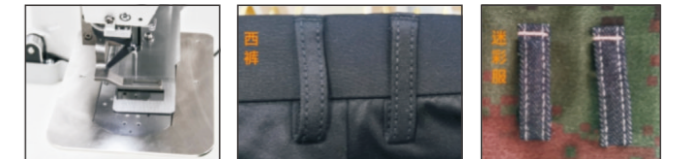

**MS-430DMO**

冲缝一体菊花眼套结机  
Electronic Punching And Bartacking Sewing Machine



1. Before sewing it, it can automatically make the hole;
2. The machine can automatically sew after checking the center of the hole;
3. Punching and sewing round eye hole can be complete in one machine, which improve the quality of sewing products and sewing production efficiency greatly;
4. This machine is application for sports garments, casual wear and all kinds of caps.

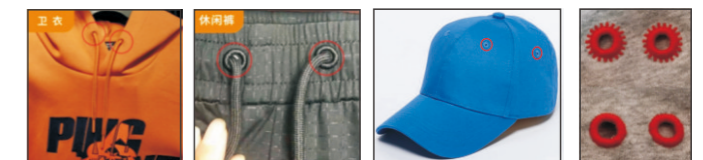

Model	Max. speed	Stitch Length	Max.No. Of Stitches	Pressure Foot Lift	Motor	Weight
MS-430DH	3200rpm	0.05-12.7mm	5000stitches/pattern	17mm	550w	58kg
MS-430DPE	3200rpm	0.05-12.7mm	5000stitches/pattern	17mm	550w	58kg
MS-430DMO	3200rpm	0.05-12.7mm	5000stitches/pattern	17mm	550w	58kg
MS-430D	3200rpm	0.05-12.7mm	5000stitches/pattern	17mm	550w	58kg
MS-469D	3200rpm	0.05-12.7mm	5000stitches/pattern	17mm	550w	58kg

**MS-1900D**

高速电子竖款套结机  
Computer Controlled High Speed Bartacking Machine



**MS-MT-2210**

自动魔术贴切缝一体机  
Automatic Cutting-Sewing Velcro Machine



1. With automatic feeding system and cutting system, which improve the production efficiency greatly;
2. By replacing the cutting die, you can sew angle rounded velcro, right-angled velcro, and oblique angle velcro.

Application



**MS-1985D**

单直驱套结机  
Direct Drive Bartacking Machine



**MS-1906D**

高速电子套结机 (5X6cm)  
Computer Controlled High Speed Bartacking Machine (5\*6cm)



**MS-430D**

高速电子套结机  
Electronic High Speed Bartacking Machine

**MS-469D**

高速电子套结机(6x9cm)  
Electronic High Speed Bartacking Machine (6\*9cm)

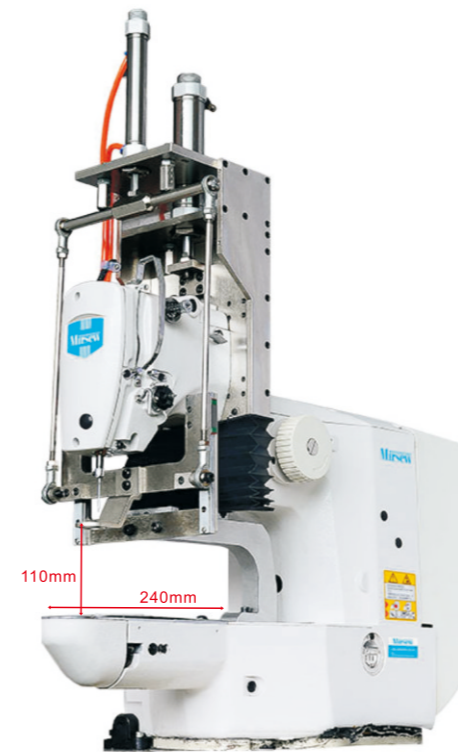

**MS-2900ASS**

高速直驱电子套结机(抱枕专用)  
Electronic Bartacking Sewing Machine (For Cushion)

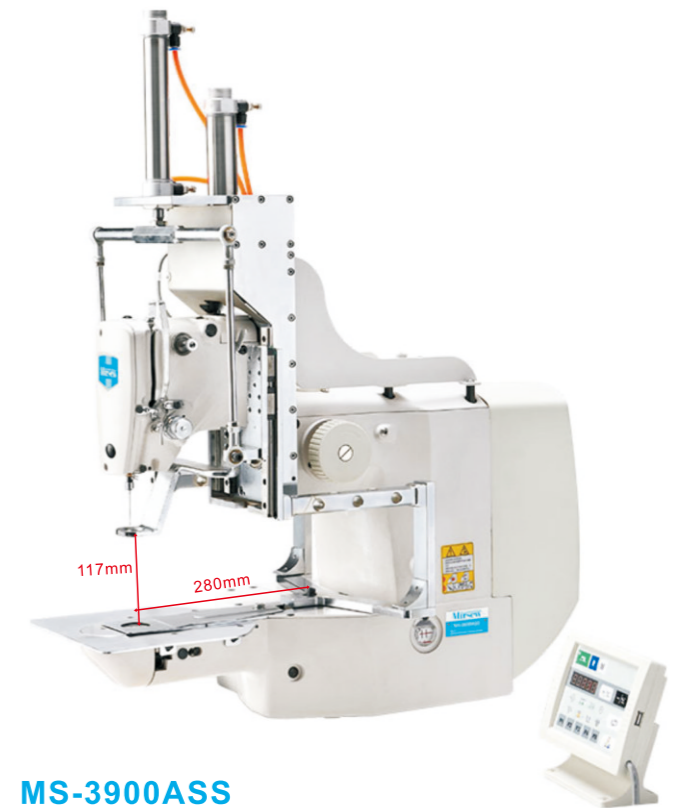

**MS-3900ASS**

高速直驱电子套结机(抱枕专用)  
Electronic Bartacking Sewing Machine (For Cushion)

Model	Needle	Max.speed	Sewing size	Pressure Foot Lift	Stitch Length	Needle bar stroke	No of standard pattern
MS-1900D	DPX5(14#)	3000rpm	30x40mm	14-17mm	0.1~10mm	41.2mm	350
MS-1985D		2000rpm		>13mm	1.5-3mm	41.2mm	
MS-1906D	DPX5(14#)	2500rpm	40x60mm	14-17mm	0.1~10mm	41.2mm	350



**MS-289**  
单线绕脚钉扣机  
Computer Controlled, High Speed, Single-Thread  
Chainstitch, Button-Neck -Wrapping Machine



**MS-438D-289**  
电脑无线暗缝钉扣机  
Computer Controlled, Blind Stitch,  
Button Attach Machine



**MS-998**  
电机款送扣装置  
Automatic Button Feeder (Motor Feed)

- Special features
1. One-click width and thickness measurement function: If different size of buttons, just press one button and put one buttons into the thickness measurement plate, adjusting the width, blocker and thickness automatically;
  2. Double functional: Two different size of buttons settled in oneprograme, size change automatically, no need manual insert easy operation, improvement of production efficiency;
  3. Function for two-hole button;
  4. Support second time thread trimming function;
  5. Anti-collision system: Operator foot on the pedal long times continue feeding button, mechanical system no collisions;
  6. One key to open the "big button" function: When sewing big buttons (button diameter 220mm), only need to open "big button ON" on the screen, and the system parameters will be adjusted automatically.



**MS-1903D**  
高速电子钉扣机  
Electronic High Speed Button Attach Machine



**MS-438D**  
高速电子钉扣机  
Electronic High Speed Button Attach Machine



**MS-998S-LK1903S**  
全自动电动送扣高速电脑钉扣机(logo识别, 颜色感应)  
Automatic Button Feeder With Electronic Button Attach Machine  
(Logo Recognition, Color Sensing)



**MS-988-LK1903**  
全自动气动送扣高速电脑钉扣机(旋转气缸)  
Automatic Button Feeder With Electronic Button  
Attach Machine (Rotary Cylinder)



**MS-373D**  
直驱高速电子钉扣机  
Direct Drive Button  
Attach Machine

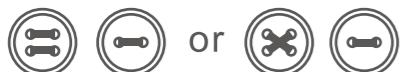

**MS-1377D**  
直驱高速电子钉扣机  
Direct Drive Button Attach Machine



**MS-988A-373D**  
经济款气动送扣高速电子钉扣机 (笔形气缸)  
Automatic Button Feeder With Direct Drive Button  
Attach Machine (Pen Cylinder)



**MS-917-1377D**  
自动送立扣高速电子钉扣机(立扣)  
Automatic Button Feeder With Direct Drive Button Attach  
Machine (Shank Button)

Voltage v	Power w	Button Sewing Speed rpm/min	Stability %	Diameter mm	Pressure mpa	Packing Size cm	Weight kg
200-240V	150	100-10000	100	8-35	0.35-0.4	65x65x45	33



**MS-K9812**  
全自动双面（电动）鸡眼机  
Automatic Double Sides Eyelet Machine



**MS-K988A**  
全自动（四合扣）柳扣机  
Automatic (Snap Fastener) Rivet Machine



**MS-8860**  
多功能打折平缝机  
Multifunctional Pleating Sewing Machine



**MS-8088**  
打折平缝机  
Pleating Sewing Machine



**MS-PK201**  
高头同步手套手指机  
Glove Post Bed Sewing Machine



**MS-808**  
大白扣  
Snap Button Machine



**MS-818D**  
伺服钉扣机  
Servo Snap Button Machine



**MS-8350/8350H**  
珠边机  
Hand Stitch Sewing Machine



**MS-8038**  
高速锁缝花边机  
High Speed Lockstitch Lace Machine



**MS-70DH**  
超声波焊接机（可定制）  
Ultrasonic Welding Machine (Customizable)



**MS-2808**  
单头气动钉扣机  
Single Head Pneumatic Button Attach Machine



**MS-3808**  
电脑三头气动钉扣机  
3-Head Pneumatic Button Attach Machine



**MS-12Q**  
12头气动拼钮机  
12-Head Pneumatic Button Attach Machine



**MS-70Q**  
超声波花边机  
Ultrasonic Lace Machine



**MS-15K**  
龙门架花边机（可定制）  
Ultrasonic Lace Machine (Customizable)



**MS-101CK**  
吹裤机  
Trousers Topper Body Press Form Finisher Blowing Machine

Model	Voltage	Power	Eccentricity	Stroke	Working pressure	Stapling frequency	Packaging Size	G.w./N. w.
MS-808	220/380v	0.37kw	19mm	38mm			560x360x340mm	24/25kg
MS-818D	220/380v	0.37kw	19mm	38mm			560x360x340mm	24/25kg
MS-2808					0.4~0.6mpa	18pic/min	440x420x270mm	26/27kg
MS-3808					0.4~0.6mpa	50pic/min	440x420x270mm	26/27kg
MS-12Q					0.4~0.6mpa	200pic/min	440x420x270mm	26/27kg
MS-K9812	220/380v	1.5kw					970x770x1730mm	210kg
MS-K988A		0.75kw				50pic/min	800x600x1300mm	162kg

Model	Power	Input Power	Output Power	Speed	Flower Film Size	Size (Lx W X H)	Work Environment	Net Weigh	
MS-8860	DBX1	1	7mm	600	4			14	
MS-8088	DBX1(70#-100#)	1	7mm	1200	5			1	
MS-8038	DBX1(11#-18#)	1			5	370	5.5-13	29.5/36.5	590x230x550
MS-PK201	46x114		0-8mm			0.5-5	12	19	485x300x525
MS-70Q	220V±5V50/60HZ 6A	1500-2500W	20KHZ	0-20M/MIN	0-100MM50-60MM	1200x560x1250mm	<25℃	105KG	



**MS-204-107H**  
电子花样机 (绳子专用)  
Electronic Pattern Sewing Machine For Ropes (12x2 CM)



**MS-204-3020H**  
单针厚料电脑花样机  
Computerized Heavy Duty Pattern Sewing Machine (30x20CM)

20x10,25x16,30x20,35x20  
45x20,50x20,50x30,60x40



**MS-G3020**  
单针电脑花样机  
Single Needle Electronic Pattern Machine

20x10,25x16,30x20,35x20  
45x20,50x20,50x30,60x40



**MS-B342/B326/B311**  
单针电脑花样机  
Single Needle Electronic Pattern Machine



**MS-204-105A**  
单双针上下送料电脑花样缝纫机  
Single/ Double Needle Top And Bottom Feed  
Heavy Duty Pattern Sewing Machine



**MS-204-370-2A**  
双针立柱式特厚料电脑花样机  
Double Needle Compound Feed Post Bed Pattern Sewing Machine  
For Extra Thick Material

13x10,22x10,30x20,35x25  
45x30,60x40,100x40



**MS-2210**  
单针电脑花样机  
Single Needle Electronic Pattern Machine



**MS-3520FL**  
机头升降电子花样机  
Head Lifting Electronic Pattern Machine



**MS-204-5020H**  
单针厚料电脑花样机  
Single Needle Heavy Duty Pattern Sewing Machine(50x20CM)



**MS-733A-3020H**  
单针特厚料花样机  
Single Needle Pattern Sewing Machine For Extra Thick Material



**MS-3520KD**  
激光开袋花样机  
Automatic Welting Machine With Laser



**MS-B326H**  
床垫拎手花样机  
Mattress Handle Strap Tacker Sewing Machine

Model	Speed (r.p.m)	Needle	Presser	Stitch	Presser Foot	Max. Sewing Speed	Max. Sewing Width	Max. Sewing Length	Max. Sewing Thickness	Max. Sewing Width	Max. Sewing Length
MS-204-107H	600	DYX3	1	1-12	56	—	✓	✓	1.5-10	140/160	1080x680x550
MS-204-3020H	800	DYX3	1	10	56	—	✓	✓	0-16	140/160	1080x680x550
MS-204-105A	800	DYX3	1	—	—	—	✓	✓	2.5	140/160	1080x680x550
MS-204-5020H	800	DYX3	1	0.9-3	25.5	—	✓	✓	2.5	140/160	1080x680x550
MS-204-370-2A	800	DYX3	1	3-6	32.4	—	✓	✓	2-4	120/130	1080x680x550
MS-733A-3020H	800	DYX3	1	—	—	—	✓	✓	1.5-10	140/160	1080x680x550

Model	Needle	Presser	Stitch	Presser Foot	Max. Sewing Speed	Max. Sewing Width	Max. Sewing Length	Max. Sewing Thickness	Max. Sewing Width	Max. Sewing Length
MS-G3020	★	2	20x10,25x16,30x20,35x20 45x20,50x20,50x30,60x40	0.05-12.7mm	★	★	30	2,700rpm	1.81 Lmin	
MS-B342/B326/B311	★	2	20x10,25x16,30x20,35x20 45x20,50x20,50x30,60x40	0.05-12.7mm	★	★	30	2,700rpm	1.81 Lmin	
MS-2210	★	2	13x10,22x10,30x20,35x25 45x30,60x40,100x40	0.05-12.7mm	★	★	30	2,700rpm	1.81 Lmin	
MS-3520FL	DPX17		13x10,22x10,30x20,35x25 45x30,60x40,100x40	0.1-12.7mm	✓	✓	120	2,500rpm		
MS-3520KD	DPX17 #18/19/20/21		13x10,22x10,30x20,35x25 45x30,60x40,100x40	0.1-12.8mm	✓	✓	20	200-2000rpm		176

**MS-ZHT-15KW**

自动滑台高周波机  
Automatic Sliding Table High-frequency Machine



1. The machine adopts relay operation control, and the left and right automatic sliding tables continuously push the mold back and forth, with precise positioning;
2. High frequency spark protection system with extremely high sensitivity to prevent damage to high frequency molds;
3. Adopting low loss European standard coaxial high-frequency resonators, the high-frequency output power is strong, which can quickly fuse the products and effectively increase production volume.



**MS-516**

打褶机  
Automatic Fabric Pleating Machine(Top Smaller Bottom Bigger)



- Computer controlled MS-516 difference.
1. It is equipped with two servo motors.
  2. Transmission by screw rod.
  3. Pleat height at two sides are regulated at random.
  4. Applicable to pleat accordion.
  5. Applicable to pleat a combination pattern of high and low.

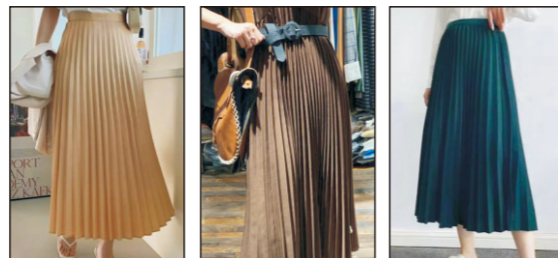

Model	Power supply	Voltage	Output power	Motor spacing	Activity itinerary	Pressurization method	Welding time	Slide size
MS-ZHT-15KW	15000W	50HZ AC380V	25KVA	200MM	150MM	Pneumatic drive	0-10 seconds	600x1100mm

Model	Max. press width	Pleat size	Motor power	Heating power	Size	Packing size	Net weight	Gross weight
MS-516	1600mm	0.8cm-4cm	1.1kW	9kw	2600*1400*1600mm	2700*1500*1800mm	800kgs	1000kgs

**MS-TSY64/94**

电脑高速有梭多针衍缝机  
Mechanical Multi-needle Quilting Machine



1. Computer layout in both Chinese and English, easy to operate.
2. The needle speed, needle pitch, pattern, etc. can be adjusted freely;
3. Adopting functions such as wire breakage detection, automatic return, and automatic repair;
4. Computer screen working status tracking and color changing display, automatic cumulative production, etc;
5. Suitable for various high-end textiles such as clothing, bedding, mattresses, sofas, sleeping bags, etc., with a wide range of uses. 360° pattern can be sewn freely.



Model	MS-TSY-64	MS-TSY-94
Dimension(LxWxH)	3600x1200x1700	4380x1200x1700
Quilting width	1700	2450
Space between needle rows	76.2、152.4	76.2、152.4
Space between needles	25.4	25.4
X-axis movement displacement	305	305
Thickness of quilting	≤20	≤20
Stitch length	2-6	2-6
Speed of production	20-180(m/h)	20-180(m/h)
Model of needle	16#/19#	16#/19#
Speed of main shaft	800(RPM)	800(RPM)
Total power required	3kw	3kw
Voltage	380V/50H 220V/60HZ	380V/50H 220V/60HZ
Gross weight	3200kg	4000kg

**MS-DF9-2628**

最高速度自动单针衍缝机  
Highest Speed Automatic Single Needle Quilting Machine

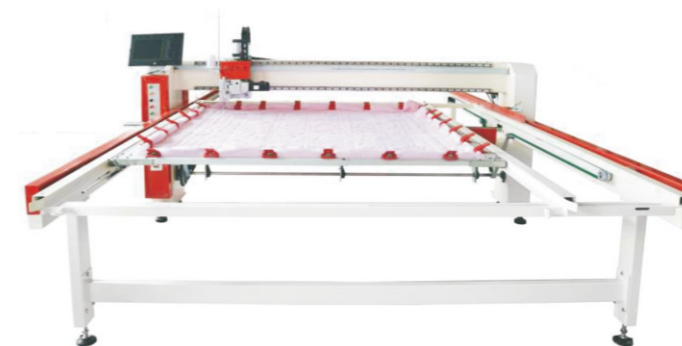

1. Direct drive high speed refueling head;
2. Head lifting and dropping down with 8cm;
3. Small noise, much quietly;
4. Windows system less problem, around 400 different design, also programmable;
5. With auto trimmer function;
6. Auto lubrication more stable and durable.

Model	MS-DF9-2426	MS-DF9-2628	MS-DF9-2830
Machine dimension	470x340x140cm	490x360x140cm	510x380x140cm
Max Quilt size	240x260cm	260x280cm	280x300cm
Quilting thick	1200g/m <sup>2</sup>		
Maximum designed speed	3500SPM		
Stitch length	Pitch 2-7mm		
Needle no	18~23# Single needle, double thread lock stitch, large hook		
Power	AC 220V 50Hz		
Power	4.5kw		
Weight	1300kg	1400kg	1500kg

**MS-CS380**  
智能穿绳机  
Automatic String Thrusting Machine



Suitable for pullover, casual pants, zipper style sweater and other flat lock Eye hole, chrysanthemum eye hole, metal roundeye rope.



**MS-004**  
打号机  
Fully Automatic Number Printing Machine



1. Applicable fabrics: Fabrics with less or no lint on the surface of the cloth; Fabric that does not adhere to adjacent pieces of fabric; Fabrics with few or no threads;
2. Applicable size: 50cm>numbered side length>7.5cm, adjacent side length>15cm;
3. Applicable thickness: The total thickness of fabric that can be accommodated in a single marking job is <4cm;
4. Number printing speed: about 75 pieces can be printed per minute;
5. Automatic ink refill: 8,000 numbers can be printed with one refill of ink;
6. Automatic dialing: You can set the numbers to be dialed on the display screen;
7. Automatic reset: Click the reset button, and the dialing wheel can quickly jump to the initial value;
8. Automatic reset: Click the reset button, and the dialing wheel can quickly jump to the initial value;
9. Voltage and pressure: 220V single phase/0.6mpa.

**MS-GJ25**  
单工位烫口袋机/口袋定型机  
Single Position Pocket Ironing Machine/Pocket Shaping Machine



It is suitable for 25cm pockets .



**MS-GJ58**  
双工位烫口袋机/口袋定型机  
Double Position Pocket Ironing Machine/Pocket Shaping Machine  
It is suitable for 58cm pocket shaping.



**MS-BK1700-22**  
全自动文胸扣缝纫机  
Automatic Bra Buckle Sewing Machine



**MS-BG-120G**  
全自动文胸钩带缝纫机  
Automatic Bra Hook & Eye Tape Sewing Machine



**MS-JD00B**  
全自动文胸肩带机  
Automatic Bra Shoulder Strap Machine

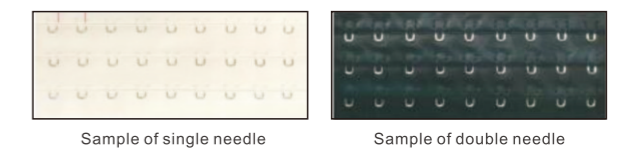

**MS-BG-120K**  
全自动文胸钩眼胶带缝纫机  
Automatic Bra Hook Eye Tape Sewing Machine

Model	Pants diameter	Cap diameter	Power	Voltage	Rated current	Weight	Packing size
MS-CS380	185-540mm	116-121mm	950w	220v	4.2A	135kg	130x57x120cm

Model	Specifications	Net weight	Gross weight	Material	Voltage	Power
MS-GJ25	55cmX50cmX38cm	38kg	45kg	Metal	220v	400w-900w
MS-GJ58	10cmX75cmX42cm	80kg	100kg	Metal	220v	900w-1800w

# Shoes and Bags Machine Series

## 鞋机箱包系列



**MS-591SD/592SD**  
 单双针步进电脑罗拉车  
 Single /Double Needle Stepping Motor  
 Computerized Compound Feed Roller Lockstitch



**MS-591XB**  
 全自动细柱款步进电脑罗拉车  
 Single /Double Needle Stepping Motor  
 Computerized Thin Column Roller Machine



**MS-552**  
 步进款全自动平台式罗拉车  
 Stepping Motor Computer Roller Sewing Machine



**MS-591KD**  
 全自动带修边步进电脑罗拉车  
 Single /Double Needle With Trimming  
 Computerized Thin Column Roller Machine



**MS-591D/592D**  
 单双针直驱电脑罗拉车  
 Single/Double Needle Computerized Post  
 Bed Compound Feed Roller Machine



**MS-591/592**  
 单双针直驱电脑罗拉车  
 Single/Double Needle Computerized Post  
 Bed Compound Feed Roller Machine

	DP	1	1-1	1-2	1-3	1-4	1-5	1-6	M	H	XH	1-7
MS-591SD/592SD	DP×5 #16	0-7	8-15	★	★	-	★	★	★	★	-	2500
MS-591XB	DP×5 #16	0-7	8-15	★	★	-	★	★	★	★	-	2500
MS-552	DP×5 #16	0-7	8-15	★	★	-	★	★	★	★	-	2500
MS-591KD	DP×5 #16	0-7	8-15	★	★	-	★	★	★	★	-	2500
MS-591D/592D	DP×5 #16	0-7	8-15	★	★	-	★	★	★	★	-	2500
MS-591/592	DP×5 #16	0-7	8-15	★	★	-	★	★	★	★	-	2500



**MS-9910D/9920D**  
单双针直驱罗拉车  
Single/Double Needle Only Direct Drive Post Bed Roller Machine



**MS-810/820**  
单双针高头车  
Single Needle/Double Needle Post Bed Sewing Machine



**MS-8365-D2**  
直驱单针高头柱车  
Direct Drive Single Needle Compound Feed Post Bed Machine



**MS-8365-2**  
双针高头柱车  
Double Needle Post Bed Machine For Shoes(443cm)



**MS-S8900-360**  
步进款360度旋转电脑高头车  
Stepping Motor 360° Rotation Post Bed Roller Machine



**MS-8900D-360**  
直驱360度旋转电脑高头车  
Direct Drive 360° Rotation Computerized Post Bed Roller Machine

**MS-Y1BX**  
细柱压缝机  
Fine Column Sewing Machine



It is suitable for pressing leather, leather material, elastic cloth, denim and other products. It is the best model for heel stitching of long women's riding boots.

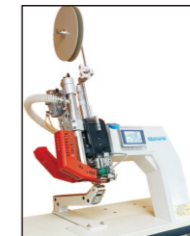
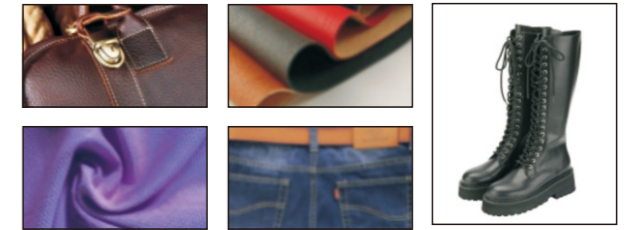

**MS-Y1B**  
Bending Arm Sewing Machine

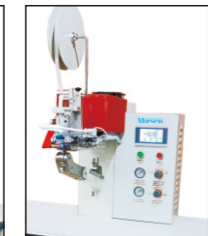

**MS-Y2BX**  
Inclined Column Sewing Machine



**MS-Y1BL**  
Upright Column Sewing Machine

**MS-Y1XH**  
细柱压条机  
Pine Column Sewing Machine



**Features**  
The machine is used for the integration of various processes such as PVC, PU, natural leather, artificial leather, and fabric material of various leather products such as shoe uppers, bags, and mobile phone cases to carry out sizing, pressure sewing and flattening. Through the operation of the machine can improve work efficiency, reduce the process, does not hurt the fabric and other advantages.  
The machine uses a computer to control the melt, the glue temperature and the glue flow, and the whole process is intelligent.  
1. It adopts hot melt adhesive to automatically sew, press-seal and flatten the integration, which can save artificial white glue, yellow glue, and oven time, and is in line with environmental protection;  
2. Use positioning electronic motor, easy operation, stable use.



**MS-Y225**  
Seam Opening And Tape Attaching Machine



**MS-Y325**  
Automatic Gluing And Laminating Machine

	DP	1	1.5	2	3	4	5	6	7	8	9	10
MS-9910D/9920D	DP×5 #16	0-7	8-15	★	★	-	★	★	★	-	2500	
MS-810/820	DP×5 #16	0-5	7-11	★	★	-	-	★	★	-	2200	
MS-8365-D2	DP×17	0-5.5	8-14	★	-	★	-	-	★	-	2000	
MS-8365-2	DP×17	0-5.5	8-14	★	-	★	-	-	★	-	2000	
MS-S8900-360	DBX17	8	15	★							2000	
MS-8900D-360	DBX17	8	15	★							2000	

Model	Power	Speed	Upper wheel lifting distance	Temperature control	Machine size
MS-Y1B	220v/50hz 3000w	0~18m/min	~18mm	≤700°	1150x570x1690mm
MS-Y1BX	220v/50hz 3000w	0~18m/min	~18mm	≤700°	1150x570x1690mm
MS-Y1BL	220v/50hz 3000w	0~18m/min	~18mm	≤700°	1150x570x1690mm
MS-Y2BX	220v/50hz 3000w	0~18m/min	~18mm	≤700°	1150x570x1690mm

**MS-350A**

花样外线机  
Pattern Outsole Sewing Machine



Suitable for sideline pattern sewing of flat-bottomed ramie sole shoes.



**MS-Y768**

缝马克线机  
Mark Sewing Machine



Features

This model professioned lockets two packet sear, do nat punch the needle point, center, close Needle stipple good, heart-gaped ring packet seam pul cover direct maldng, upper convex portion are in accordance CuSoTer 528.

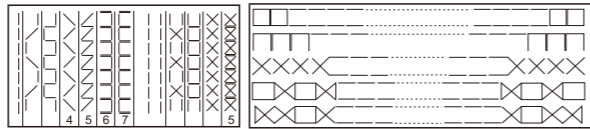

**MS-998**

立式缝内线机  
Inseam Sewing Machine



1. The machine is equipped with C/GD/K/M four type shorns. Apply to leather shoes, cloth shoes, boots bottom sole and upper penetrating sewing respectively  
2. Especially suitable for rosin cobbler's twine sewing of military footwear

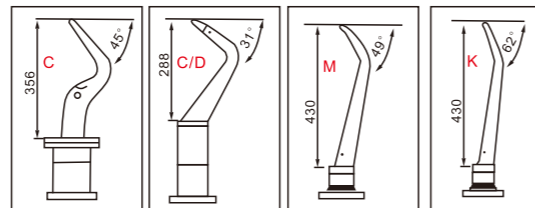

**MS-168FB**

内线机  
Double Thread Side Seam Sewing Machine

Suitable for side seam edge sewing of indoorslippers, sneakers and casual shoes.  
168/5 Gear type head, maintenance is more convenient  
1. Model SC/2 and model SD use shuttle hook, suitable for thick weave wire, the stitches are beautiful;  
2. Model SC/R and model SD/R use rotating hook, suitable for thin weave wire, with fast sewing speed



MS-168SC/2  
MS-168SC/R



MS-168SD  
MS-168SD/R



**MS-268A5**

双线座式内线机  
Double Thread Seated Type Inseam Sewing Machine

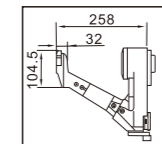

Standard horn head

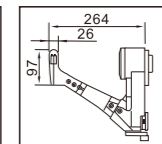

Double needle  
Double shuttle

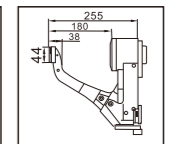

Chain stitch  
No bottom line

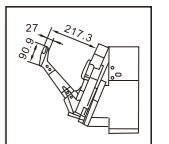

Shuttle hook  
For weaving thick thread

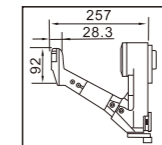

Small horn head

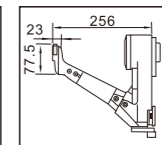

Extra small horn head

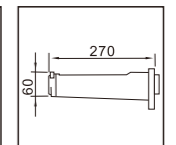

Straight arm

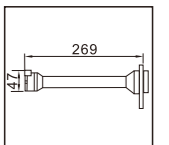

Thin straight arm

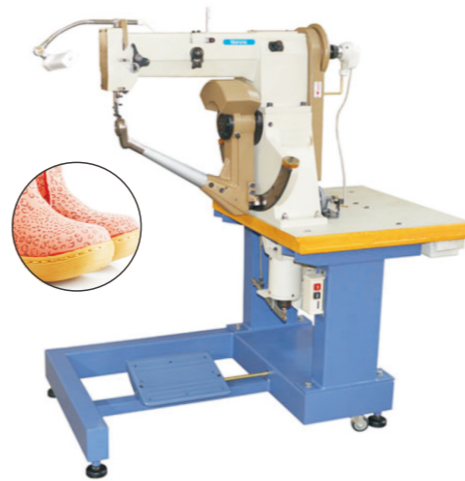

**MS-169**

双线侧缝机  
Double Thread Side Seam Sewing Machine



**MS-169FBK**

座式内线机  
Seated Type Inseam Sewing Machine



**MS-268ES**

双线座式内线机  
Double Thread Seated Type Inseam Sewing Machine



**MS-2610-2SM**

双线直驱裘皮机  
Direct Drive Fur Sewing Machine(Two Thread)

This machine is equipped with an automatic oil pump lubrication, which is easy to maintain and durable. It is an ideal choice for various sports shoes, casual shoes, upper and bottom pull-up stitching, as well as California style midsole stitching.

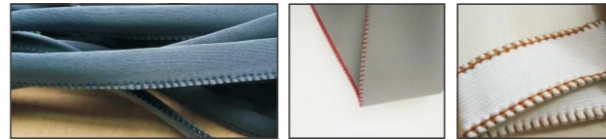

**MS-801**

削皮机  
Skiving Machine



**MS-801H**

重型削皮机  
Heavy Duty Skiving Machine



**MS-2610S-SM**

直驱绳裘皮革  
Fur Sewing Machine With Direct Drive Motor (For Binding The Cord)



**MS-2610-5SM**

直驱中薄料裘皮机  
Direct Drive Fur Sewing Machine (Thin And Middle Fur)



**MS-800-1**

自动加油中底缝合机  
Heavy Duty Lubrivation Overseaming Machine



**MS-Y101**

小型分条机  
Small Slitting Machine

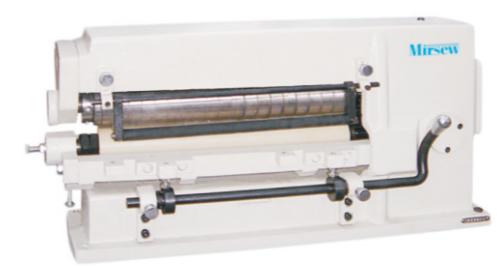

**MS-Y506**

分条机  
Slitting Machine



**MS-600D**

直驱电脑款拉帮机  
Direct Drive Computer Type Drawing Machine



**MS-202SM**

直驱婴儿鞋拉帮机  
Direct Drive Drawing Machine For Baby Shoes



**MS-2502D**

直驱地毯包边机  
Direct Drive Carpet Overedging Sewing Machine

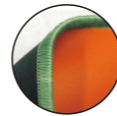

**MS-Y202**

内里成型修边机  
Inner Shaping And Trimming Machine



**MS-Y202T**

内里修边机 (下刀可调速)  
Inner Sole Trimming Machine(Knife Speed Adjustable)



Model	Size of machine	Speed	Net weight/gross weight	Packing size				
MS-2610-2SM	DPX5	8mm	2800	9mm	6/10	220v/50hz	28	420x410x350
MS-2610S-SM	DPX5	8mm	2800	9mm	6/10	220v/50hz	28	420x410x350
MS-2610-5SM	DPX5	8mm	2800	9mm	6/10	220v/50hz	28	420x410x350
MS-800-1	DPX5 14#	7mm	2800	9mm	6/10	220v/50hz	34.5	370x300x230
MS-600D	DPX5 14#	7mm	2800	9mm	6/10	220v/50hz	34.5	370x300x230
MS-202SM	DPX5 14#	7mm	2800	9mm	6/10	220v/50hz	34.5	370x300x230
MS-2502D		1-8mm	3000	12mm			38/42	

Model	Size of machine	Speed	Net weight/gross weight	Packing size	
MS-801	L530xW340xH370mm	2000rpm	40/43kg	615X415X450mm	
MS-801H	L530xW340xH370mm	2000rpm	40/43kg	615X415X450mm	
MS-Y101		1400	40~60w	16	415x175x290
MS-Y506		1400	370~550w	93.5	840x315x355
MS-Y202		4800	180~370w	26/20	560X245X485
MS-Y202T		5380	220~380V	28/26	560X245X485



**MS-Y828**  
上胶机  
Cementing Machine



**MS-Y298**  
全自动上胶折边机  
Automatic Speed Change Cementing & Folding Machine

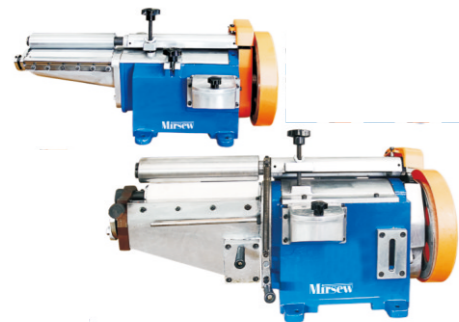

**MS-Y879**  
强力上胶机  
Cementing Machine(Power Glue)



**MS-Y150**  
大宝专用双面过胶机  
Cementing Machine



**MS-YLZ1050**  
大功率白胶喷胶机  
High-power White Glue Spraying Machine



**MS-Y829/10/13/20/30/40**  
密封式调速上胶机  
Governor Sealed Plastic Machine



**MS-Y400**  
调速过胶机  
Speed Regulating Glue Machine



**MS-2972/MS-2973**  
补鞋机  
Shoe Patcher / Repairing Sewing Machine

Model	Thickness	Speed	Power	Weight	Dimensions
MS-Y828	0~270mm	1400	220v/370w	41	1000x530x1020
MS-Y298			370w	110	1200x540x1180
MS-Y879	0~240mm		370w	56	720x460x280
MS-Y150		1500	180w	52	615x400x490
MS-Y859/12/14	120~160mm				360x290x280
MS-Y400	90~1300mm		180w	62	

**MS-B266C**  
全自动电脑圆刀削皮机  
Automatic Computerized Skiving Machine



**USE**  
This machine is suitable for edge skiving of various leather, artificial leather and rubber fabrics in leather product industry such as shoes and bags.

**CHARACTERS**

1. Adopt touch screen and PLC control to detect fault and display automatically; it's easy to operate and maintain;
2. There is no need to adjust by manual, five data sets in a group can be switched quickly.
3. Round knife speed can be setted, automatic feeding and pedal feeding can be selected, and the mode can be switched at will;
4. Equipped with a device for grinding the internal burrs of the round knife, and it is not necessary to manually grind the burrs generated by the friction between the grinding wheel and the round knife;
5. Equipped with a closed vacuum device which wind is adjustable.



Model	MS-B266C
Power	220V 50-60Hz
Power of motor	1.35kW
Package size	1200x550x1160mm
Gross weight/Net weight	175kg/135kg

**MS-300JD**  
带刀片皮机  
Band Knife Splitting Machine



**USE**  
The machine is suitable for splitting various soft and hard materials under width of 300mm and thickness of 10mm in industries such as leather, luggage, footwear, clothing, rubber, etc. to the required thickness. getting higher product quality, finer workmanship, and stronger competitiveness

**CHARACTERS**

1. Splitting thickness displayed by plc LCD, the infinitely variable adjustment of feeding, accurate number counting function;
2. With automatic feed registration device, no need to adjust cutting tool;
3. With function of dropping out when it is splitting. Adjust the clearance of pressure pad and cutting tool automatically to make the splitting precision much higher;
4. Freestanding set of dust absorbing device, automatic detection system of electronic phase.

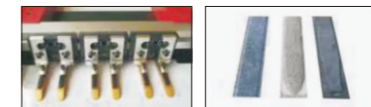

Model	MS-300JD
Max width of split	300mm
Min thickness of cutting	Adopt two feeding rollers 0.6-8mm Adopt feeding bar 0.2-8mm
Specification of band knife	2630x50x0.6mm
Power	3.5kW
Package size	1330x1130x1200mm
Gross weight/ Net weight	580kg/500kg

**MS-1209P**

智能视觉划线系统——打印款  
Double Thread Side Seam  
Sewing Machine

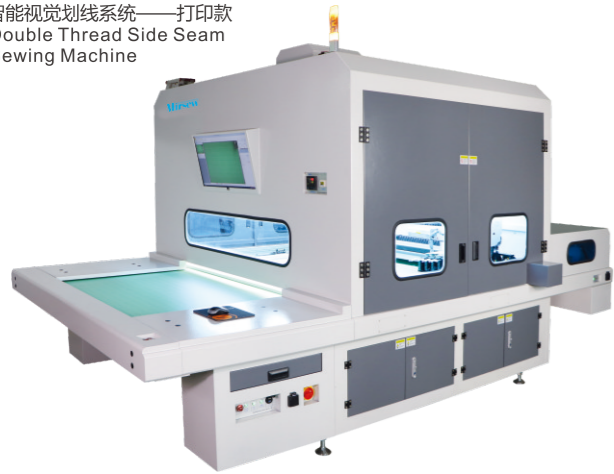

1. Adopt new industrial printheads, ore efficient for large area marking;
2. It is suitable for PU, microfiber, leather, fabric, mesh, flyweaving ect.
3. Adopt high temperature disappearing ink, fluorescent ink, ect for the customized demands of Client;
4. High-strength PVC conveyor belt and specialized high-precision servo drive roller cooperate with each other to provide power for drawing ;
5. To help execute the workflow of automatic material loading, drawing and collecting . and ensure the gun can work uninterruptedly for improving the production efficiency;
6. Specialized high strength pressed net to prevent material warping , running and deforming ect;
7. High-definition image system and intelligent recognition system always guarantee high integrity for each shape, size and color of material;
8. Recognize the shape and direction of the material , accurately locate and draw the line automatically , and can recognize more than 20 different pieces at the same time for meeting the customer's line drawing work;
9. The spray valve with built-in micron nozzle perfectly matched with imported spray valves for high precision and efficiency;
10. Run in an independent area 1200mm wide and 900mm long, Support maximize production and speed(1200mm/s);
11. Double-drive drying box speed up ink drying without waiting;
12. Intelligent stop sensing, the feeding system will stop working automatically when the system detects empty conveying and more two boards , which is convenient to finish all the collecting materials later;
13. The integrated collecting platform ensures that receiving and feeding are synchronized, one person, one machine

**MS-1209F**

智能视觉划线系统——喷墨款  
Double Thread Side Seam  
Sewing Machine



Maximum speed	1200X100MM
Working area	1200X900MM
Dimensions	4050X2350X2350MM
Pressure	0.5MPA, ≤8MPA
Voltage	AC220V
Power	7KW
Repetitive accuracy	±0.1mm
Data transmission	USB
Data format	PLT,HPGL,DXF,AX
Weight	1300KG
Receiving system	Tail end collection suction belt
Lighting function	UV lamp
Compatible ink	Fluorescent ink, water disappearing ink, never disappearing ink, oily ink, delayed disappearing ink

**MS-A600F**

磨具冲孔机  
Series Mold Punching Machine



1. High perforaiton recpision and easy change over thanks to the CNC-made moulds;
2. Servo motors ensure material feeding precision;
3. Material feeding is simply adjusted through touch screen, no mechanically adjustment;
4. Automatic paper rewinding;
5. The depth of the die punch can be easily adjusted by the handle.



Model	MS-A600	MS-A600F
Material type	Piece	Piece
Max.leather width(mm)	600	600
Max.punching speed (strokes/min)	180	180
Material thickness(mm)	0.5-3	0.5-3
Number of punchingneedles	300	300
Machine power(kw)	3P380VAC/2.2kw	3P/380VAC/2.2kw
Machine size	1.40X0.60X1.20	2.17x1.08x0.92
Wood packingsize	1.50X0.65X1.30	2.27x1.17x1.00
Machine net weight(kg)	500	850

**MS-B98**

全自动冲孔钉气眼机  
Automatic Panching & Eyeletting Machine



**MS-778-1**

压机  
Pressing Machine



**MS-HHS**

鞋头冷热定型机  
Shoe Head Cold And Hot Shaping Machine



**USE**

This machine is suitable for riveting for single-side and double-side eyelets in industries such as shoes, clothing, leather goods, paper bagsetc. The punching and riveting works are completed in one time.

**CHARACTERS**

1. Adopt intelligent control. Main motor does not start up during standby which is energy saving;
2. Punching and riveting are completed in the same station one after another, which is fast and accurate and greatly improves yield;
3. Die and riveting molds are made of imported high-strength alloy material which is not easy to wear;
4. Laser positioning makes riveting easier;
5. Design of emergency shutdown system provides best safety protection for machine overhaul and maintenance.

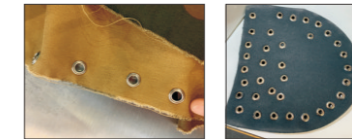

This machine is suitable for pressure fixing of casual footwear and sole bonding. Features

1. The opening and closing of the lid is controlled by pneumatic, making the work easy and efficient;
2. Photoelectric induction device to prevent no-load startup Upside-down air bag pressure, manual or automatic, two options;



**USE**

Suitable for pre-soft shaping of general toe caps, shaping of everted shoes or Hong Kong treasure shaping of various materials.

**MAIN FEATURE**

1. Suitable for shaping the toes of men's shoes, women's shoes and children's shoes. It can be applied to the method of pulling the top, pre-shaping the front toe, hand sewing method and general eversion shoe method;
2. The flat shoe upper diameter can be processed into a three-dimensional toe shape, and then other operations such as pulling the upper, front upper or eversion can be performed, which can save the upper materials and shoemaking costs;
3. The refrigeration system uses closed antifreeze liquid circulation cooling, the toe shaping speed is fast, and the refrigeration effect of the shoe mold is evenly distributed, resulting in a better and more stable shaping effect;
4. Equipped with an air-hydraulic positioning system, the pull-down speed can be adjusted and the pull-down stroke can be accurately calculated. The height of the toe side wall is consistent, simplifying the shaping technology, making the toe shape consistent and of better quality;
5. The hot mold is equipped with a steam system, which reduces the loss rate of setting the shape of genuine leather shoes, and the heating speed is faster than that of a general non steam system, and there will be no problems affecting the progress;
6. The mold is equipped with positioning adjustment, which can be adjusted arbitrarily according to the thickness of the shoe upper. It will not crush the shoe upper and can adapt to various shoe types.

Model	Voltage	Power	Gas source	Production	Weight	Size
MS-B98	220V 50HZ	0.6kw		120times/min	280KG	1000x605x1530MM
MS-778-1	220V		0.3-0.6Mpa		142KG	460x850x1260MM
MS-HHS	220V 50HZ	2.7kw	0.6Mpa	1500~1800 pairs/8 hours	560KG	1450x900x2000MM

# Multi-needle Sewing Machine Series

## 多针机系列

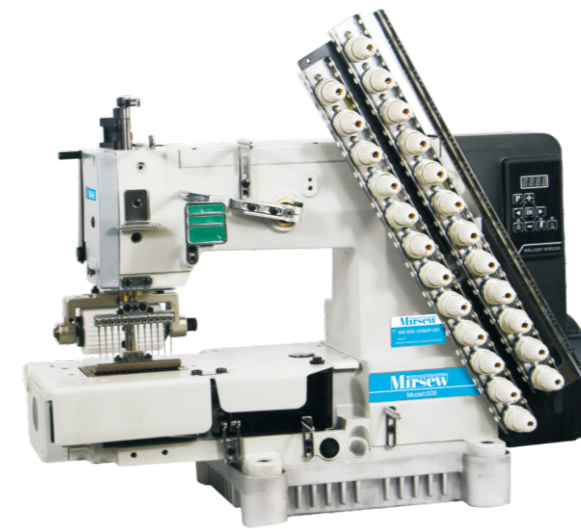
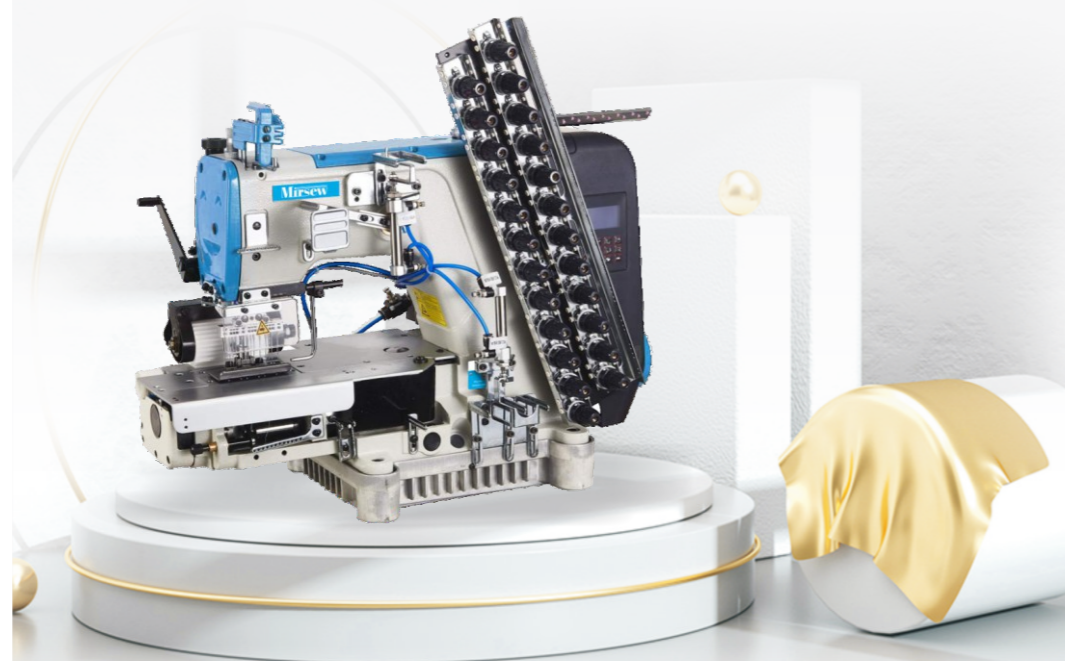

### MS-008-12064P-DD series

一体十二针半筒型双重环链式多针机  
12 Needle, Cylinder Bed, Double Chainstitch Machine

The 008 series is a cylinder bed multi-needles machines, with back and forth loopers driving mechanism, with 4-71 needle for your choice, suitable for decorative sewing on high quality dress or tubular goods. Application for: elastic, placket, rolling tape, waist, decoration, underwear, sportswear, indoor decoration.

#### CODE PARSING 代码解析

# MS-008-12064 P - UTC - AT-D

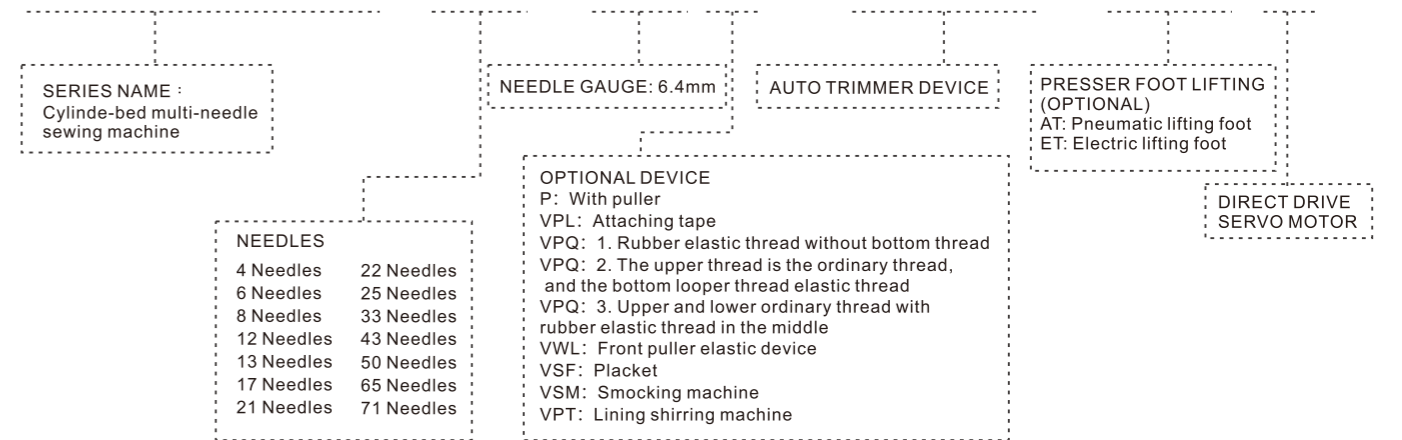

#### Device/Sample Cloth

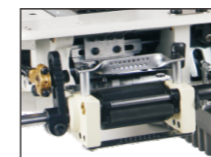

VWL: Front puller elastic device

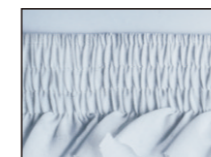

VPL: Attaching tape

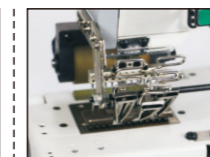

VSM: Smocking machine

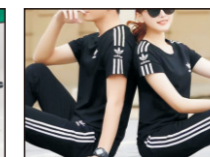

VPQ: 1 rubber elastic thread without bottom thread

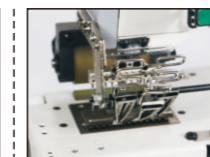

VSQ-PQ: 2 The upper thread is the ordinary thread, and the bottom looper thread elastic thread

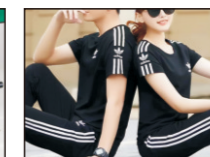

VSC-PQ: 3 Upper and lower ordinary thread with rubber elastic thread in the middle

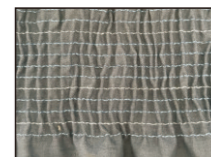
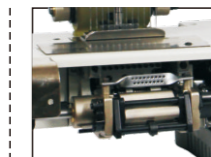
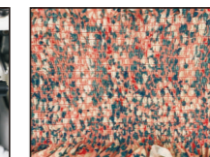
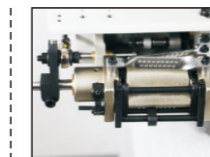

CODE PARSING 代码解析

**MS - 1 4 1 2 P - U T C - D - A T**

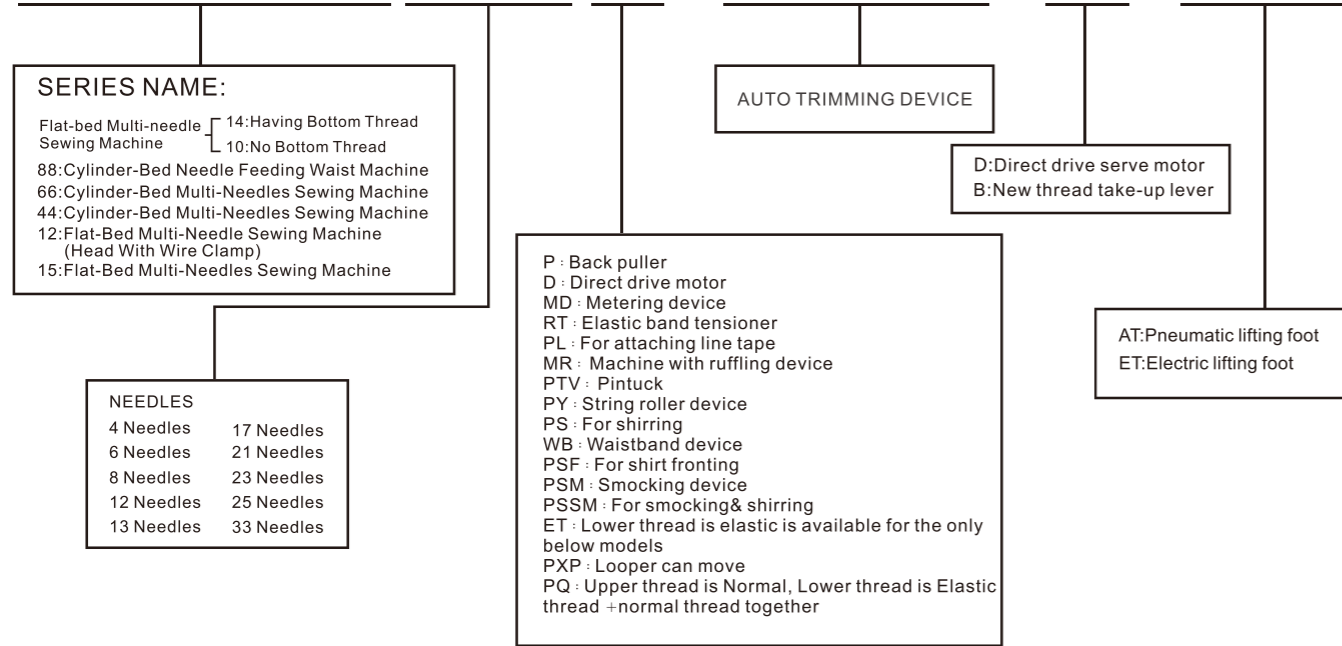

**MS-1404P-T**  
 一体四针平台型钩针纵向双重环链式多针机  
 4 Needle, Flatbed, Double Chainstitch Machine  
 With Vertical Loper Movement Mechanism



**MS-1412PSSM**  
 十二针平台型双重环链式打褶打揽缝纫机  
 12 Needle, Flatbed, Double Chainstitch  
 For Shirring And Smocking



**MS-1404PMD**  
 四针前松紧带松布装置平台型钩针纵向双重环链式裤头车  
 4 Needle, Flatbed, Double Chainstitch Machine  
 With Metering Device For Waistband



**MS-1408PL-D**  
 直驱八针平台型双重环链式贴条机  
 Direct Drive 8 Needle, Flatbed, Double  
 Chainstitch Machine For Attaching Line Tapes

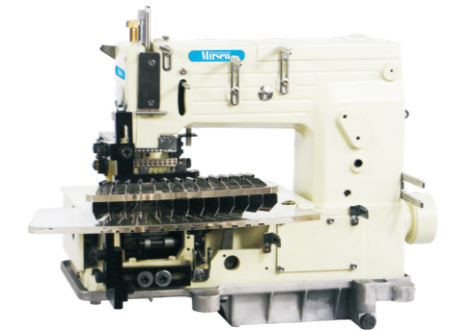

**MS-1412PTV**  
 十二针平台型双重环链式打褶缝纫机  
 12 Needle, Flatbed, Double Chainstitch Machine  
 For Pin-tucking

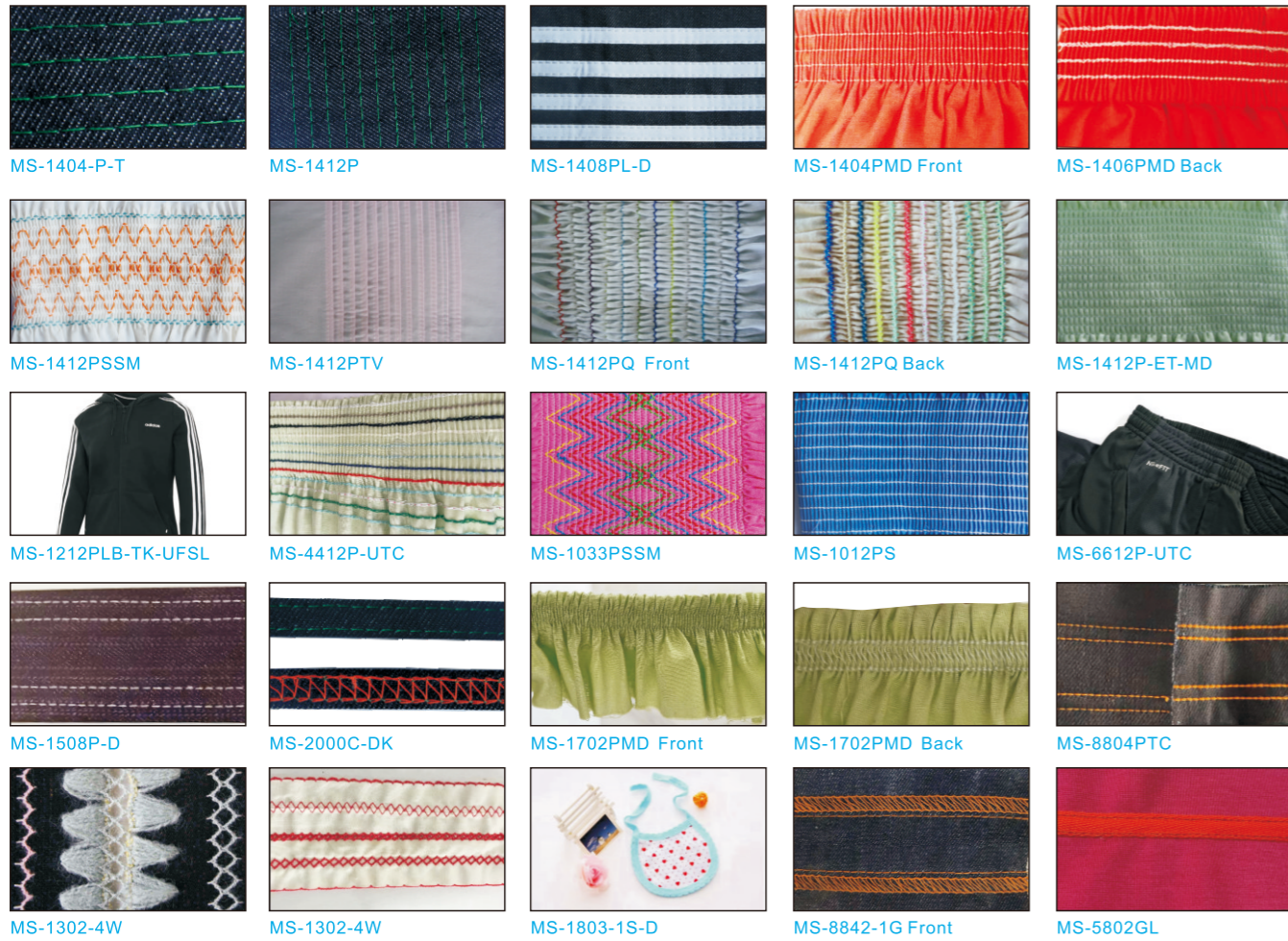

**MS-1012PS**  
 十二针平台型单环链式打皱缝纫机  
 12 Needle, Flatbed Single Chainstitch  
 Machine For Shirring



**MS-1412PQ**  
 十二针平台型缝纫机  
 12 Needle, Flatbed, Double Chainstitch  
 Machine For Simultaneous Shirring



**MS-1433P-ET-MD**  
 三十三针平台型钩针纵向双重环链式多针机  
 (上线为普通线, 下线为橡筋线)  
 33 Needle, Flatbed, Double Chainstitch Machine  
 With Vertical Loper Movement Mechanism

Model	Needles	Max. Width (mm)	Max. Length (mm)	Max. Needle Spacing (mm)	Max. Needle Size	Max. Sewing Speed (rpm)	Max. Sewing Width (mm)	Max. Sewing Depth (mm)	Max. Sewing Length (mm)
MS-1404P-T	4	113	90	1/4, 1/3, 3/8, 5/16	7-17	10	3800	44/48	600x395x600
MS-1412PSSM	12	113	90	1/4, 3/16	7-17	10	2000	52/55	600x400x600
MS-1404PMD	4	113	90	1/4, 1/3, 3/8, 5/16	8-14	10	3800	48/52	600x395x600
MS-1408PL-D	8	113	90	1/4	7-17	10	3800	48/52	600x395x600
MS-1412PTV	12	113	90	1/4, 3/16	7-17	10	3500	52/55	600x400x600
MS-1012PS	12	113	110	1/4, 3/16	7-17	10	3500	52/55	600x395x600
MS-1412PQ	12	113	90	1/4, 3/16	7-17	10	2500	52/55	590x395x600
MS-1433P-ET-MD	33	113	90	3/16	7-17	10	2500	60/65	700x480x550



**MS-1033PSSM**  
三十三针平台型单环链式打揽机  
33 Needle, Flatbed Single Chainstitch Machine For Shirring

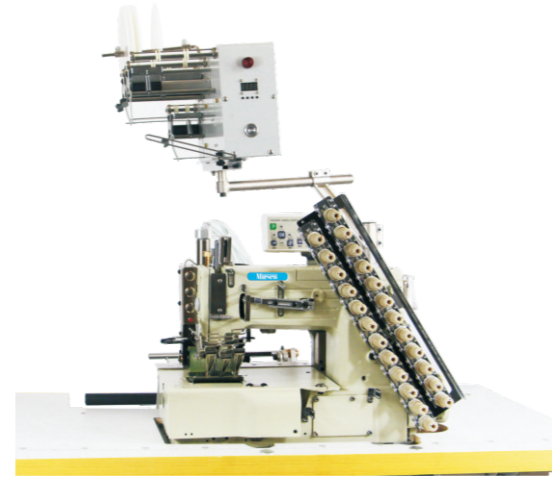

**MS-1212PLB-TK-UFSL**  
十二针平台型钩针纵向双重环链式多针机  
12 Needle, Flatbed, Looper Longitudinal Double Chainstitch Sewing Machine (With Upper Tape Feeder Device)



**MS-2000C-DK**  
双针带后切刀平台型弯针横向双重环缝带刀裤耳机  
2 Needle, Flatbed, Making Belt Loop Machine With Front Fabric Trimmer And Back Belt Cutting Device

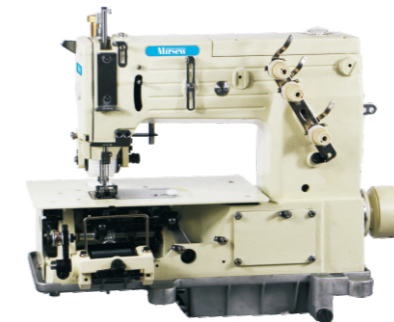

**MS-1702PMD**  
双针裤耳机 (带送松紧带装置)  
2 Needle, Flatbed, Bottom Cover Stitch Machine With Rear Puller And Metering Device For Attaching Elastic



**MS-1302-4W**  
单/双针平台型双重环缝曲牙机  
Single/Double Needle, Double Chainstitch 4 Point Zig-zag Machine

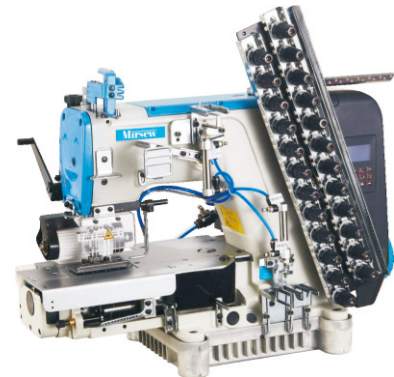

**MS-R008-UTC**  
电脑一体多针机  
Automatic Multiple Chainstitch Machine



**MS-4412P-UTC**  
十二针半筒型直驱自动剪线链式多针机  
Direct Drive 12 Needle, Cylinder Bed, Double Chainstitch Machine With Thread Trimmer

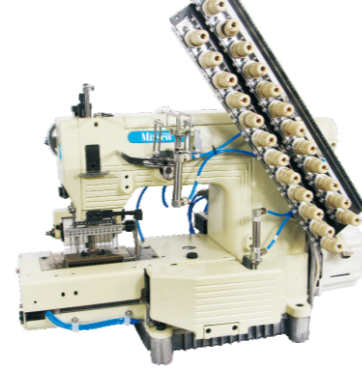

**MS-6612P-UTC**  
电脑直驱十二针半筒型同步带自动剪线多针机  
Computer Direct Drive 12 Needle Cylinder Bed Timing Belt Machine With Auto Thread Trimming



**MS-1803-1S-D**  
直驱三针五线内曲牙 (推波机) 装饰用花边机  
Direct Drive 3 Needle Picot Stitch Sewing Machine



**MS-8842-1G**  
三针上面装饰缝袋兜用缝纫机  
3 Needle Upper Decorative Sewing Pocket Sewing Machine



**MS-5802GL**  
两针平台型双重环贴袋滚领缝切机  
2 Needle, Flatbed, Double Chainstitch, Rolling Tape Collar Sewing Machine



**MS-1508P**  
四针牛仔上腰缝切机  
4 Needle, Flatbed, Double Chainstitch Machine With Puller For Waistband



**MS-1508PR**  
四针牛仔上腰缝切机装有左右分段式下拖轮  
4 Needle, Flatbed, Double Chainstitch Machine With Independent Lower Puller For Waistband



**MS-8804PTC**  
直驱四针厚料针杆送布牛仔上腰机  
Direct Drive 4 Needle Thick Material Needle Bar Feeding Jeans Waist Machine



**MS-1503PTF-FX**  
三针平台型厚料左向多针机 (反向)  
3 Needle, Flatbed, Thick Material, Left Hand Machine (Reverse Direction)



**MS-1404P-FX**  
四针平台型左向多针机 (反向)  
4 Needle, Flatbed, Left Hand Machine (Reverse Direction)



**MS-1412P-FX**  
十二针平台型左向多针机 (反向)  
12 Needle, Flatbed, Left Hand Machine (Reverse Direction)

Model	Needles	Needle Size	Needle Spacing	Needle Type	Presser Foot	Presser Foot Size	Speed (rpm)	Stitch Length (mm)	Stitch Width (mm)	Dimensions (mm)
MS-1033PSSM	DVX57 18	DVX57 110	33	33	3/16	7-17	10	2000	60/65	600x395x600
MS-1212P	UOX113 14	UYX113 90	12	24	1/4	7-17	10	3800	48/52	700x480x550
MS-R008-UTC	UOX113 14	UYX113 90	12	24	1/4	7-17	10	4000	52/55	650x400x600
MS-4412P-UTC	DVX57 14	DVX57 90	12	24	1/4	7-17	8	4000	52/55	650x450x660
MS-6612P-UTC	DVX57 14	DVX57 90	12	24	1/4	7-17	8	4000	52/55	650x450x660
MS-1508P-D	TVX5 21	TVX5 130	4	8	1/4	7-16	10	3800	44/48	600x395x600
MS-1508PR	TVX5 21	TVX5 130	4	8	1/4-1-1/4	7-16	10	3800	44/48	600x395x600
MS-8804PTC	DVX57 21	DVX57 130	4	8	1/4-1-1/4, 1/4-1/8-1/4, 3/16-1-3/16	4-12	9	4000	55/58	650x480x650

Model	Needles	Needle Size	Needle Spacing	Needle Type	Presser Foot	Presser Foot Size	Speed (rpm)	Stitch Length (mm)	Stitch Width (mm)	Dimensions (mm)
MS-2000C-DK	UYX128GAS 16	UYX128GAS 100	2	4	1/4	9-12	8	3800	44/48	600x395x600
MS-1702PMD	UYX128GAS 16	UYX128GAS 100	2	4	1/4	9-12	8	3800	44/48	600x395x600
MS-1302-4W	UOX163 11	UYX163GAS 75	2	4	3.5	8	8	3000	44/48	600x395x600
MS-1803-1S-D	UYX128GAS 14	UYX118GAS 90	3	5	3.5X4	7-16	8	3000	44/48	600x395x600
MS-8842-1G	UYX128GAS 16	UYX128GAS 100	3	7	2.4X6.4	7-16	4.5	5000	48/52	600x395x600
MS-5802GL	UYX128GAS 16	UYX128GAS 100	2	4	1/4	8-16	8	5000	48/52	600x395x600
MS-1503PTF-FX	TVX5 21	TVX5 130	3	6	1/4	7-16	10	3800	44/48	600x395x600
MS-1404P-FX	UYX128GAS 14	UYX118GAS 90	4	8	1/4	7-16	10	3800	44/48	600x395x600
MS-1412P-FX	UYX128GAS 14	UYX118GAS 90	12	24	1/4, 3/16, 1/8	7-16	10	3800	44/48	600x395x600

Embroidery  
Machine Series  
绣花机系列



**MS-1201CT**

龙门架款单头电脑绣花机  
Single Head 12 Needle Embroidery Machine (Gantry)



Powerful and versatile, suitable for processing embroidery on various fabrics. This machine is a gantry single head embroidery machine. H shape model, a variety of shapes for customers to choose.

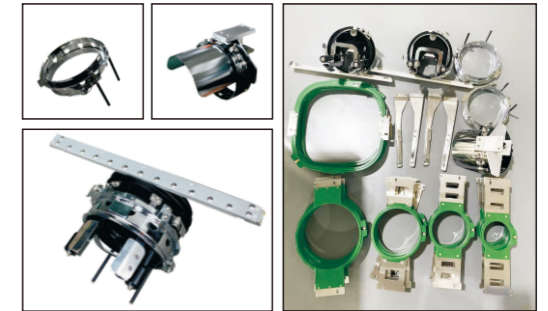

**MS-1201CT**

马头款单头电脑绣花机  
Single Head Embroidery Machine



Cap Embroidery



Finished Garments Embroidery



Flat Embroidery



Model	Computer	Embroidery Area	Needle Number	Max Speed
MS-1201CT	DA HAO	500X1200MM(Can be customized)	9/12/15	1200rpm

**MS-1201mini**  
桌上迷你多功能电脑绣花机  
Light Embroidery 12/9 Needles



1. Display resolution: 1280\*800
2. computer: dahao A15
3. 270 degree Wide cap frame
4. Suitable for cap embroidery and finished garments embroidery like T-shirt
5. Maximum number of stitches: 5 million needles
6. Number of pattern: 500pcs
7. Memory pattern capacity: 200 million needles
8. Electricity: 110V/60Hz or 220V/50Hz
9. Import pattern: USB
10. Embroidery can preview the pattern and embroidery track, and can display the running process of stitch in real time
11. Support multiple languages : Chinese, English, Arabic, Turkish, Spanish, Russian, Portuguese, French, Thai, Dutch, German, Italian, Polish, Korean, Japanese

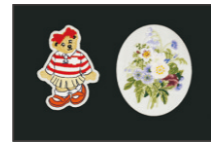

Finished Garments Embroidery



Cap Embroidery

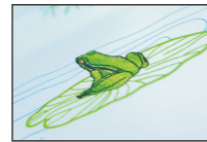

Flat Embroidery



**MS-1201FC**  
单头绣花机 (平绣及毛巾绣)  
Embroidery Machine Mix Head (Flat + Towel)



**MS-1201F+SC**  
单头平绣加盘带绣花机  
Embroidery Machine Mix Head (Flat + Cording)



**MS-1202CT**  
2头高速电脑绣花机  
Two Heads Embroidery Machine



**MS-1203CT**  
3头高速电脑绣花机  
Three Heads Embroidery Machine



**MS-1204CT**  
4头高速电脑绣花机  
Four Heads Embroidery Machine



**MS-1206CT**  
6头高速多功能电脑绣花机  
Six Heads Embroidery Machine

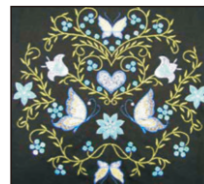

Model	Needles	Head	Working area	Max Speed	Computer	Package size	Gross weight
MS-0901Mini	9 needle	1 head	20x30cm	1000RPM	DAHAOA15	wooden case 65*57.5*76.5cm	50KG
MS-1201Mini	12needle	1 head	20x30cm	1000RPM	DAHAOA15	wooden case 65*57.5*76.5cm	50KG
MS-1501Mini	15 needle	1head	20x30cm	1000RPM	DAHAO A15	wooden case 65*57.5*76.5cm	50KG

Model	Needles	Heads	Gw.(kg)	Emb.area(mm)	Meas(mm)
MS-1202CT	12/15	2	350	400X500	1410X1110X960
MS-1203CT	12/15	3	450	400X400	1740X1140X980
MS-1204CT	12/15	4	600	400X400	2230X1030X980
MS-1206CT	12/15	6	400	400X450	3400X1300X1500

**MS-1208CT**  
8头高速多功能电脑绣花机  
Eight Heads Embroidery Machine

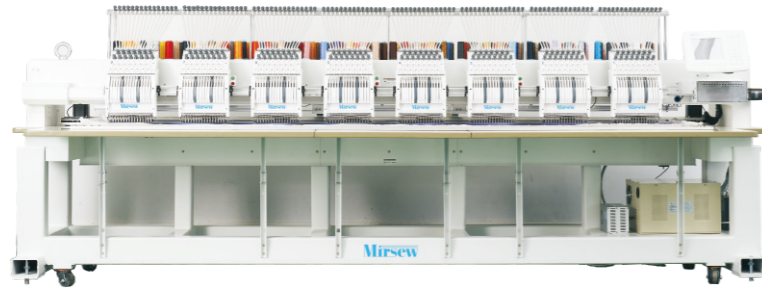

1. Suitable for embroidery on flats, caps, finished garments, arts and more;
2. Free changing between garments frame and cap frame, easy to operate;
3. Finished garment embroidery speed up to.
4. 1200rpm, cap embroidery 600rpm;
5. 270° wide angle cap system;
6. Convenient power failure recovery embroidery function, prevent embroidery half-way off cause misalignment;
7. Full screen preview design trace capable.
8. Auto start and color change, maximum 250 times color change supported;
9. Thread break detection and prevention, prevent from thread broken;
10. Chinese, English, Spanish, Turkish, Arabic and other many kinds of language well supported.

**MS-1210CT**  
10头高速多功能电脑绣花机  
Ten Heads Embroidery Machine



**MS-1212CT**  
12头高速多功能绣花机  
Twelve Heads Embroidery Machine



**MS-1121ZS**  
万向锁式手摇曲折缝绣花机  
Handle Operated LockStitch Zigzag Embroidery Machine



**MS-10-2**  
万向链式手摇绣花机  
Five Kinds Of Stitches (Chain Stitch & Towel & Taping & Winding & Radiate Stitch)



**MS-10-5**  
三针万向链式手摇绣花机  
Three Needle Handle Operated Chainstitch Embroidery Machine



**MS-10-1**  
万向链式手摇绣花机  
Upper Chainstitch Embroidery Machine(Towe And Chainstitch)



**MS-10-3**  
万向链式手摇绣花机  
Three Kinds Of Stitches (Chain Stitch & Towel & Taping)



**MS-20-1**  
万向链式长臂手摇绣花机60cm  
Handle Operated Chainstitch Embroidery Machine (Long Arm 60MM)



Model	Needles	Heads	Gw.(kg)	Emb.area(mm)	Meas(mm)
MS-1208CT	12/15	8	400	400X450	4300X1300X1500
MS-1210CT	12/15	10	400	400X450	5200X1300X1500
MS-1212CT	12/15	12	400	400X450	6000X1300X1500

Model	Needles	S.p.m	Stitch	Meas(mm)	Weight	Power
MS-10-1	14	800	5	137x1,137x1SM	21/19	535x405x305mm 4P;250W
MS-10-2	14	800	7	CEx3/PHxC70	29/26	580x545x330mm 4P;250W
MS-10-3	14	800	5	137xTR137x1SM	21/19	535x405x305mm 4P;250W
MS-10-5	14	800	5	137x1,137x1SM	22/20	535x405x305mm 4P;250W

# Blind Stitch/ Flat Seaming Machine Series

## 暗缝/麦夹机系列



www.mirsew.com



**MS-361-BD**  
厚料背置伺服驱动暗缝机  
Blind Stitch Sewing Machine For Heavy  
Duty Materials (Back-located Drive Motor)



**MS-364QBD3**  
前后差动气动三自动暗缝机  
Computerized Differential Pneumatic  
Blind Stitch Sewing Machine



**MS-370BD**  
裤耳背置伺服驱动暗缝机 (裤耳幅宽可调)  
Trousers Ears Blind Stitch Sewing Machine With  
Back-located Drive Motor(Width-adjusted)



**MS-860-10**  
裤耳暗缝机  
Trousers Ears Blind Stitch Sewing Machine



**MS-101-QD3**  
工业用普及型电脑三自动暗缝机  
Computerized Blind Stitch Sewing Machine



**MS-1190BD**  
两面双撬暗缝机  
Industrial Double-faced Tacking Double Blind Stitch  
Sewing Machine



**MS-357BD**  
裤腰背置伺服驱动暗缝机  
Trousers Waist Blind Stitch Sewing  
Machine With Back-located Drive Motor



**MS-140-D**  
筒式暗缝机  
Direct Drive Tubular Type Blind Stitch  
Sewing Machine



**MS-1450BD**  
履带式双针暗缝机  
Crawler Type Double Needle Blind Stitch  
Sewing Machine

Model	Max speed	Stitch length	Skip device	Needle	G.W./N.W.	Volume
MS-361-BD	1800rpm/min	3.2-8.5mm	1:1,2:1	LWX6T 14#	24/35kg	620x490x360mm
MS-364QBD3	1800rpm/min	3.2-8.5mm	1:1,2:1	LWX6T 11#,14#	24/35kg	620x490x360mm
MS-370BD	1800rpm/min	3.2-8.5mm	无1:1	LWX6T 14#	24/35kg	620x490x360mm
MS-860-10	1800rpm/min	5-7mm	无1:1	L6T #14	24/35kg	620x490x360mm
MS-101-QD3	1800rpm/min	3.2-8.5mm	1:1,1:2	LWX6T 9#,11#,14#	24/35kg	620x490x360mm
MS-1190BD	1800rpm/min	3.2-8.5mm	1:1,2:1	LWX1669E LWX5T 16#	24/35kg	620x490x360mm
MS-357BD	1800rpm/min	3.2-8.5mm	无1:1	LW6T #14	24/35kg	620x490x360mm
MS-140-D	1800rpm/min			LWX6T 14#	24/35kg	620x490x360mm
MS-1450BD	1800rpm/min			LWX6T 14#	24/35kg	620x490x360mm



**MS-35800-DNU-DT**

差动麦夹机  
Direct-drive Crank Arm Type 4 Needles 6  
Threads Flat Seaming Machine Series

1. Suitable for thick fabric: Two or three needles can easily sewing 16 layers cloth;
2. Differential: Upper puller and differential feeding make sewing more smoothly.
3. Automation: Adopts a cylinder to control an presser foot lift, which makes sewing be easily;
4. Automatic fueling: Lower vibration and noise under high speed operation.
5. Application for jeans, casual pants, etc.

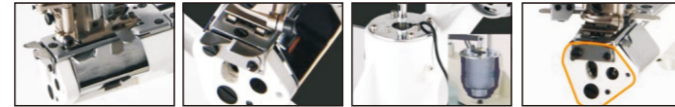

**MS-927-D**

直驱两针曲腕机  
Direct Drive 2 Needle Feed-off-the-arm  
Chainstitch Machine

**MS-927-PLB-D**

直驱两针曲腕机/直驱拖轮型  
Direct Drive 2 Needle Feed-off-the-arm  
Chainstitch Machine (Direct Drive Puller)

**MS-927-PSB-D**

直驱两针曲腕机/外置拖轮型  
Direct Drive 2 Needle Feed-off-the-arm  
Chainstitch Machine (External Puller)



**MS-928-D**

直驱三针曲腕机  
Direct Drive 3 Needle Feed-off-the-arm  
Chainstitch Machine

**MS-928-PL-D**

直驱三针曲腕机/直驱拖轮  
Direct Drive 3 Needle Feed-off-the-arm  
Chainstitch Machine (Direct Drive Puller)

**MS-928XH-2PL-D**

直驱三针厚料曲腕机 (直驱上下拖轮)  
Direct Drive 3 Needle Feed-off-the-arm Chainstitch  
Machine (Direct Drive Upper & Lower Puller)

MS-927-D	TVX64 14#	2	4	3/16, 1/4, 7/32, 1/8	1.2-5.2	10	3500	39/59	605X550X500
MS-927-PLB-D	TVX64 14#	2	4	3/16, 1/4, 7/32, 1/8	1.2-5.2	10	3500	39/59	605X550X500
MS-927-PSB-D	TVX64 14#	2	4	3/16, 1/4, 7/32, 1/8	1.2-5.2	10	3500	39/59	605X550X500
MS-928-D	TVX5 16#	3	6	1/4, 1/2, 3/8, 5/16, 9/32	2.6-4.8	10	3500	39/59	605X550X500
MS-928-PL-D	TVX5 16#	3	6	1/4, 1/2, 3/8, 5/16, 9/32	2.6-4.8	10	3500	39/59	605X550X500
MS-928XH-2PL-D	TVX5 16#	3	6	1/4, 1/2, 3/8, 5/16, 9/32	2.6-4.8	10	3500	39/59	605X550X500

Cutting  
Machine Series  
裁剪机系列





**MS-50A**  
圆刀裁剪机  
Round Knife Cutting Machine



**MS-110LA**  
圆刀裁剪机  
Round Knife Cutting Machine



**MS-RCS-100B/110B/125B**  
伺服圆刀裁剪机  
Small Round Knife With Servo Motor Cutting Machine



**MS-RCS-110/125**  
伺服圆刀裁剪机  
Small Round Knife With Servo Motor Cutting Machine



**MS-65A**  
圆刀裁剪机  
Round Knife Cutting Machine



**MS-70A**  
圆刀裁剪机  
Round Knife Cutting Machine



**MS-90A**  
圆刀裁剪机  
Round Knife Cutting Machine



**MS-CB125**  
圆刀裁剪机 (充电款)  
Cutting Machine With Battery



**MS-CB100**  
圆刀裁剪机 (充电款)  
Cutting Machine With Battery



**MS-100**  
圆刀裁剪机  
Round Knife Cutting Machine



**MS-110**  
圆刀裁剪机  
Round Knife Cutting Machine



**MS-125**  
圆刀裁剪机  
Round Knife Cutting Machine



**MS-CB70**  
圆刀裁剪机 (充电款)  
Cutting Machine With Battery



**MS-C50**  
圆刀裁剪机  
Cutting Machine With Battery



**MS-C1**  
圆刀裁剪机  
Cutting Machine With Battery

Model	Voltage	Power	Blade size	Blade speed	Crop height	Net weight
MS-50A	100v-240v	35w	50mm	600rpm	8mm	~1.4kg
MS-110LA	200v-240v	248w	110mm	2400rpm	32mm	~2.9kg
MS-65A	220v/110v	170w	65mm	2400rpm	22mm	~1.4kg
MS-70A	100v-120w 220v-240w	170w	70mm	2400rpm	25mm	~1.4kg
MS-90A	100v-120w 220v-240w	200w	90mm	2400rpm	23mm	~2.5kg
MS-100	220v/110v	100w	100mm	2400rpm	25mm	~2.9kg
MS-110	200v-240v	248w	110mm	2400rpm	32mm	~2.9kg
MS-125	220v	350w	125mm	750rpm	45mm	~4.3kg

Model	Power	Voltage	Blade Size	Cutting Height	Rotate Speed	Net Weight	Packing Size
MS-RCS-100B	200	110/220	100	27	600/800/1000/1200/1400rpm	1/1.5	350x260x130mm
MS-RCS-110B	200	110/220	110	32	600/800/1000/1200/1400rpm	1/1.5	350x260x130mm
MS-RCS-125B	200	110/220	125	40	600/800/1000/1200/1400rpm	1/1.5	350x260x130mm
MS-RCS-110	200	110/220	110	32	600/800/1000/1200/1400rpm	1/1.5	350x260x130mm
MS-RCS-125	200	110/220	125	40	600/800/1000/1200/1400rpm	1/1.5	350x260x130mm
MS-CB125	350	110/220	125	40	660	4/4.5	350x260x170mm
MS-CB100	250	110/220	110	32	660	4.25/4.5	350x260x170mm
MS-CB70	170	110/220	70	25	2400	1.4/1.5	350x260x130mm
MS-C50	35	110/220	50	5	2400	1/1.5	298x337x121mm
MS-C1	35	110/220	5	5		1/1.5	350x260x130mm



**MS-719**  
电脑伺服裁剪机  
Computer Servo Cutting Machine



**MS-709**  
电脑伺服裁剪机  
Computer Servo Cutting Machine



**MS-1603**  
电脑伺服裁剪机  
Computer Servo Cutting Machine



**MS-1500**  
电脑伺服裁剪机  
Computer Servo Cutting Machine



**MS-C3-550W/750W**  
裁剪机  
Stright Cutting Machine



**MS-C3-850W/1280W**  
裁剪机  
Stright Cutting Machine



**MS-K103**  
自动磨刀裁剪机  
Auto-Sharpener Cutting Machine



**MS-K108**  
自动磨刀裁剪机  
Auto-Sharpener Cutting Machine

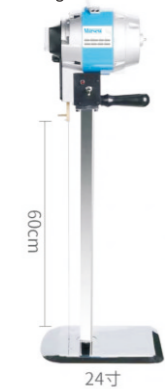

**MS-200A(24")**  
电热裁剪机  
Electric Heating Cutting Machine



**MS-03A**  
裁剪机  
Brushless Foam Rubber Cutter



**MS-F23**  
钻布机  
High Speed Cloth Drilling Machine



**MS-23H**  
钻布机 (加热)  
High Speed Cloth Drilling Machine  
(Electric Heating)

Model	Power W	Voltage V	Frequency Hz	Cutting height mm	Speed R.p.m	Net weight Kg	Packing size mm	Drilling Depth mm	Pin Specifications
MS-719	1000	110/220	50/60	110,160,210,260	1000-4000	15	760X405X320		
MS-709	1000	110/220	50/60	110,160,210,260	1000-4000	15	760X405X320		
MS-1603	550/750	110/220	50/60	110,160,210,260	1000-4000	15	760X405X320		
MS-1500	550/750	110/220	50/60	110,160,210,260	1000-4000	15	760X405X320		
MS-C3-550W/750W	550/750	110/220	50/60	110,160,210,260	1000-4000	15	760X405X320		
MS-C3-850W/1280W	550/750	110/220	50/60	110,160,210,260	1000-4000	15	760X405X320		
MS-K103	550/750	110/220	50/60	110,160,210,260	1000-4000	15	760X405X320		
MS-200A(24")	550/750	110/220	50/60	110,160,210,260,285	1000-4000	25	1060X405X320		
MS-F23	250				3000	6	575x295x255	≥100	1.2/1.6
MS-23H	250				3000	6	575x295x255	≥100	1.2/1.6

**MS-700BK/900BK**  
钢带机  
Band Knife Cutting Machine



1. According to different fabrics, the user can adjust various cutting speeds ;
2. It is attached with a special air-floated blowing device to reduce the excess resistance formed between the cutting sheet weight and cutting table. It makes easy move for cutting sheet and more precise cutting for small cutting shoots;
3. Extremely easy cutter removal;
4. It is attached with a grinding device to ensure constant sharp of the cutter;
5. Could be choose the belt safety protection device.

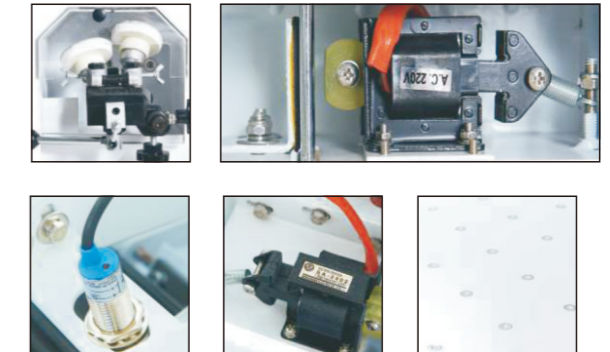

**MS-1200BK**  
钢带机  
Band Knife Cutting Machine



Band knife cutting series suitable for various fabric, woven / knitting / synthetic fiber( nylon, vinylon, acrylic ) / sponge / synthetic leather/ felt, etc

**Product Overview:**

- 1.Speed 3 level adjustable, for different material;
- 2.Easy to change the cutting knife;
- 3.With safety protection device;
- 4.Air-floated blowing table with small balls, easy to move;
- 5.With knife grinding device.

Model	MS-700BK	MS-900BK	MS-1200BK
Effective width right tool	700mm	900mm	1200mm
Cuting height	180mm	180mm	200mm
Bonding pressure	12Kpa	12Kpa	15Kpa
Cutting motor power	750W	750W	750W
Blower motor power	250W	250W	220V,250W/380V,400W
Linear velocity of tool	11.0; 12.2; 13.3m/rnin	11.0; 12.2; 13.3m/rnin	11.0;12.25; 13.35m/rnin
Tool specification	0.45x10x3500mm	0.45x10x3860mm	0.45x10x4560mm
V belt specification	A-1092mm	A-1346mm	A-1499mm
Worktable specification	1200x1400mm	1500x1800mm	1500x2400mm
Power supply	220V/1PH 380V13PH/50HZ	220V/1PH 380V13PH/50Hz	220V/1PH 380V/3PH/50Hz
G.W.	210kg	229kg	338kg
Out line dimension(LxWxH)	1920x1200x1614mm	2340x1500x1620mm	2862x1500x1570mm
Packing size	1530x745x1750mm	1870x745x1750mm	2500x745x1750mm

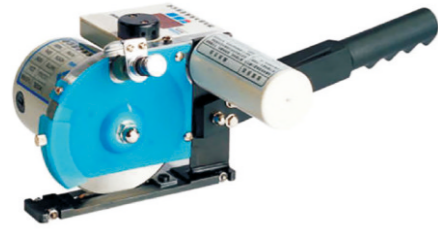

**MS-D108**  
断布机  
Cloth End Cutter



**MS-D108L**  
长柄断布机  
Long Arm Cloth End Cutter



**MS-D168**  
断布机  
Cloth End Cutter



**MS-C818**  
断布机  
Cloth End Cutter



**MS-DB2**  
半自动断布机  
Semi-Automatic Cloth End Cutter



**MS-DB3**  
全自动断布机  
Fully Automatic Cloth End Cutter

Model	Blade dimensions	Power	Voltage	Frequency	Gw/Nw	Packing size
MS-D108	φ108(4.25")	180w	110/220/240v	50hz	14.5/12kgs	960x380x195mm
MS-D108L	φ 108(4.3")	180w	110/220/240v	50/60hz	13/9kgs	755x415x245mm
MS-C818		180w	110/220/240v	50/60hz	13/9kgs	755x415x245mm
MS-D168	φ 108(4.3")	180w	110/220/240v	50/60hz	13/9kgs	755x415x245mm

Model	Power w	Voltage v	Frequency hz	Cutting width mm	Cutting height mm	Guide length mm	Speed rpm	Net weight kg	Packing size mm
MS-DB2	200	110/220	50/60	1.2-3.0	9	1.6-3.6	1200	23.8 24.6 22.2 23	855x490x325
MS-DB3	200	110/220	50/60	1.2-3.0	9	1.6-3.6	1200	23.8 24.6 22.2 23	855x490x325

**MS-A999**

裁床系列  
Cutting Bed Series

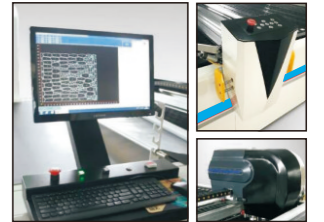

1. Through computer design, manual and automatic combination of computer can effectively improve the efficiency of nesting. As long as ordinary personnel are familiar with computer operation, they can also master nesting skills within a week;
2. The equipment can realize zero spacing cutting and effectively save raw materials;
3. Computer controlled automatic cutting can replace a large number of cutting workers and realize mass production;
4. Cutting bed control software supports multi-source data format, it can directly receive common clothing design and typesetting software;
5. The unique algorithm and motion control technology realize the seamless connection of straight line and arc line, and high cutting accuracy;
6. The equipment adopts automatic knife grinding technology, and the grinding time can be set according to the fabric characteristics effectively extending the service life of the cutter;
7. No need to print and keep the paper plate, which has high reuse rate and is convenient for plate making management;
8. The consumables are easy to be replaced and the replacement cost is low;
9. Variable frequency control: suction pressure can be set, effectively reducing the use cost of electric energy;
10. The conveyor belt in the picking area can be controlled independently or synchronously;
11. For special cutting window of rough brick, the blade can pierce into the surface at will without damage.

**MS-A888**

自动裁床系列  
Automatic Cutting Bed Series



1. **Cutter speed 6000r/min**  
High power motor combined with the new variable vibration box technology, the cutting power reaches the industry-leading level easily cutting all kinds of fabrics.
2. **Quick sharpening knife system**  
The sharpening mechanism of up to 15000r/min keeps the blade sharp at all times and improves cutting efficiency.
3. **Cutter cooling system**  
Specially designed double cold cutter, providing double cooling effect, combined with software algorithm, easy to deal with low melting point fabric, non-adhesion, cutting accuracy is higher.
4. **Play the linesman**  
The industry-leading global algorithm, combined with the top hardware, together constitute a full-time dynamic cutting technology to achieve real time cutting of fabrics through the window to greatly improve production efficiency, while reducing the fabric repeated adsorption bias and connection waste.
5. **Zero gap cutting**  
Different from software typesetting, excellent algorithms and high-precision cutting system can achieve zero gap cutting, saving more fabrics for users.
6. **Dynamic cutting speed**  
For adjacent cutting pieces and edge cutting pieces, the cutting head can dynamically adjust the cutting speed according to the actual cutting area to achieve the balance between cutting accuracy and efficiency.
7. **Tailoring job support system**  
The clipping path can be memorized in real time during clipping and can be clipped quickly after power recovery to improve efficiency.

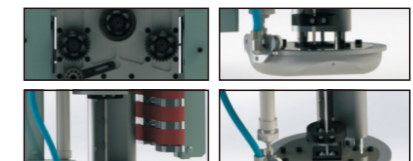

Model	Voltage	Pressure	Power	Cutting area	Cutting thickness	Weight	Dimension
MS-A999	380V	0.5Mpa	25kw	3000LX1560W	70mm	2500kg	7000Lx2800Wx1900H
MS-A888	380V	0.5Mpa	25kw	3000LX1560W	70mm	2500kg	7000Lx2800Wx1900H

**MS-1900**

智能铺布机  
Auri-tech Automatic Spreading Machine

Automatic spreading machine, suitable for woven, knitted fabric. It suitable for woven and scaling properties of fabrics, it is equipped with PLC programmable computer control, adoption of the advanced touch screen operation, convenient to set the length, layer number of LABS, speed, and etc. Adopt the bucket cloth basket design, to facilitate loading large rolls of cloth. At the same time can also be in the process of lab for any response operation condition. Automatic deceleration function, can reduce the length of the settings, to prevent the accident.

1. Touch screen operation interface, real-time visualization, set up simple, operation easy;
2. Automatic edge functions in real time during the filibuster on the side, saving fabric;
3. No cloth shutdown, automatic drove back the origin, no tension raab, stream line operations, improve production efficiency;
4. Remote control emergency stop mode, real-time control, fast and safe;
5. Spreading machine speed variation by computer PLC control, stable and safe.

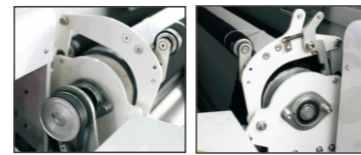
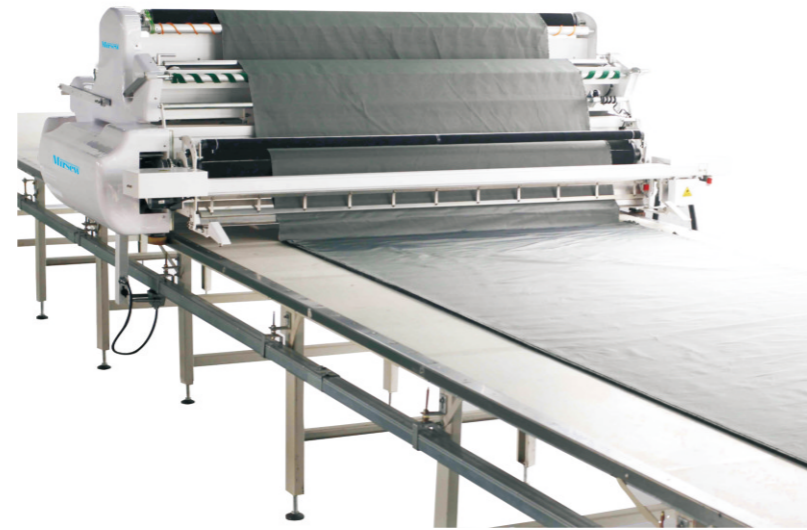

**MS-MC02**

服装模板切割机  
Garment Template Cutting Machine

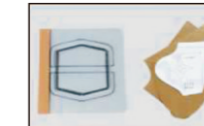

1. Multi-tools for cutting both PVC board and cardboard;



2. Leading auto knife-depth adjustment function, easy to set the cutting depth;



3. Imported straight rail, with high cutting speed and high precision;



4. Free template design software, easy to design and work with machine

5. Divisional vacuum absorption;
6. Work with any CAD software in Garment industry, Shoes industry, Bag industry etc

Model	MS-MC02
Air pump specifications	1.5kwX2
Power	5kw
Effective cutting area(mm)	1500mmX900mm
Overall dimension	2100mm*1536mm*920mm
Cutting thickness	≤8mm
Max.spindle speed	60000r/min
Cutting speed	100-1200mm/s
Repeat precision	≤0.01mm
Software resolution	0.025mm
Voltage/power	Ac220v+10%,50hz
Fuse	6a/30a

**MS-MC03**

模板切割机  
Template Cutting Machine



Multi functional, quick switching of cardboard and PVC boards



Quickly adjust cutting thickness



LCD display, Chinese/English operation panel



Pneumatic fixtures for more secure fixation

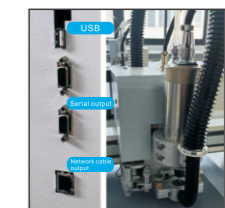

1. Multiple output methods
2. High speed / ultra high speed water-cooled machine head

Model	MS-MC03
Max area(LxW)	1500X900MM
Voltage/power	AC220v 50/60Hz/4.5kw
Working speed	0-100mm/s
Knife handle diameter	3.175mm 4mm
Machine size(LxWxH)	1980x1420x1080mm
Packing size(LxWxH)	2200x1520x1150mm
Machine weight	300kg

Model	Spreading width	Raab height	Max.speed	Weight of cloth roll	Cutting table width	Cutting height	Voltage	Power	Cimension
MS-1900	1600mm	190mm	80m/min	50kg	1830mm	700mm±30	220v/50-60hz	2.3kw	1500x2170x900mm

**MS-SC1209**

裁床之单片裁剪系列  
Cutting Bed Single Piece Cutting Series

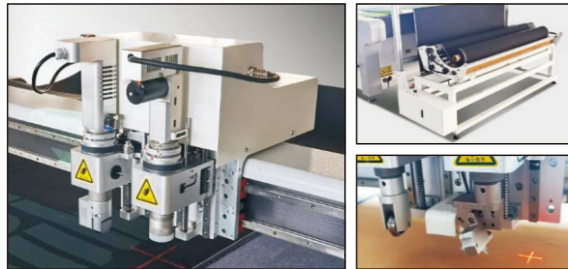

**Control system:**

Equipped with an advanced multi axis high-speed motion control system, the system is easy to upgrade and maintain, with high reliability and low cost. It can easily customize special programs for personalized user needs and perform remote upgrades;

**Integrated control:**

The control card is integrated into the device, eliminating the need for a computer chassis to control the device, making maintenance more convenient;

**Head design:**

Adopting a replaceable tool head mode, the tool head is non fixed welded and integrated, allowing for convenient replacement and addition of different functional tool heads according to actual work needs and business scope expansion;

**Working mode:**

Using the He Fu motor to drive the screw control mode, it can be linked with the computer to preset the depth of the right storage knife according to different needs, making it convenient for digital fine-tuning;

**Body countertop:**

A high-strength body designed for mass production, with high-speed cutting and no shaking, the equipment operates more stably for a long time. It has a continuous rolling platform and is equipped with a multi-point adjustable keel style honeycomb aluminum plate tabletop, which is durable, not deformed, and even;

**Security protection:**

Install safety anti-collision and infrared blocking devices in the crossbeam work area to ensure personnel safety;

**Automatic edge finding:**

Can be configured with a top camera positioning system to automatically search for edges, cut or set the printing material;

**Software features:**

Compatible with mainstream CAD design software on the market, the control center software can set any cutting path energy: The diameter, starting and falling points of the cutting tool can be effectively improved and materials can be saved through the layout function;

**Reduction device:**

Adopting a high-end servo system with fast speed and high-performance deceleration device, high long-term accuracy;

**Other advantages:**

The rolling platform can achieve continuous cutting, with good splicing effect and time-saving and material saving: it adopts an overall air suction method (intelligent partitioning can be selected), which has stronger adsorption force.

Model	Cutting speed	Cutting thickness	Cutting accuracy	Power	Voltage	Scope of work	Size
MS-SC1209	≤2000mm/s	≤50mm	±0.1mm	6.5kw	220v±10%, 50Hz	1200x900mm	1960x1550x1380mm

Belt Cutting  
Machine Series  
切带机系列



## Model Differentiation

# MS-120HLR

Brand

### Products series

- 2200: Ultrasonic Cutting Machine
- 150: Automatic Multi-function Cutting Machine
- 130: Heavy-duty Auto-cutting Machine
- 120: Automatic Cutting Machine
- 110: Economical Auto-cutting Machine
- 817: Mechanical Cutting Machine

#### L: Cold Knife Cutter

It can cut a variety of different materials such as: nylon tape, cotton tape, soft plastic tube, computer cables etc, but only cold cutting without heat-sealing function.

#### LR: Cold & Hot Knife Cutter

If closing the heating switch, the machine will become a cold cutter and it can cut a variety materials same as "L". It can cut nylon materials with sealing the edge once open the heat switch except the thick and cotton materials.

#### H: Hot Knife Cutter

It can cutting variety of different materials same as "L". In addition to these, especially to sealing function is good at melting normally thick materials except cotton materials.

#### SH: Auto-label Hot Knife Cutter

This same as "H" function, it has color sensor device so it also can cutting variety of different lable materials.

#### HLR: Auto-label Cold & Hot Knife Cutter

This same as "LR" function, it has color sensor device so it also can cutting variety of different lable materials.

#### HL: Auto-label Cold Knife Cutter

This same as "L" function, it has color sensor device so it also can cutting variety of different lable materials.

#### HX: Bevel & Straight Cutter

It is a bevel & straight cutting machine with hot knife to sealing the edge, do not change the knife and direct loosen the screw to change the knife angle to reached customers request.

#### R: Velcro Tape Round Shape Cutter

It is a velcro cutting machine, it can cutting many different shapes to reached customers request!

## 110 And 120 Series (Motor And Cylinder Models Are Optional)

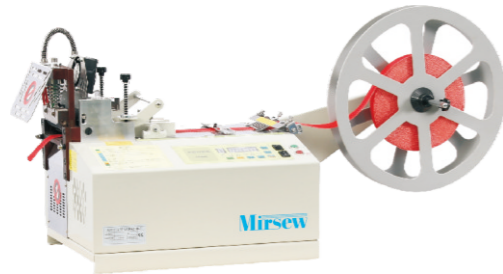

**MS-110LR**  
电脑切带机 (冷、热)  
Economic Belt Loop Cutter(Cold & Hot)



**MS-110H**  
电脑切带机 (热刀)  
Economic Hot Knife Cutter



**MS-110L**  
电脑切带机 (冷刀)  
Economic Cold Knife Cutter



**MS-110HLR**  
电脑切带机 (冷、热红外)  
Economic Label Cutter(Cold & Hot)



**MS-110R**  
电脑切带机 (圆角)  
Economic Velcro Tape Round Cutter

Model	Cutting length mm	Max.cutting width mm	Cutting Speed p/min	Max.Blade Temp °C	Voltage v	Frequency Hz	Power kw	Packing Size mm	Weight kg
MS-110LR	20-9999	95	95	350	110/220	50/60	0.64	560x420x405	17/22
MS-110H	20-9999	100	95	420	110/220	50/60	0.64	560x420x405	17/22
MS-110L	20-9999	104	95	—	110/220	50/60	0.26	560x420x405	17/22
MS-110HLR	20-9999	95	95	350	110/220	50/60	0.64	560x420x405	17/22
MS-110R	20-9999	10-50	95	—	110/220	50/60	0.26	560x420x405	17/22



**MS-120LR**  
电脑切带机 (冷、热)  
Auto-Belt Loop Cutter(Cold & Hot)

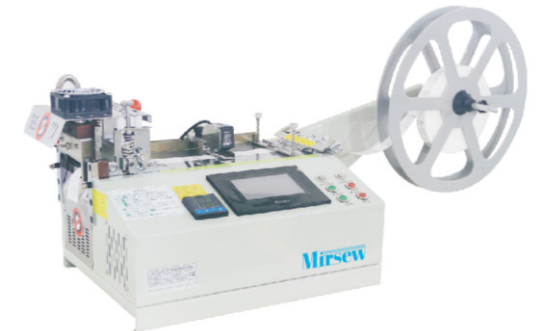

**MS-120HLR**  
电脑切带机 (冷、热红外)  
Label Cutter(Cold & Hot)



**MS-120R**  
电脑切带机 (圆角)  
Velcro Tape Round Shape Cutter



**MS-120HL**  
电脑切带机 (冷刀红外)  
Label Cold Knife Cutter



**MS-120HX**  
电脑切带机 (斜角/直角)  
Hot Knife Cutter ( Bevel / Straight )



**MS-120SH**  
电脑切带机 (热刀红外)  
Auto-Label Hot Knife Cutter

Model	Cutting length mm	Max.cutting width mm	Cutting Speed p/min	Max.Blade Temp °C	Voltage v	Frequency Hz	Power kw	Packing Size mm	Weight kg
MS-120LR	20-9999	95	90	350	110/220	50/60	0.66	560x420x405	24/29
MS-120HLR	20-9999	95	120	350	110/220	50/60	0.75	560x420x405	24/29
MS-120R	20-9999	10-50	80	—	110/220	50/60	0.35	560x420x405	24/29
MS-120HL	20-9999	105	120	—	110/220	50/60	0.35	560x420x405	24/27
MS-120HX	20-9999	35/55	120	420	110/220	50/60	1.15	560x420x405	24/29
MS-120SH	20-9999	100	120	420	110/220	50/60	0.75	560x420x405	24/29



**MS-300M**  
电脑送带机  
Tape Feeder

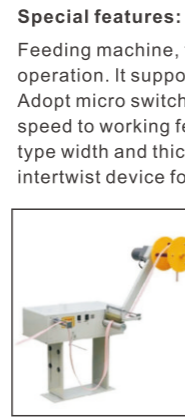

**MS-300S**  
电脑送带机  
Tape Feeder



**MS-815/817**  
切带机 (冷、热刀)  
Belt Cutter (Cold & Hot)

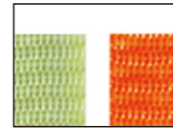

**Application:**  
Velcro tapes

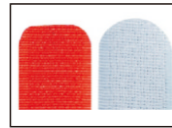

**MS-818**  
切带机 (圆角)  
Velcro Tape Cutter(Round)



**MS-2100**  
超声波电脑切带机 (直角)  
Ultrasonic Cutting Machine(Right Angle)



**MS-2200**  
超声波电脑切带机 (直角/转角)  
Ultrasonic Cutting Machine(Right Angle/Bevel)

**Special features:**  
Feeding machine, this device is for multi-purpose pre-feeding, easy operation. It support the use for cutting machine, sewing machine etc. Adopt micro switch device, could according to the main machine working speed to working feeding function automatically. It suitable for different type width and thickness woven belt, elastic belts, labels etc. The anti intertwist device for make the belt untie and twisting.

**MS-150LR**  
多功能电脑切带机 (冷、热刀)  
Auto-cutting Machine  
(Multi-function Cold & Hot Cutter)



- 1.High speed: It can cut 150 pcs per minute. (e.p. 50 mm long, it include collecting device);
  - 2.Accuracy: Cut-length is accurate owing to a stepping motor;
  - 3.Collecting Function: Setting the quantity, it will be collecting automatically, so that clients can be easily packed;
  - 4.Punching Device: According to the needs of user, it can punch different size of the diameter of the holes;
  - 5.Cutting Type: The blade is made of high quality steel. Hot cutter can cut ribbon, thin woven belt and the hot knife melts the end of the tape, cutting is sealed neatly, smoothly without fraying;
  - 6Automatic operation: It works automatically only by setting length and quantity. it stops automatically if materials runout dunnig operation;
  - 7.Computerised: Automatic work, stop. The special fault by self-diagnosis, direct show the fault problem on the screen, it will easy for you to find clear way to repair;
  - 8Automatic stopper: It stops automatically if materials run out during operation;
  - 9.Memory: Set-length, set quantity & set speed are not erased even if power off & on;
- Applications: All kinds of woven belt, velcro, shoelace, plastic soft tube, computer cable, label etc.



**MS-150L** (Cold Cutter)



**MS-150HX** (Bevel Cutter)

**MS-130LR**  
电脑切带机 (冷、热刀)  
Heavy-Duty(Cold & Hot) Knife Cutter



- Special features:**  
**High speed:** It can cut 150 pcs per minute. (e.p. 50 mm long)  
**Accuracy:** Cut-length is accurate owing to a stepping motor.  
**Cutting Type:** Melting & cutting by hot knife, woven label is cut neatly without fraying but not for heavy materials and installed with anti-static electricity device.  
**Automatic operation:** It works automatically only by setting length and quantity.  
**Automatic stopper:** It stops automatically if materials run out during operation.  
**Memory:** Set-length, set quantity & set speed are not erased even if power off&on.  
**Applications:**Woven tapes, strip tapes, bag band etc.



**MS-130H** (Hot Cutter)



**MS-130L** (Cold Cutter)



**MS-130R** (Round Shape Cutter)

Model	Feeding Speed mm	Max. Feeding Width mm	Motor Speed r/min	Voltage v	Frequency Hz	Packing Size mm	Weight kg
MS-300M	AUTO	140	1500	110/220	50/60	560x415x400	14
MS-300S	AUTO	100	1300	110/220	50/60	450x445x405	22

Model	Cutting Length mm	Max. Cutting Width mm	Cutting Speed p/min	Package Size mm	Weight kg	Loading Rate Pic
MS-815	15-1500	50	23-35	500x340x455	23	1
MS-817	15-1500	50	23-35	500x340x455	23	1
MS-818	15-1500	25	23-35	500x340x455	23	1

Model	Cutting length mm	Max.cutting width mm	Cutting Speed p/min	Voltage v	Frequency Hz	Power kw	Packing Size mm	Weight kg
MS-2100	50-9999	150	150	110/220	50/60	3	860x500x1530	178
MS-2200	50-9999	150	100/35	110/220	50/60	3	860x500x1530	152

Model	Cutting length mm	Max.cutting width mm	Cutting Speed p/min	Max.Blade Temp °C	Voltage v	Frequency Hz	Power kw	Packing Size mm	Weight kg
MS-130R	20-9999	20-100	120	—	110/220	50/60	0.3	550x445x465	107
MS-150HX	30-9999	65/40	150	420	110/220	50/60	1.05	820x570x780	77.5
MS-150LR	30-9999	95	150	350	110/220	50/60	1.2	820x570x780	77.5
MS-150L	30-9999	95	150	—	110/220	50/60	0.3	820x570x780	77.5
MS-130LR	20-9999	200	150	350	110/220	50/60	0.9	550x445x465	105
MS-130H	20-9999	200	150	400	110/220	50/60	0.9	550x445x465	112
MS-130L	20-9999	200	150	—	110/220	50/60	0.3	550x445x465	107

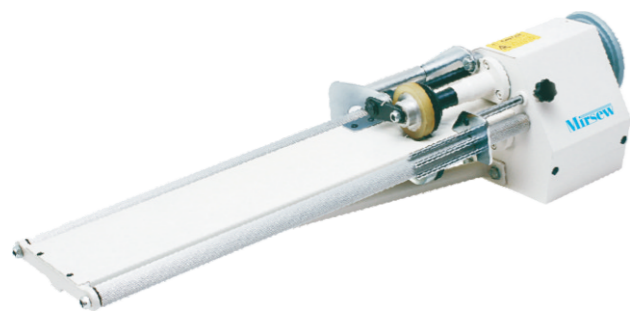

**MS-801A**  
单刀切布条机  
Cloth Tape Cutting Machine  
(Single Knife)

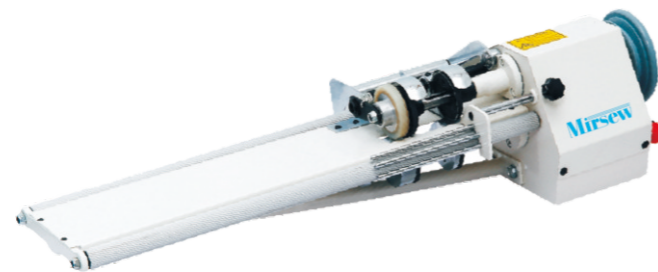

**MS-802A**  
双刀切布条机  
Cloth Tape Cutting Machine (Double Knife)

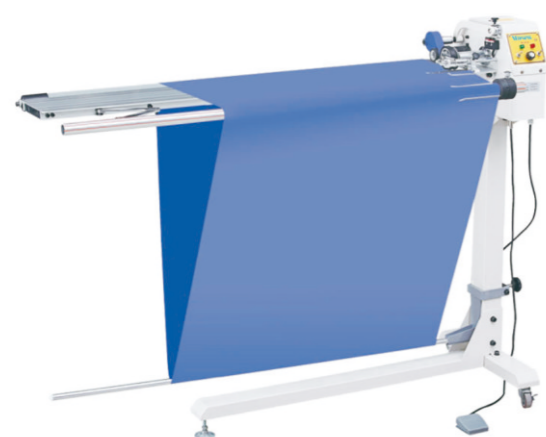

**MS-911A**  
切布条机  
Cloth Tape Cutting Machine



**MS-933A**  
切布条机  
Cloth Tape Cutting Machine

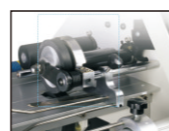

Model	Motor Pulley	Speed r/min	Voltage v	Frequency hz	Power kw	Package Size mm	Weight kg	Loading Rate Pic
MS-801A	4" ~5.5 "	1400	220	50/60	1/4	820x350x240	25	1
MS-802A	4" ~5.5 "	1400	220	50/60	1/4	820x350x240	25	1

Model	Power	Cutting Speed	Cutting Width	Packaging Size	Table Length	Machine Weight
MS-911A	60w	0-50m/min	0-10cm	1640x470x380mm	145cm	53kg
MS-933A	60w	0-50m/min	0-10cm	1640x470x380mm	145cm	53kg

# Household Sewing Machine Series

## 家用缝纫机系列



**MS-ES6**  
家用电脑绣花机  
Household Computer Embroidery Machine

- 1.7 inch color touch screen;
- Patterns, colors, sizes, directions can be edited freely;
- Embroidery status can be monitored in real time;
- Easy to use, one will learn;
- Sewing stitches can be edited in combination;
- Multiple buttonhole.

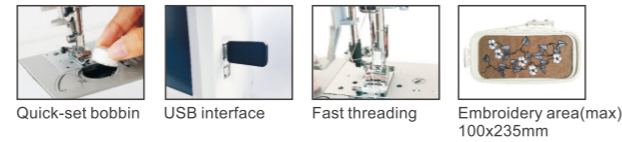

- Max Embroidery area:235\*100mm
- With LED display screen
- With auto thread cutter
- With auto bobbin winding
- With thread break alarm
- Embroidery file format: DST
- Operation software support: XP/Win7/Win8/Win10



**MS-890**  
家用电脑绣花缝纫一体机  
Household Computer Embroidery Sewing Integrated Machine



**MS-ES5**  
家用电脑缝绣一体绣花机  
Household Computer Embroidery Machine  
Sewing Integrated Machine



**INNOVATION**

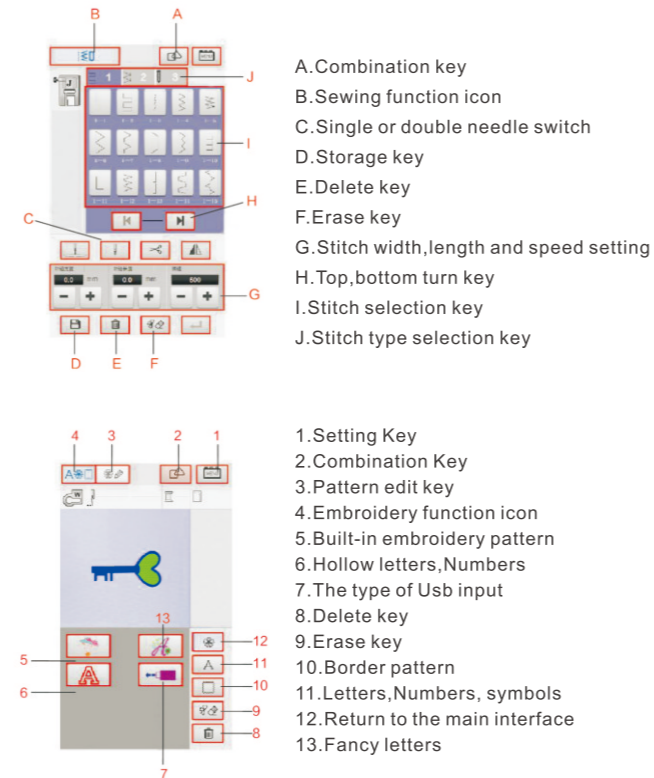

- A. Combination key
  - B. Sewing function icon
  - C. Single or double needle switch
  - D. Storage key
  - E. Delete key
  - F. Erase key
  - G. Stitch width, length and speed setting
  - H. Top, bottom turn key
  - I. Stitch selection key
  - J. Stitch type selection key
- 
- 1. Setting Key
  - 2. Combination Key
  - 3. Pattern edit key
  - 4. Embroidery function icon
  - 5. Built-in embroidery pattern
  - 6. Hollow letters, Numbers
  - 7. The type of Usb input
  - 8. Delete key
  - 9. Erase key
  - 10. Border pattern
  - 11. Letters, Numbers, symbols
  - 12. Return to the main interface
  - 13. Fancy letters

**MS-1500B**  
家用电脑绣花机  
Household Computer Embroidery Machine



**MS-890B**  
家用电脑绣花缝纫一体机  
Household Computer Embroidery  
Sewing Integrated Machine



**MS-1212**  
多功能家用机  
Multi-Function Household Sewing Machine



**MS-703**  
家用包缝机  
Household Overlock Sewing Machine



**MS-434D**  
家用包缝机  
Household Overlock Sewing Machine



**MS-J1-1**  
家用平缝机  
Household Lockstitch Sewing Machine



Model	Power	Net weight	Gross weight	Packing size	Sewing speed	Scope of stitch	The needle of range	Embroidery area
MS-ES6	45w	8.9kg	12kg	445x365x385mm	0-650rpm	0-4mm	0-7mm	100x235mm
MS-ES5	45w	8.9kg	12kg	445x365x385mm	0-650rpm	0-4mm	0-7mm	100x235mm

Model	Power	Net weight	Gross weight	Packing size	Sewing speed	Scope of stitch	The needle of range	Embroidery area
MS-890	45w	8.9kg	12kg	445x365x385mm	0-850rpm	0-4mm	0-7mm	100x235mm
MS-1500B	45w	8.9kg	10.5kg	445x365x385mm	650rpm			100x235mm
MS-890B	45w	8.9kg	10.5kg	445x365x385mm	0-650rpm			100x235mm
MS-1212	70w	5.5kg	8.5kg	445x365x385mm	0-750rpm	0-4mm		
MS-703	90w	6.2kg	8.5kg	448x363x319mm	0-750rpm	1-4mm		
MS-434D	90w	8.5kg	10kg	448x363x319mm	1300rpm	1-4mm		
MS-J1-1	90w	10kg	10.1kg	420x200x290mm	1000rpm	6.5mm		

**TAIL PLUG**



W36 W35 W29 W17 W16



W13 W11-A W11 W3SKD-A 3SKD

**PLUG**



T14 T13 T10 T11



MS-3903(Grey) MS-3902(Black) MS-2902



MS-M2001 TS-03(Carbon brush) MS-M3001 FC-01



MS-P01 PFAFF  
1/4 Ince Edge Joining Foot



MS-P02 PFAFF  
Zipper/cording Foot

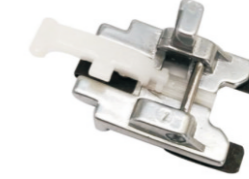

MS-P03 PFAFF  
Sew-on Button Foot



MS-P04  
Foot Snap-on



MS-P05 PFAFF  
Multi-cord Foot



MS-P06 PFAFF  
Beading Foot For 6mm Beads



MS-P07 PFAFF  
Decorative Foot



MS-P08 PFAFF  
Zipper Foot



MS-P09 PFAFF  
Applique Foot



MS-P10 PFAFF



MS-P11 PFAFF  
Non-stick Foot



MS-P12 PFAFF  
Invisible Zipper Foot



MS-P13 PFAFF  
Fancy Stitch Foot



MS-P14 PFAFF  
3mm Rolled Hem Foot



MS-P15 PFAFF  
Pintuck Foot With  
Decorative Stitch Guide



MS-P16 PFAFF  
Roller Foot



MS-P17 Viking  
Braiding Foot

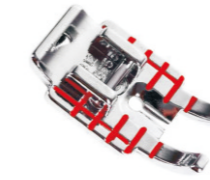

MS-P18 Viking  
1/4 Piecing Foot



MS-P19 Viking  
1/4 Piecing Foot With Guide



MS-P20 Viking  
Adjustable Blind Hem Foot



MS-P21 Viking  
Clear B Edge Joining Foot



MS-P22 Viking  
Chenille Foot



MS-P23 Viking  
Clear Seam Guide Foot



MS-P24 Viking  
14 Piecing Foot

			
MS-121201 Gear	MS-121202 Gear	MS-121203 Gear	MS-121204 Gear
			
MS-121211 Bobbin Case	MS-121212 Bobbin Case	MS-121221 Knife	MS-121222 Knife
			
MS-121223 Knife	MS-121231 (8mm) Pulley	MS-121232(7mm) Pulley	MS-121241 Needle Threader
			
MS-121251 Bobbins	MS-121252 Bobbins	MS-121253 Bobbins	MS-121261 Feed Dog
			
MS-121262 Feed Dog	MS-121271 Gear Rack	MS-121281 Needle Plate	MS-121282 Needle Plate
			
MS-121283 Needle Plate	MS-121291 Spool Pin	MS-121292 Spool Pin	MS-121293 Spool Pin

# Ironing Machine Series

整烫系列



**MS-G4040Q/5040Q/6040Q**

单工位旋转式气动烫画机(特氟龙发热板)  
Swing-away Pneumatic Heat Press Machine  
With Slide-out Base (Teflon Heating Plate)



1. Slide-out base;
2. 12 heating coils in 2.5cm thick aluminum plate;
3. Head rotation 90/145/180 degrees;
4. Heating plate triple thermal protection;
5. Insert T-shirt(ready-to-wear clothing);
6. Heating plate and nuts are two layers protection against high temperature;
7. Heating plate falls automatically when the heating plate overlaps with the lower plate, higher efficient.

Heating plate size	Voltage	Power	Temperature range	Time range	Weight	Packing size
30x20/12x8	220/110v	1/0.8kw	0-299°C	0-999s	45kg	80x53x60cm
40x30/16x12	220/110v	1.3/1kw	0-299°C	0-999s	50kg	80x53x60cm
40x40/16x16	220/110v	2/1.5kw	0-299°C	0-999s	58kg	80x53x60cm
50x40/20x16	220/110v	2.5/1.8kw	0-299°C	0-999s	68kg	80x53x60cm
60x40/24x16	220/110v	3/2kw	0-299°C	0-999s	75kg	80x53x60cm

**MS-2020/2525/2030/1535/4040-YD2 4050/4060-QD2**

双工位旋转式气动烫画机(特氟龙发热板)  
Swing-away Pneumatic Double-station Heat Press Machine(Teflo Heating Plate)

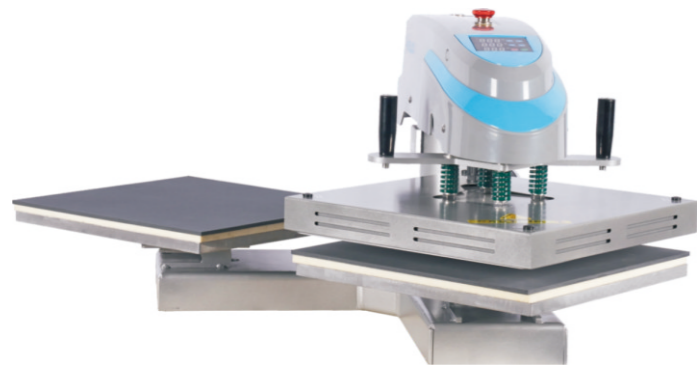

1. Twin station for higher efficiency;
2. 12 heating coils in 2.5cm thick aluminum plate;
3. Head rotation 180 degrees;
4. Heating plate triple thermal protection;
5. Insert T-shirt(ready-to-wear clothing);
6. Heating plate and nuts are two layers protection against high temperature;
7. Gas cylinder can adjust the pressure, pressure is more stable;
8. Emergency stop button can rise heating plate and stop to work in case of emergency;
9. Heating plate falls automatically when the heating plate overlaps with the lower plate, higher efficient;
10. Lower plate protector cover (high temperature cover).

Heating plate size	Voltage	Power	Temperature range	Time range	Weight	Packing size
20x20/8x8	220/110v	0.8/0.6kw	0-299°C	0-999s	45kg	97x62x50cm
20x30/8x12	220/110v	1/0.8kw	0-299°C	0-999s	50kg	97x62x50cm
25x25/10x10	220/110v	1/0.8kw	0-299°C	0-999s	50kg	97x62x50cm
30x40/12x16	220/110v	1.3/1kw	0-299°C	0-999s	57kg	97x62x50cm
40x40/16x16	220/110v	2/1.5kw	0-299°C	0-999s	60kg	97x62x50cm



**MS-4040/6040/7050-TD2**

双工位上滑式气动烫画机(特氟龙发热板)  
Up-sliding Pneumatic Double-station Heat Press Machine For T-shirt(Teflon Heating Plate)



**MS-4040/6040/7050-TD2L**

双工位上滑式红外线定位气动烫画机(特氟龙发热板)  
Up-sliding Pneumatic Double-station Heat Press Machine With Infrared Positioning For T-shirt (Teflon Heating Plate)



**MS-4040/4060/5070-XTD2-P**

双工位下滑式气动烫画机  
Down-sliding Pneumatic Double-station Heat Press Machine(Two Person Opposite Working)



**MS-4080/6080/7090-TD2**

双工位上滑式气动烫画机  
Up-sliding Pneumatic Large Format Double-station Heat Press Machine



**MS-25100/40100-BF-TD2-N**

多工位上滑式下吸风气动烫标机  
Up-sliding Multiple-station Bottom  
Suction Labeling Machine

**MS-4060/4080-BF-XTD2-N**

双工位下滑式吸风气动烫画机  
Double-station Down-sliding Heat  
Press Machine With Bottom  
Suction Device

**MS-4040/4050/4060-04-Y**

四工位全自动液压旋转式烫画机(特氟龙发热板)  
Full Automatic Hydraulic Four-station  
Heat Press Machine(Teflon Heating Plate)

**MS-2020A/2525A/4040A/  
4060A/6080A-TD2**

双工位上滑式上下发热气动烫画机(特氟龙发热板)  
Up-sliding Pneumatic Double-station Heat Press  
Machine With Up And Down Heating (Teflon  
Heating Plate)

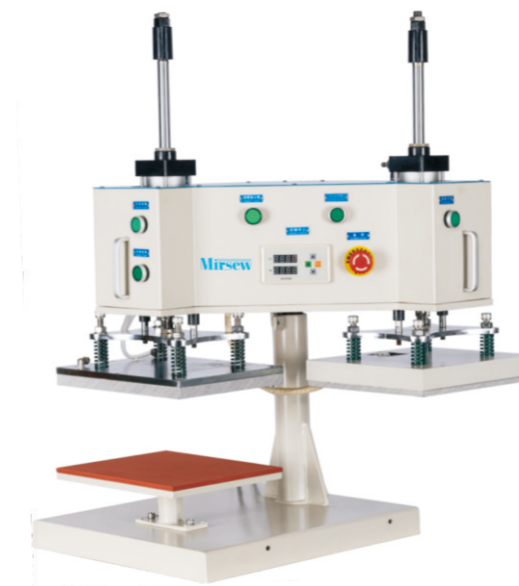

**MS-4080/6080/7090/25100/  
60100/80100/100120-DZ-P**

单工位下抽拉气动烫画机  
Pneumatic Large Format Heat Press  
Machine With Slide-out Base

**MS-8060/4060-YTD2**

双工位上滑式八臂无缝侧骨压烫机  
Up-sliding Pneumatic Eight-bar  
Seamless Side Bone Ironing Machine

**MS-230-C-H**

双工位旋转式冷热压烫机(特氟龙发热板)  
Pneumatic Heat Press Machine With  
Cool Plate (Teflon Heating Plate)

**MS-1515/2020/1030/2030/  
2525/1535-TD2**

双工位上滑式气动烫标机(特氟龙发热板)  
Up-sliding Pneumatic Double-station Heat  
Press Machine Teflon Heating Plate



**MS-470-UK**  
单工位弧形袖口压烫机  
Pneumatic Curve Cuff Heat Press Machine



**MS-1515D/2020D/2030D/  
2525D/1535D/4040D/4060D**  
单工位气动烫画机(特氟龙发热板)  
Pneumatic Heat Press Machine For  
Labels(Teflon Heating Plate)



**MS-38/64**  
手动烫画机(特氟龙发热板)  
Manual Heat Press Machine  
(Teflon Heating Plate)



**MS-84**  
高压手动烫画机  
Manual Heat Press Machine



**MS-25100-WD**  
单工位织带手动热转印机  
Webbing Manual Heat Transfer  
Printing Machine



**MS-B3/B2/B1**  
家用智能热转印机  
Domestic Smart Heat Press Machine



**MS-380H/540H/640H-P**  
单工位底板抽拉磁性半自动成衣烫画机(特氟龙发热板)  
Semi-auto Heat Press Machine With Slide-out  
Base And Auto Open (teflon Heating Plate)



**MS-380H/540H/640H-D2**  
双工位下滑式磁性半自动成衣烫画机(特氟龙发热板)  
Dual-station Slide-down Magnetic Semi-automatic  
Garment Heat Press Machine (Teflon Heating Plate)



**MS-38B-P**  
底板抽拉手动烫画机  
Manual Heat Press Machine  
With Slide-out Base



**MS-38A**  
手动烫画机  
Manual Heat Press Machine



**MS-158A**  
手动烤帽烫画机  
Manual Roasting Cap Machine



**MS-1508**  
磁性半自动烤帽烫画机  
Magnetic Semi-automatic Cap Heat Press Machine



**MS-HY-BA**  
电脑衬衫领袖整烫机  
Computerized Sleeve & Collar Ironing Machine



**MS-HY-BB**  
电脑烫边机  
Computerized Side Edge Ironing Machine



**MS-HY-AA**  
电脑双袖外弯整烫机  
Computerized Double Sleeve External Curvature Ironing Machine



**MS-HY-AB**  
电脑左右肩整烫机  
Computerized Left & Right Side Shoulder Ironing Machine



**MS-HY-BC**  
电脑门襟整烫机  
Computerized Placket Ironing Machine



**MS-HY-BD**  
电脑衬衫后背整烫机  
Computerized Back Shoulder Ironing Machine



**MS-HY-BE**  
电脑手臂套烫机  
Computerized Arm Sleeve Ironing Machine



**MS-HY-AC**  
电脑左大身整烫机  
Computerized Left Side Body Edge Ironing Machine



**MS-HY-AD**  
电脑右大身整烫机  
Computerized Right Side Body Edge Ironing Machine

- 1.It is mainly used for formal clothes such as suits and shirts, etc., clothing is flat knit after ironing;
- 2.Mainly divided into steam ironing and electric ironino. accordina to the material and thickness of diferent tyes of machines can be selected;
- 3.According to the different parts of the clothing to make a different mold, each part of the special stereotypes;
- 4.Steam ironing: only by steam spraying and pressure on the upper and lower mold to set;
- 5.Electric heating iron: only on electric heating and upper and lower mould pressure to finalize the design;
- 6.Permanent ironing: both gush steam and electricity heating and upper and lower mould pressure to finalize the design.

Model	Power(KW/V)	Compressed air pressure(MPA)	Packing Size(cm)	Weight (kg)
MS-HY-BA	4.2/220	0.3-0.5	120x104x125	340
MS-HY-BB	4.8/380	0.3-0.5	120x104x135	340
MS-HY-BC	2.5/220	0.3-0.5	120x105x135	340
MS-HY-BD	2.5/220	0.3-0.5	110x105x222	410
MS-HY-BE	2.5/220	0.3-0.5	100x105x135	290

Model	Steam wastage(kg/h)	Power(KW/V)	Compressed air pressure(MPA)	Packing Size(cm)	Weight (kg)
MS-HY-AA	10	3.2/380	0.3-0.5	135x123x142	410
MS-HY-AB	10	1.6/220	0.3-0.5	105x115x240	410
MS-HY-AC	10	4.8/220	0.3-0.5	120x122x142	400
MS-HY-AD	10	4.8/220	0.3-0.5	120x122x142	400



**MS-YY801**  
整烫一体机  
Vacuum Ironing Table with Build-in Steam Generator(82\*122/82\*152)



**MS-TDZG-Q3**  
琴式吸风一体烫台  
U Shape Vacuum Ironing Table(39\*120)



**MS-TDG-B6**  
整烫一体机  
Vacuum Ironing Table with Build-in Steam Generator(65\*120)



**MS-TD-B1(750W)**  
吸风烫台  
Vacuum Ironing Table(65\*120/80\*120/80\*150)



**MS-TDZC-Q6**  
琴式吹吸风烫台升降款  
U Shape Vacuum & Blow Ironing Table  
Conversion Ironing Table With Raising And Falling



**MS-TDG-B1**  
整烫一体机  
Vacuum Ironing Table with Build-in Steam Generator(82\*122/82\*152)



**MS-TDCB6**  
吹吸风烫台  
Vacuum & Blowing Ironing Table



**MS-TD(Z)S-BI**  
伺服变频烫台  
Servo Frequency Conversion Ironing Table



**MS-DLD3-0.4-B1**  
3KW电加热蒸汽锅炉  
Electrically-heated Steam Boiler



**MS-DLD3-0.4-C4**  
3KW全自动电加热节能蒸汽锅炉  
Fully Automatic Electrically-heated energy-saving Steam Boiler



**MS-DLD6-0.4-E2**  
6KW全自动电加热蒸汽锅炉  
Fully Automatic Electrically-heated Steam Boiler



**MS-DLD6-12-0.4-B2**  
6KW全自动电加热蒸汽锅炉  
Electrically-heated Steam Boiler



**MS-DLD6-12-0.4-F4**  
6KW全自动电加热节能蒸汽锅炉  
Fully Automatic Electrically-Heated Energy-Saving Steam Boiler



**MS-DLD18-24-0.4-A2**  
18KW全自动电加热蒸汽锅炉  
Fully Automatic Electrically-heated Steam Boiler



**MS-LDR0.09-0.7-1**  
全自动电加热蒸汽锅炉(36/48/60/72)KW  
Fully Automatic Electrically-heated Steam Boiler



**MS-LDR0.15-0.7-1A**  
全自动电加热蒸汽锅炉(80/96/108/120)KW  
Fully Automatic Electrically-heated Steam Boiler



**MS-SZS0.015-0.1-0.4Q**  
全自动燃气锅炉  
Fully Automatic Gas-fired Steam Boiler



**MS-LNS0.1-0.8-YC**  
全自动燃气锅炉  
Fully Automatic Gas-fired Steam Boiler



**MS-W94A/94L/94B**  
吊瓶熨斗  
Gravity Bottle Iron

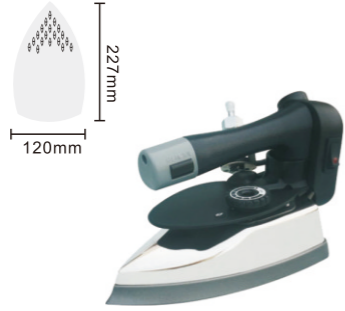

**MS-W300/300L/300B**  
吊瓶熨斗  
Gravity Bottle Iron

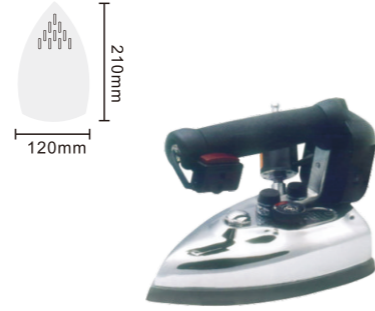

**MS-W85AF**  
吊瓶熨斗  
Gravity Bottle Iron

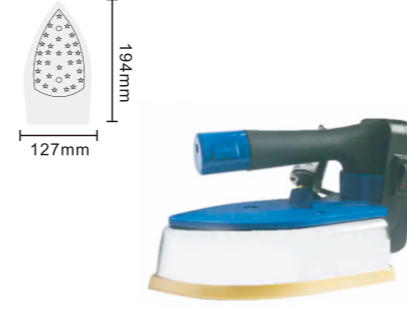

**MS-99B**  
电加热熨斗  
Electric Steam Iron

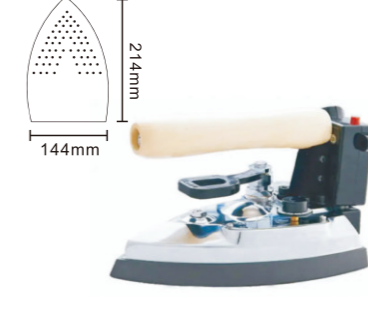

**MS-B8T**  
电加热熨斗  
Electric Steam Iron

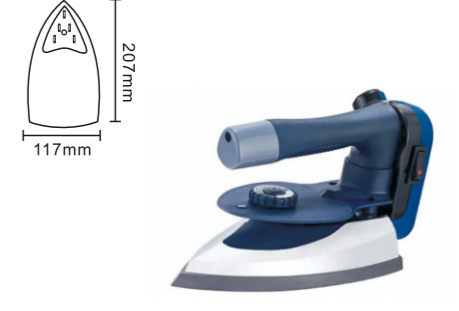

**MS-360**  
电加热熨斗  
Electric Steam Iron

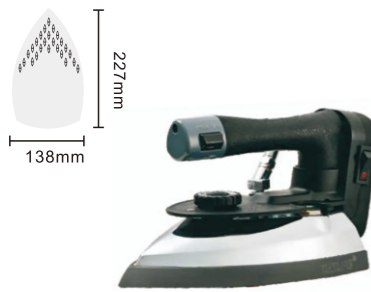

**MS-3300**  
吊瓶熨斗  
Gravity Bottle Iron

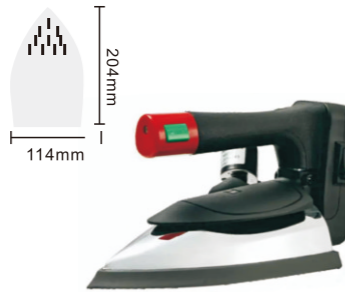

**MS-530**  
吊瓶熨斗  
Gravity Bottle Iron



**MS-533**  
吊瓶熨斗  
Gravity Bottle Iron

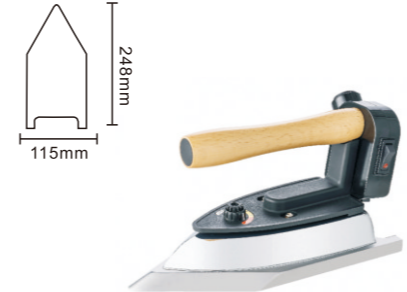

**MS-820**  
电加热熨斗  
Electric Steam Iron



**MS-W6PC**  
蒸汽熨斗  
All Steam Iron

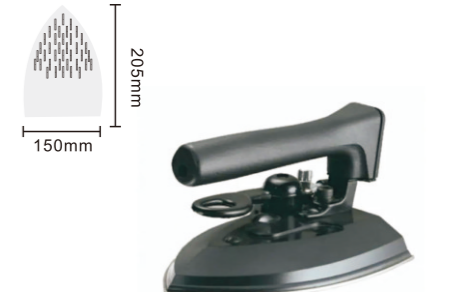

**MS-W160**  
蒸汽熨斗  
All Steam Iron

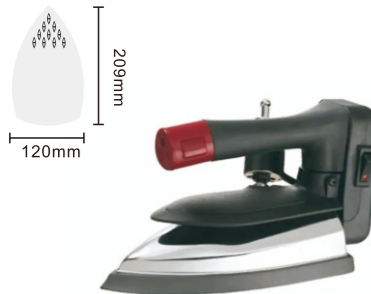

**MS-520**  
吊瓶熨斗  
Gravity Bottle Iron

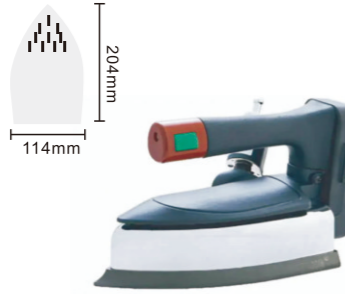

**MS-96B**  
吊瓶熨斗  
Gravity Bottle Iron



**MS-W2128**  
电加热熨斗  
Electric Steam Iron

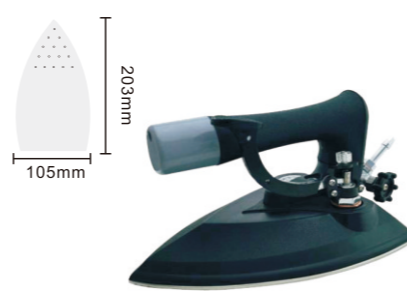

**MS-300**  
蒸汽熨斗  
All Steam Iron



**MS-15**  
蒸汽熨斗  
All Steam Iron

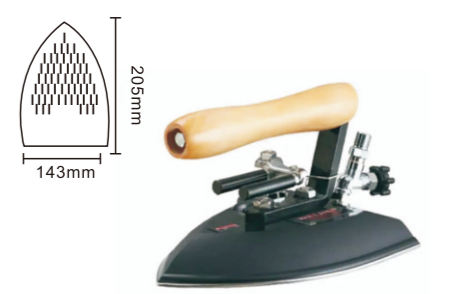

**MS-600H**  
蒸汽熨斗  
All Steam Iron

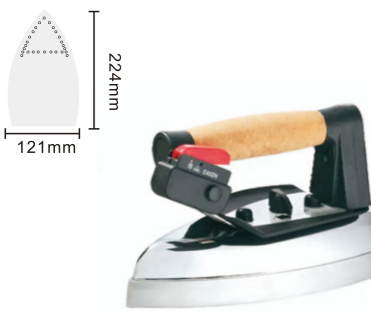

**MS-WB200**  
电加热熨斗  
Electric Steam Iron



**MS-W1000**  
电加热熨斗  
Electric Steam Iron

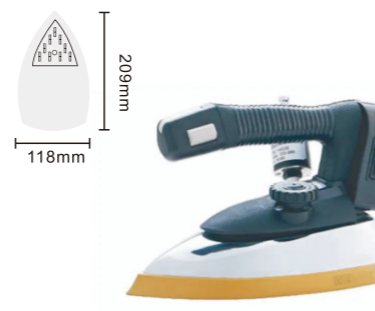

**MS-787**  
电加热熨斗  
Electric Steam Iron

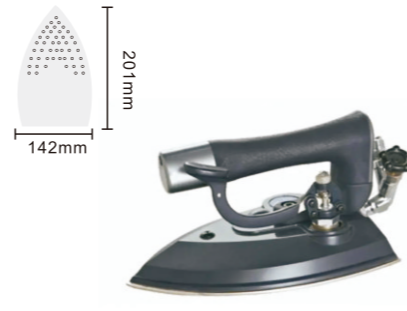

**MS-620**  
蒸汽熨斗  
All Steam Iron

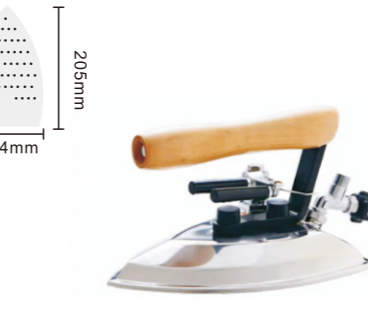

**MS-1A**  
蒸汽熨斗  
All Steam Iron

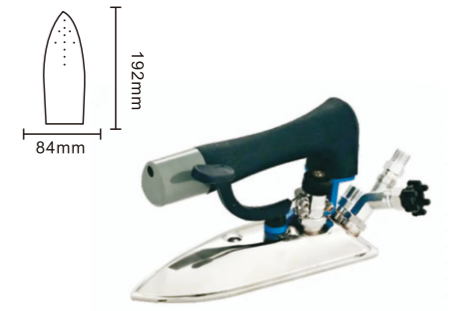

**MS-200**  
蒸汽熨斗  
All Steam Iron



**MS-75(1.8L)**  
小型电加热蒸汽锅炉熨斗  
Electric Steam Boiler With Steam Iron



**MS-2035(3.5L)**  
小型电加热蒸汽锅炉熨斗  
Small Electronic Heated Steam Boiler Iron



**MS-2002(2L)**  
小型电加热蒸汽锅炉熨斗  
Small Electronic Heated Steam Boiler Iron



**MS-2005(5L)**  
小型电加热蒸汽锅炉熨斗  
Small Electronic Heated Steam Boiler Iron



**MS-2000/MS-518**  
挂烫机  
Garment Steamer



**MS-12**  
蒸汽锅炉带熨斗  
Steam Boiler With Iron



**MS-2006**  
蒸汽锅炉带熨斗  
Steam Boiler With Iron



**MS-6**  
蒸汽锅炉带熨斗  
Steam Boiler With Iron



**MS-76**  
蒸汽锅炉带熨斗  
Steam Boiler With Iron

Model	Voltage	Boiler poweriron	Iron power	Water capacity	Packing Size
MS-2006	220v/110v	2200w	900w	5L	595x385x335mm
MS-6	220v/110v	1600w	900w	4L	355x315x525mm
MS-76	220v/110v	1600w	900w	2L	480x305x390mm

## Other Equipment Machine Series

其他设备系列

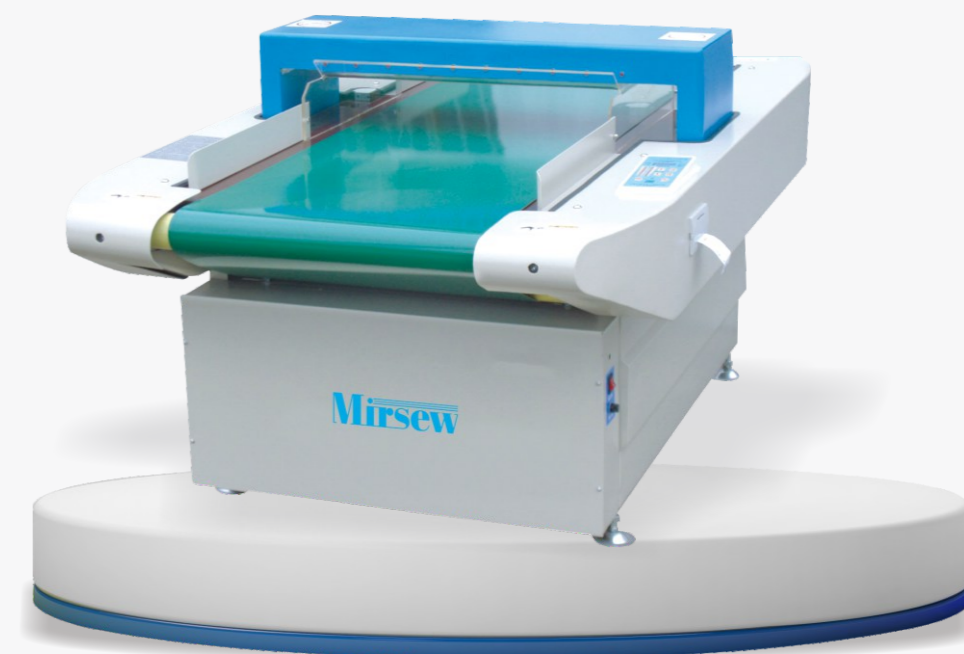

**MS-200MS/450MS/500MS/600MS**

自动调偏型粘合机 (无缝带)  
Auto-Belt Adjustment Fusing Machine (Seamless Belt)



1. It is equipped with automatic snake correction device;
2. The upper and lowerbelts adopt Cam Direct deviation adjusting device to keep the belt in a stable position;
3. Open design is adopted on one side, which can be partially bonded. The driving roller is improved into a rubber shaft;
4. MS standard assembly has rotary stripping device.

**MS-H400/H500/H600/H800**

强制防偏型粘合机 (有缝带)  
Forced Anti-Deviation Fusing Machine (With Seam Belt)



1. It is equipped with forced correction device;
2. With imported seam conveyor belt , the motor has high horsepower and the working efficiency is twice as high as that of similar machines;
3. With up and down heating temperature control regulator (optional), can bear bitrarily adjusted in the range of 0-220 C;
4. Double and single side pressing lining (optional);
5. Unique electronic temperature regulation and direct sensor can control tiny temperature difference;
6. It has automatic temperature shutdown function and hand-operated power cut mechanism.

**MS-H900/H1000/H1200**

强制防偏型粘合机 (有缝带)  
Forced Anti-Deviation Fusing Machine (With Seam Belt)



It can be widely used in various non-flammable agents contain fabric collar, chest, cuffs, placket, waist top fabric and adhesive products smooth stiff and resistant to washing, easy trend, it applicable to all resins collar lining.



Model	Voltage v	Heating power kw	Motor w	Operating temperature °C	Pressure kg/cm²	Belt speed m/min	Fusing width mm	Packing size mm	Nw/gw kg
MS-200MS	220/380	2	40	50-200	0-4.5	0-8	200	930x1080x950	130/180
MS-450MS/H400	220/380	4.5	40	50-200	0-4.5	0-8	450	1065x1080x950	140/190
MS-500MS/H500	220/380	5	40	50-200	0-4.5	0-8	500	1165x1080x950	150/200
MS-600MS/H600	220/380	6	60	50-200	0-4.5	0-8	600	1265x1080x950	170/220
MS-H800	220/380	8	80	50-200	0-4.5	0-8	800	1365x1080x950	190/240
MS-H900	3P 220/380	22	90	50-200	0-5	0-12	900	3560X1480X1470	
MS-H1000	3P 220/380	24	100	50-200	0-5	0-12	1000	3560X1780X1470	
MS-H1200	3P 220/380	26	120	50-200	0-5	0-12	1200	3560X2080X1470	

**MS-630-12P/15P/20P/25P**

单探头检针机系列  
Single Probes Anti-Jamming Needle Detector



1. With advanced CPU program master control system, it can automatically control the size of induction model;
2. CPU make scor responding actions (alarms) according to the testing standards required by customers;
3. It has the function of printing and output in English in the test report;
4. The tape of EPSON printing head of Weihuang printer can be printed, and the data can be saved for along time (optional);
5. It has the function of timely clock and automatic shutdown without checked objects in 10 minutes under automatic condition, so as to achieve the function of power saving and safety protection;
6. In the integrated chip part, the famous foreign company brand chips are used to ensure that the machine works steadily fora long time;
7. Intelligent counter digital display, automatically record the number of qualified and unqualified items.

**MS-630B-12P/15P/20P/25P**

双探头检针机系列  
Double Probes Full Automatic Conveying Series Needle Detector



Even the smallest needle tip can be detected

**MS-20MJ**

手动检针机系列  
Manual Needle Detector Series



Model	MS-630-12P/15P/20P/25P	MS-630B-12P/15P/20P/25P
Detecting capability	600mm(W)x100mm~200mm(H)	600mm(W)x100mm~200mm(H)
Detecting sensitivity	Fe 0.8mm-1.2mm	Fe 0.8mm-1.2mm
Detecting method	Magnetic induction	Magnetic induction
Operating method	Touch type	Touch type
Power requirements	AC220V+100%	AC220V+100%
Power consumption	100w	200w
Volume	1850mm(L)x 1050mm(W) x 900mm ~1000mm(H)	2300mm(L)x 1050mm(W) x 900mm

**MS-614B(624B/714B/724B/728B)**

充棉机系列  
Intelligent Down & Cotton Filling Machine Series



1. With a triple weighing system used, the speed of down-filling machine is 2-4 times faster than that of manual method; Down-filling is no longer needed skilled workers;
2. Non-contact weighing method is used;
3. According to given target gram weight the actual down gram weight will be automatically increased or reduced as necessary during filling;
4. The patented design of down outlet resolves the filling problems of airtight fabrics and special soft fabrics;
5. The range of single time\*0.2-32q, capable of filling both large and small lattice panels;
6. The user friendly touch screen design, can be stored at any time, can be called at any time to change the data.

Filling Speed : 1g/s~8g/s(adjustable)  
Single Down Loading Volume : 8kg~15kg approximately(duck down)  
Filling Requirement: 90, 80, 70, 60 down, dry  
Machine Accuracy : 2%(90 down under standard environment testing)



**MS-1101GA**  
半自动充棉机  
Semi-Automatic Cotton Filling Machine Series



**MS-220L**  
2口流量填充机  
Auto Flow Filling Machine

Product model	614B	1101GA	220L
Filling port	1	1	2
Number of scales	4	1	
Bucket capacity for down	N/A		
Bucket capacity for cotton	3-200g	10-100g	
Maximum accuracy	0.1g	0.1g	
Storage capacity	15Kg		10Kg
Input voltage	4P 380V AC	1P 220V AC	4P 380V AC
Power rating	3.1kW	0.05KW	3.0KW
Input pressure	0.55~0.5mpa	0.55~0.8MPa	0.55~0.8MPa
Storage box size	1.7x1.1x1.9m	1.2x0.65x0.95m	1.5x0.85x1.8m
Weighing box size	1.7x0.9x1.5m		
Work desk size	N/A		
Fan size	0.6x0.6x0.7m		0.55x0.48x0.6m
Min footprint size	2.2x2.5m	1.5x2.0m	2.2x1.2m
Suggested site size	2.5x3.5m	2x2.5m	3.0x2.0m



**MS-GT22-12**  
直驱伺服微油衣车台式剪线机  
Direct Drive Servo Micro Oil Coating Truck Desktop Thread Trimming Machine



**MS-GT12-AT**  
自动感应气动吸风剪线机(可搭配各类缝纫机)  
Automatic Induction Pneumatic Suction Thread Trimming Machine (For various Sewing Machines)

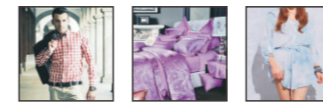

**MS-GT26-12**  
直驱伺服微油衣车台式手提剪线机  
Direct Drive Servo Micro Oil Coating Truck Desktop Portable Thread Trimming Machine



**MS-GT26-3**  
裤板型剪线机  
Trousers Board Type Thread Trimming Machine



**MS-TC-02**  
手提式剪线机  
Portable Thread Trimmer Machine



**MS-560A/B**  
吸线头机  
Thread Sucking Machine



**MS-60A**  
二氧化碳激光打标机  
Carbon Dioxide Laser Marking Machine



**MS-12P**  
紫外线激光打标机  
UV Laser Marking Machine



**MS-C38**  
大贝型饰边包缝机  
Large Shell Stitch Overlock Sewing Machine



**MS-C38L**  
中贝型饰边包缝机  
Medium Crochet Stitch Overlock Sewing Machine



**MS-C17**  
中贝型饰边包缝机  
Medium Shell Stitch Overlock Sewing Machine



**MS-LT1080**  
剪裤耳机  
Cut Pants Headphones

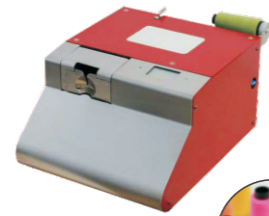

**MS-LT80**  
自动加固绕纽扣机  
Automatic Reinforcement Button Winding Machine

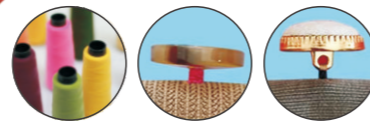

**MS-C18**  
“E”字形饰边包缝机  
“E” Font Stitch Overlock Sewing Machine



**MS-C1-2**  
毛毯锁边机  
Blanket Overlock Sewing Machine



**MS-300U-1CS**  
单针综合床垫围边机  
Compound Feed For Sewing Mattress Tape Edge(Single Needle)



**MS-20C**  
分线机  
Thread Distributor Machine



**MS-40C**  
分线机  
Thread Distributor Machine



**MS-20S**  
分线机  
Thread Distributor Machine

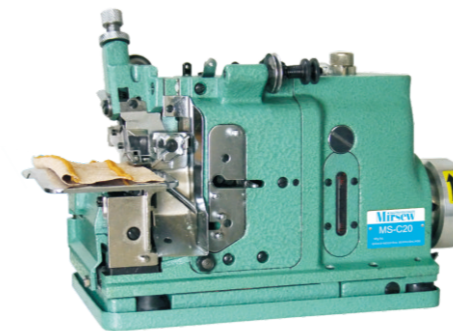

**MS-C20**  
鱼骨刺拼缝拷克机  
Fishbone Stitching Machine

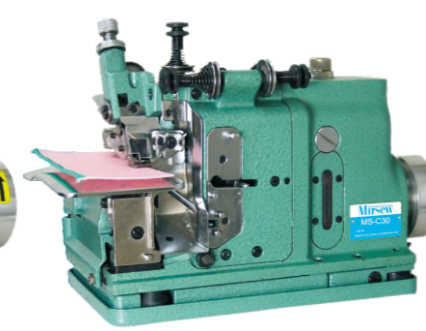

**MS-C30**  
臂章包边机  
Emblem Overedging Sewing Machine

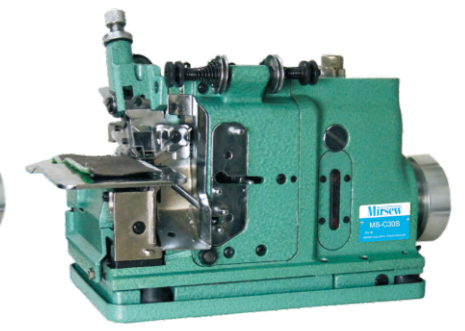

**MS-C30S**  
小贝壳饰边包缝机  
Shell Stitch Overlock Sewing Machine

Model	Voltage	Frequency	Power	Air pressure	Productivity	Thread consumption	Gross weight	Packing size
MS-LT80	220/110v	50/60hz	60w	0.5-0.6Mpa	1000~1500buttons/h	3500~5000buttons/h	15kg	470x390x340mm

Model	Power	Air pressure	Productivity	Thread consumption	Gross weight	Packing size
MS-20C	2	110/220V	510x495x355	24/26		
MS-40C	4	110/220V	710x495x355	24/26		
MS-20S	2	110/220V	550x300x355	17/18		

Model	Needle	Stitch range	Seam width	Speed	Motor	Packing size	GW/NW
MS-C38	DBX1 #21-24			1200rpm	370/250	380x250x400mm	19/17kg
MS-C27	DBX1 #21-24			1200rpm	370/250	380x250x400mm	19/17kg
MS-C17	DBX1 #21-24			1200rpm	370/250	380x250x400mm	19/17kg
MS-C18	DBX1 #21-24	2.5-10mm	10mm	1200rpm	370/250	380x250x400mm	18/16kg
MS-C1-2	G01-2x160-200	5-10mm	10mm	1000rpm	370/250	380x225x320mm	17/15kg
MS-C20	151x7/TL/7		0.8-5mm	3500rpm	370/250	410x370x360mm	18/16kg
MS-C30	151x7/TL/7		3-6mm	4500rpm	370/250	410x370x360mm	18/16kg
MS-C30S	151x7/TL/7		5mm	4000rpm	370/250	410x370x360mm	18/16kg



**MS-26-1A**  
手提封包机  
Portable Bag Closer Machine



**MS-GK9-900A-36V**  
手提封包机  
Portable Bag Closer Machine



**MS-GK9-370-36V**  
手提封包机  
Portable Bag Closer Machine



**MS-1900DPH**  
上位机喷墨绘图机  
Upper Computer Inkjet Plotter

45 double inkjet printer, using the world's 45 type ink cartridge, the nozzle is disposable ink cartridge. High performance ARM processor is adopted, which is fast in calculation. Combined with the special high-speed motor drive control system, the whole process closed-loop positioning has high control precision, fast running speed, high resolution, and is not affected by complicated and simple graphics lines, and the speed is uniform. Automatic online automatic printing, real-time monitoring of various operating conditions. With independent output management system, it can connect various CAD software standard files.



**MS-35-1**  
封包缝纫机  
Bag Sewing Machine



**MS-35-2C**  
高速封包缝纫机  
High Speed Bag Closer Machine



**MS-309**  
地毯锁边机  
Three Threads Carpet Serger

SMITTE Vertical inkjet plotter adopts the world-wide hp45 type ink cartridge, and the ink head is disposable. It adopts high-performance ARM processor with fast operation combined with the special high-speed motor drive control system. It has the advantages of whole process closed-loop positioning, high control precision, fast operation speed, high resolution, not affected by the complexity of graphics and lines, and uniform speed. Automatic online printing: Monitor various operating conditions in real time. It has an independent output management system, which can connect various CAD software standard files.



**MS-1900APH**  
伺服高速喷墨绘图机  
Servo High Speed Inkjet Plotter



**MS-20-2**  
单针包边缝纫机  
Overedging Machine



**MS-8-2**  
高速缝包缝纫机  
High Speed Bag Closer Machine



**MS-81300A1H**  
双针四线上下送料包边链锁缝包机  
Double Needle Four Thread Top And Bottom Feed Hemming Chain Lock Sewing Machine



**MS-1800APQ**  
立式喷切一体机  
Vertical Inkjet And Cutting Plotter

Schmidt jet cutting machine is a multifunction machine with marks, frames and samples. It adopts hp45 type ink cartridge which is universal in the world. The ink head is disposable and does not need special maintenance. It has intelligent electronic spring cutter control system, precise cutting, smooth cutting, special circuit and motor drive system, which ensures stable continuous operation, large screen ICD display, Chinese panel, real-time operation. Simple and precise operation.

Model	Voltage	Power	Packing width	Sealing speed	Thickness	Weight	Packaging size
MS-26-1A	110v/220v	0.09kw	1000	1700	8mm	5kg	370x370x270mm
MS-GK9-900A-36V	36v	0.19kw				2.5kg	250x240x80mm
MS-GK9-370-36V	36v	0.19kw				2.5kg	250x240x80mm
MS-35-1	220v/380v	0.75kw	1000	2000	8mm	32kg	460x358x540mm
MS-20-2		0.37kw	8-16		10mm	35kg	445x245x375mm

Model	MS-1900DPH	MS-1900APH	MS-1800APQ
Max Printing Width	1900mm	1900mm	1800mm
Medium Width	1200~1900mm	1200~1900mm	1200~1900mm
DPI	150-600DPI	150-600DPI	150-600DPI
Command Format	HP-GL	HP-GL	HP-GL
Input Voltage	AC90-260V/50-60Hz	AC90-260V/50-60Hz	AC220V/60Hz ≥600w
Machine size(LxWxH)	2500x590x1030mm	2500x590x1030mm	2500x590x1030mm
Packing size(LXWxH)	2575x610x660mm	2575x610x660mm	2575x610x660mm



Thick and thin T-shirts, sweaters, jackets, warm clothes, knitwear shirts, coats, trousers, etc.



**MS-GM500-HG**

全自动薄料折叠装袋热切封口包装机(基础款)  
Automatic Thin Material Folding, Bagging, Hot Sealing And Packaging Machine (basic)



Packaged products



**MS-GM511-E**

全自动导入厚薄料折叠装袋撕胶封口(基础款)  
Automatic Import Of Thick And Thin Materials, Folding, Bagging, Tearing And Sealing (basic)



Vltage:220VAC  
Power:0.2KW  
Machine size:L1220xW950xH900cm  
Air pressure: 0.5-0.7Mpa  
Packaging speed:<400 Pieces/hour

**MS-GM100**

自动折叠衣服包装机  
Automatic Folding Clothes Packaging Machine



**MS-GM200**

自动服装折叠&装袋机  
Automatic Garment Folding & Baging Machine

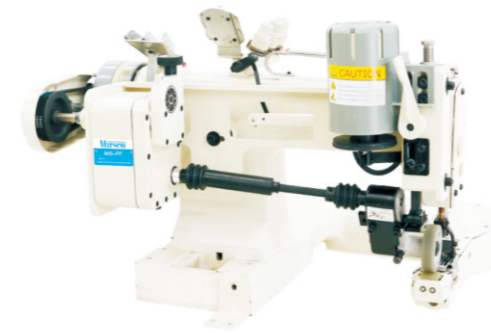
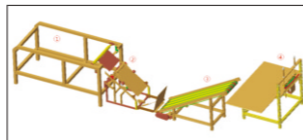

**MS-PF**

曲腕机专用  
For Feed-Off Arm Machine



**MS-PF-HB**

曲腕机专用(履带式)  
For Feed-Off Arm Machine



**MS-PK**

包缝机专用  
For Overlock Machine

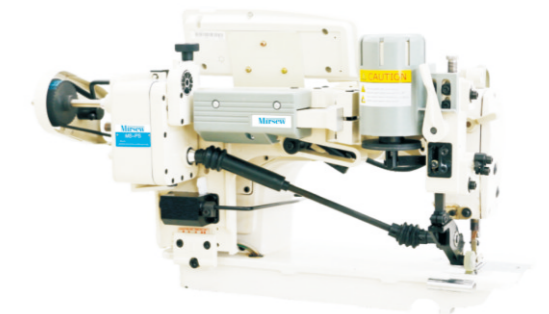

**MS-PS**

单/双针专业直径(25mm,宽10mm)  
For Single/Double Needle Machine(Diameter 25mm,Width 10mm)

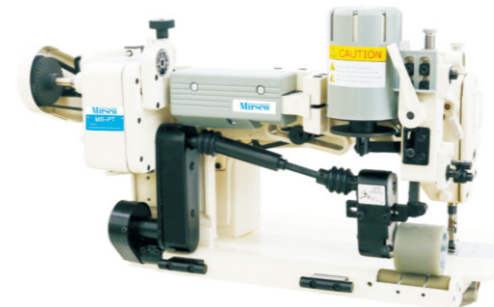

**MS-PT**

单双针专用(上拖轮)  
For Single/Double Needle Machine(Top Puller)

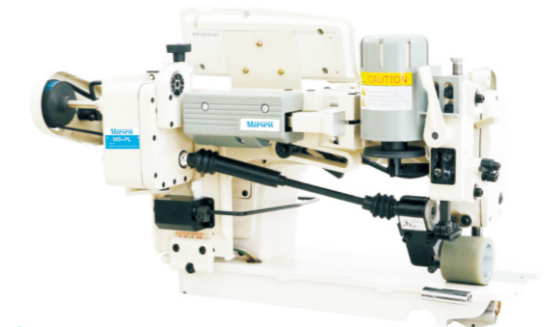

**MS-PL**

单/双针专业直径55mm,宽15/35/50mm  
For Single/Double Needle Machine(Diameter 55mm,Width 15/35/50mm)

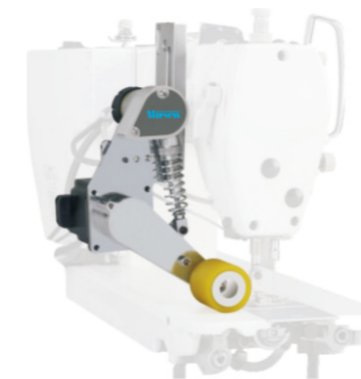

**MS-6G**

电子拖轮  
Electronic Pulley



**MS-MC-QF**

微电脑文胸接耳仔装置  
Micro-Computer Bra Swan-Woock Attachment Device

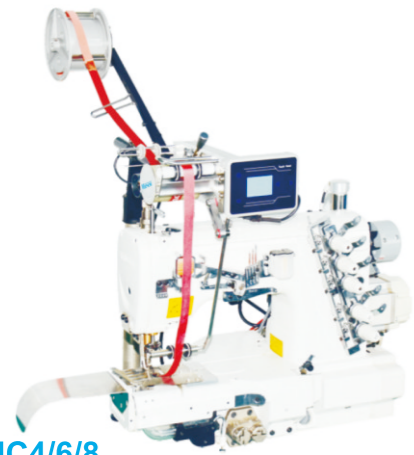

**MS-MC4/6/8**  
微电脑触摸屏送带机 (4、6、8段)  
Micro-Computer All-Round Metering Device(4/6/8 Sections)



**MS-MC2-U**  
辅助装置  
Assisting Device



**MS-120/135**  
电机  
Phase Clutch Motor



**MS-550S**  
伺服下挂电机  
Electronic Adjustable-Speed Servo Motor

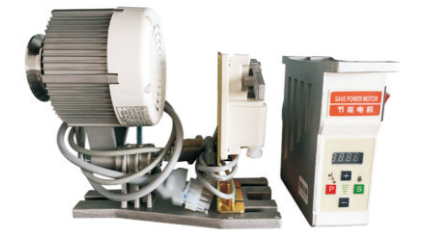

**MS-550/750N**  
伺服下挂电机  
Electronic Adjustable-Speed Servo Motor

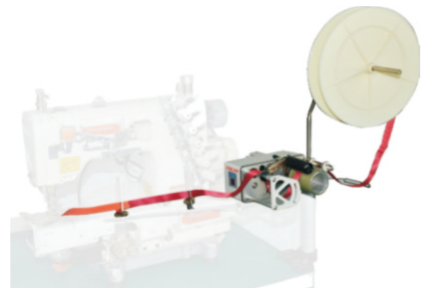

**MS-MC2-S**  
数码同步送带装置  
Digital Synchronous Metering Device



**MS-MC-20K**  
微电脑送切带控制装置  
Computer Cutting & Re-insert Elastic Control Device



**MS-DD1**  
平缝机直驱电机  
Single Direct Drive Motor For Industrial Sewing Machine



**MS-T05**  
平缝机多功能直驱电机  
Electronic Full Function Servo Motor



**MS-WR595**  
多功能平缝机电机  
Electronic Full Function Servo Motor



**MS-MDK61**  
包缝机同步装置 (专用型)  
For Special Overlock Machine



**MS-MDK60**  
包缝机同步装置 (通用型)  
For General Overlock Machine



**MS-M1N**  
包缝机直驱电机  
Direct Drive Motor For Overlock Sewing Machine



**MS-M25**  
包缝机多功能直驱电机  
Multifunctional Direct Drive Motor For Overlock Sewing Machine



**MS-35**  
细缝机多功能直驱电机  
Multifunctional Direct Drive Motor For Interlock Sewing Machine

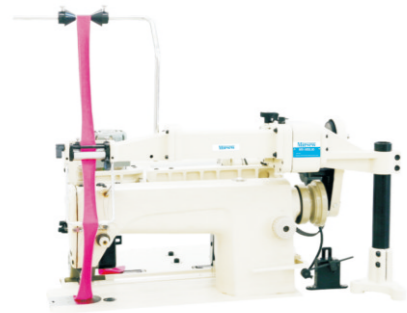

**MS-MDL30**  
平车、双针、绷机用  
For Single, Double Needle, Coverstitch, Special Machine

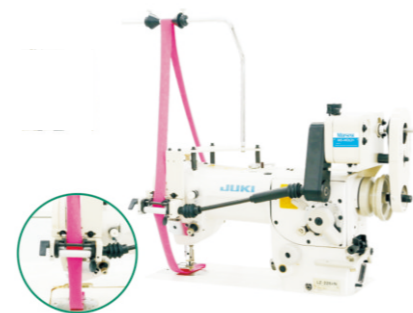

**MS-MDL31**  
高速曲折缝车专用  
Meteeing Device For Zigzag Machine



**MS-S3-M3**  
直驱伺服电机 (多功能型)  
Multi-Function Direct Drive Servo Motor



**MS-SD85-KD300**  
伺服电机 (特厚料专用)  
Servo Motor (Special For Extra Thick Materials)



**MS-H600**  
伺服电机  
Servo Motor