



MAYSUN SOLAR FZCO

INSTALLATION MANUAL

IEC & MCS version

Maysun solar Module model MONO 1956*992*40mm	MSXXM-72	Wp325
	MSXXM-72	Wp330
	MSXXM-72	Wp335
	MSXXM-72	Wp340
	MSXXM-72	Wp345
	MSXXM-72	Wp350
	MSXXM-72	Wp355
	MSXXM-72	Wp360
	MSXXM-72	Wp365
	MSXXM-72	Wp370
	MSXXM-72	Wp375
	MSXXM-72	Wp380
	MSXXM-72	Wp385
	MSXXM-72	Wp390
	MSXXM-72	Wp395
Maysun solar Module model MONO 1650*992*35mm	MSXXM-60	Wp270
	MSXXM-60	Wp275
	MSXXM-60	Wp280
	MSXXM-60	Wp285
	MSXXM-60	Wp290
	MSXXM-60	Wp295
	MSXXM-60	Wp300
	MSXXM-60	Wp305
	MSXXM-60	Wp310
	MSXXM-60	Wp315
	MSXXM-60	Wp320
	MSXXM-60	Wp325
	MSXXM-60	Wp330
Maysun solar Module model MONO 1480*670*35mm	MSXXM-36	Wp150
	MSXXM-36	Wp160
	MSXXM-36	Wp170
	MSXXM-36	Wp180
	MSXXM-36	Wp190
Maysun solar Module model POLY 1956*992*40mm	MSXXP-72	Wp300
	MSXXP-72	Wp310
	MSXXP-72	Wp315
	MSXXP-72	Wp320
	MSXXP-72	Wp325
	MSXXP-72	Wp330
	MSXXP-72	Wp335
MSXXP-72	Wp340	
Maysun solar Module model POLY 1640*992*35mm	MSXXP-60	Wp250
	MSXXP-60	Wp260
	MSXXP-60	Wp265
	MSXXP-60	Wp270
	MSXXP-60	Wp280
Maysun solar Module model POLY 1480*670*35mm	MSXXP-36	Wp150
	MSXXP-36	Wp160
	MSXXP-36	Wp170

Maysun solar Modules 6" Half-Cell MONO 2008*1002*35mm	MSXXM-72H	Wp350
	MSXXM-72H	Wp355
	MSXXM-72H	Wp360
	MSXXM-72H	Wp365
	MSXXM-72H	Wp370
	MSXXM-72H	Wp375
	MSXXM-72H	Wp380
	MSXXM-72H	Wp385
	MSXXM-72H	Wp390
	MSXXM-72H	Wp395
Maysun solar Modules 6" Half-Cell MBB MONO 2008*1002*35mm	MSXXMB-72H	Wp385
	MSXXMB-72H	Wp390
	MSXXMB-72H	Wp395
	MSXXMB-72H	Wp400
	MSXXMB-72H	Wp405
	MSXXMB-72H	Wp410
Maysun solar Modules 6" Half-Cell MONO 1684*1002*35mm	MSXXM-60H	Wp290
	MSXXM-60H	Wp295
	MSXXM-60H	Wp300
	MSXXM-60H	Wp305
	MSXXM-60H	Wp310
	MSXXM-60H	Wp315
	MSXXM-60H	Wp320
	MSXXM-60H	Wp325
Maysun solar Modules 6" Half-Cell MBB MONO 1684*1002*35mm	MSXXMB-60H	Wp320
	MSXXMB-60H	Wp325
	MSXXMB-60H	Wp330
	MSXXMB-60H	Wp335
	MSXXMB-60H	Wp340
	MSXXMB-60H	Wp345
Maysun solar Modules 6" Half-Cell POLY 1684*1002*35mm	MSXXP-60H	Wp285
	MSXXP-60H	Wp290
	MSXXP-60H	Wp300
	MSXXP-60H	Wp305
	MSXXP-60H	Wp315
Maysun solar Modules 6" Half-Cell MBB POLY 2008*1002*35mm	MSXXP-72H	Wp340
	MSXXP-72H	Wp345
	MSXXP-72H	Wp350
	MSXXP-72H	Wp355
	MSXXP-72H	Wp360
	MSXXP-72H	Wp365
	MSXXP-72H	Wp370
	MSXXP-72H	Wp375

MAYSUN SOLAR FZCO

Tel: +971 48806872 Fax: +971 48807327 Email: info@maysunsolar.com Website: www.maysunsolar.com
Address: No.FZS2AB01 Jebel Ali, Dubai, United Arab Emirates P.O.Box:263910A



Table of Content

1. DISCLAIMER OF LIABILITY	- 3 -
2. SAFETY PRECAUTIONS	- 3 -
3. UNPACKING AND STORAGE	- 5 -
3.1 PRODUCT IDENTIFICATION	- 5 -
4. ENVIRONMENTAL CONSIDERATIONS	- 5 -
4.1 CLIMATE CONDITIONS	- 5 -
5. SITE SELECTION	- 6 -
6. MOUNTING INSTRUCTIONS	- 6 -
6.1 MOUNTING METHODS	- 6 -
A. Mounting with Bolts	- 6 -
B. Mounting with Clamps	- 7 -
6.2 GROUNDING	- 10 -
6.3 MODULE WIRING	- 12 -
7. ELECTRICAL CONFIGURATION	- 13 -
7.1 FUSING	- 13 -
7.2 INVERTER SELECTION AND COMPATIBILITY	- 13 -
8. MAINTENANCE AND CARE	- 14 -
9. WARNING	- 15 -



1. DISCLAIMER OF LIABILITY

The installation, handling and use of Maysun Solar crystalline modules are beyond company control. Maysun Solar does not assume any responsibility for loss, damage, injury or expense resulting from the improper installation, handling, use or maintenance.

Maysun Solar assumes no responsibility for any infringement of patents or other rights of third parties that may result from use of the module. No license is granted by implication or under any patent or patent rights. Specifications included in this manual are subject to change without prior notice.

2. SAFETY PRECAUTIONS

Potentially lethal DC voltages can be generated whenever PV Modules are exposed to a light source, therefore, avoid contact with electrically active parts and be sure to isolate live circuits before attempting to make or break any connections.

When working on electrical connections, remove all metallic jewelry, use properly insulated tools and wear appropriate personal protective equipment to reduce the risk of electric shock.

Do NOT stand or step on, damage or scratch the front or backside surfaces of the module.

Broken modules cannot be repaired and contact with any module surface or frame can lead to electrical shock.

Do NOT use a module with broken glass or torn substrate.

Do NOT disassemble the modules or remove any part of the module.

Protect the electrical plug contacts against corrosion and soiling. Make sure that all connectors are corrosion free and clean before making the connection.

Do NOT install or handle modules when they are wet or during periods of high wind.

Ensure that all connections are securely made with no gap between the contacts. Any gap can result in electrical arcing that can cause a fire hazard and/or an electric shock.

Make sure that the polarity of each module or a string is not reversed considering the rest of the modules or strings.

Do NOT artificially concentrate sunlight on these solar modules.

Do NOT use water to extinguish fires of an electrical origin.

Do NOT walk on the modules.

Do NOT disconnect the modules under load to avoid arcs and electrical shocks. If needed cover the module surface with an opaque cover.

Any module or panel mounting system has limitations on specific inclination required to maintain a specific System Fire Class Rating.

Where common grounding hardware (nuts, bolts, star washers, split-ring lock washers, flat washers and the like) is used to attach a listed grounding/bonding device, the attachment must be made in conformance with the grounding device manufacturer's instructions.

Common hardware items such as nuts, bolts, star washers, lock washers and the like have not been evaluated

for electrical conductivity or for use as grounding devices and should be used only for maintaining mechanical connections and holding electrical grounding devices in the proper position for electrical conductivity. Such devices, where supplied with the module and evaluated through the requirements in IEC61730 61215, may be used for grounding connections in accordance with the instructions provided with the module.

Rated electrical characteristics are within ± 10 percent of measured values at Standard Test Conditions of 1000 W/m², 25°C cell temperature and AM 1.5 solar spectral irradiance.

The fire rating of Maysun Solar PV module is valid only when mounted in the manner specified in the mechanical mounting instructions of this installation manual.

The module is considered to be in compliance with IEC61730 61215 only when the module is mounted in the manner specified by the mounting instructions below.

MAYSUN SOLAR FZCO

Tel:+971 48806872 Fax:+97148807327 Email:info@maysunsunsolar.com Website:www.maysunsolar.com
Address: No.FZS2AB01 Jebel Ali, Dubai, United Arab Emirates P.O.Box:263910A



Module model	Specific construction	Marking
MSXXXM-72 MSXXXP-72	Please check the related IEC description files when checking the fire protection rank of the BOM concerned	Module Fire Performance: Type 1/ Type 2
MSXXXM-60 MSXXXP-60	Please check the related IEC description files when checking the fire protection rank of the BOM concerned	Module Fire Performance: Type 1/ Type 2
MSXXXM-36 MSXXXP-36	Please check the related IEC description files when checking the fire protection rank of the BOM concerned	Module Fire Performance: Type 1/ Type 2
All series in this description	All construction in this description	Fire resistance rating: Class C

The Type 1 and/or Type 2 modules with the specified constructions in the table below, when installed with a IEC listed mounting system that has been rated as a Class A System, is suitable to maintain the System Class A Fire Rating.

Module model	Specific construction	Marking
MSXXXM-72 MSXXXP-72	Please check the related IEC description files when checking the fire protection rank of the BOM concerned	Module Fire Performance: Type 1/ Type 2
MSXXXM-60 MSXXXP-60	Please check the related IEC description files when checking the fire protection rank of the BOM concerned	Module Fire Performance: Type 1/ Type 2
MSXXXM-36 MSXXXP-36	Please check the related IEC description files when checking the fire protection rank of the BOM concerned	Module Fire Performance: Type 1/ Type 2
All series in this description	All construction in this description	Fire resistance rating: Class C

The fire rating of the module is valid only when mounted in the manner specified in the mechanical mounting instructions .

3. UNPACKING AND STORAGE

At time of receipt, verify that the product delivered is in fact the product ordered. The product name, subname,

MAYSUN SOLAR FZCO

Tel:+971 48806872 Fax:+97148807327 Email:info@maysunsunsolar.com Website:www.maysunsolar.com
Address: No.FZS2AB01 Jebel Ali, Dubai, United Arab Emirates P.O.Box:263910A



Leave the product in its original packing box until you are ready to install.

Store packing boxes in a clean, dry area with relative humidity below 85% and ambient temperatures between -20°C and 50°C.

Do NOT stack more than the maximum amount of allowable pallets on top of each other.

At the installation site, take care to keep modules and particularly their electrical contacts clean and dry before installation. If connector cables are left in damp conditions then the contacts may corrode. Any module with corroded contacts should not be used.

If pallets are stored temporarily outside then place a protective covering over the pallet to protect it from direct weathering and do not stack more than 1 pallet high.

Two people are required to unpack the modules from the packing box, when handling modules always use both hands.

Protect the module edges for temporary storage outside the pallet.

Do NOT use a knife to cut the zip-ties, but use wire cutting pliers.

Do NOT place modules directly on top of each other. and serial number of each laminate are clearly marked on the outside of each packing box.

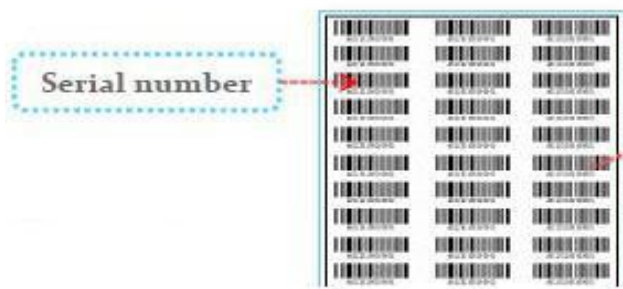

3.1 PRODUCT IDENTIFICATION

Each individual module has a unique serial number laminated behind the glass and another permanently attached to the back-sheet of the module on the product sticker. Note all serial numbers in an installation for your future records.

4. ENVIRONMENTAL CONSIDERATIONS

4.1 CLIMATE CONDITIONS

Maysun Solar Crystalline series modules may be installed in the following conditions for more than 20 years. In addition to the required IEC certification, Maysun Solar products have also been tested to verify resistance to ammonia fumes that may be present around barns sheltering cattle, as well as suitability for installation in humid (coastal) areas and areas of high sand storms.

Environment

- Ambient temperature: -40°C to 50°C
- Operating temperature: -40°C to +85°C
- Storage temperature: -20°C to +50°C
- Humidity: < 85RH%
- Mechanical Load Pressure*: 5400Pa (550 Kg/m²) Max from the front side (snow) & 2400Pa (wind) from the rear (Except Installation Method C: Mounting with Single-axis Tracking System - 2400Pa (snow) & 2400Pa

MAYSUN SOLAR FZCO

Tel: +971 48806872 Fax: +971 48807327 Email: info@maysunsolar.com Website: www.maysunsolar.com
Address: No.FZS2AB01 Jebel Ali, Dubai, United Arab Emirates P.O.Box: 263910A



(wind)

5. SITE SELECTION

Maysun Solar Modules can be mounted in landscape or portrait orientation however the impact of dirt shading the solar cells can be minimized by orienting the product in landscape.

Solar module is recommended to be installed at an optimized tilt angle to maximize the energy output. It is roughly equal to the latitude of the project site as a rule of thumb, facing to equator. But always to design based on local situations to find out the optimum one.

When installing solar modules on a roof always leave a safe working area between the edge of the roof and the external edge of the solar array.

In case of residential installations on the ground, modules shall be installed following local regulations, e.g. using fence.

Position the modules to minimize the chances of shading at any time of the day.

Do not install PV modules in a location where they will be immersed in water or continually exposed to water from a sprinkler or fountain, etc.

Avoid using a mounting method that will block the drainage holes in the module frame.

When all solar modules (except for smart module) are mounted in the same plane and orientation then all can be expected to have similar performance throughout the day and can be connected together to the same inverter channel.

If solar modules (except for smart module) on the same installation are mounted at different angles or orientations then energy production can normally be optimized by connecting the different orientations to different inverters (or different MPPT if the inverter has more than one MPPT). Refer to inverter manufacturers for further guidelines.

According to Intertek-conducted IEC 61701:2011, salt mist corrosion testing of photovoltaic (PV), Maysun Solar modules can be safely installed in corrosive salt areas within proximity of the ocean or sulfurous areas.

6. MOUNTING INSTRUCTIONS

6.1 MOUNTING METHODS

PV modules can be mounted to the substructure using either corrosion-proof M8 bolts placed through the mounting holes on the rear of the module or specially designed module clamps.

Regardless of the fixing method the final installation of the modules must ensure that:

The minimum distance between two modules is 10mm(0.4in).

The mounting method does not block the module drainage holes.

Panels are not subjected to wind or snow loads exceeding the maximum permissible loads, and are not subject to excessive forces due to the thermal expansion of the support structures.

Note: The drain holes cannot be blocked in any situation during installation or use.

A. Mounting with Bolts

The frame of each module has 4- ϕ 9*12mm mounting holes, ideally placed to optimize the load handling capability, to secure the modules to supporting structure.

To maximize mounting longevity, Maysun Solar strongly recommends the use of corrosion proof (stainless steel) fixings

Secure the module in each fixing location with an M8 bolt and a flat washer, spring washer and nut as shown in Figure 1 and tighten to a torque of 16~20 N.m(140-180lb.in.).

All parts in contact with the frame should use flat stainless steel washers of minimum 1.8mm thickness with an



outer diameter of 20-24mm(0.79-0.94in).

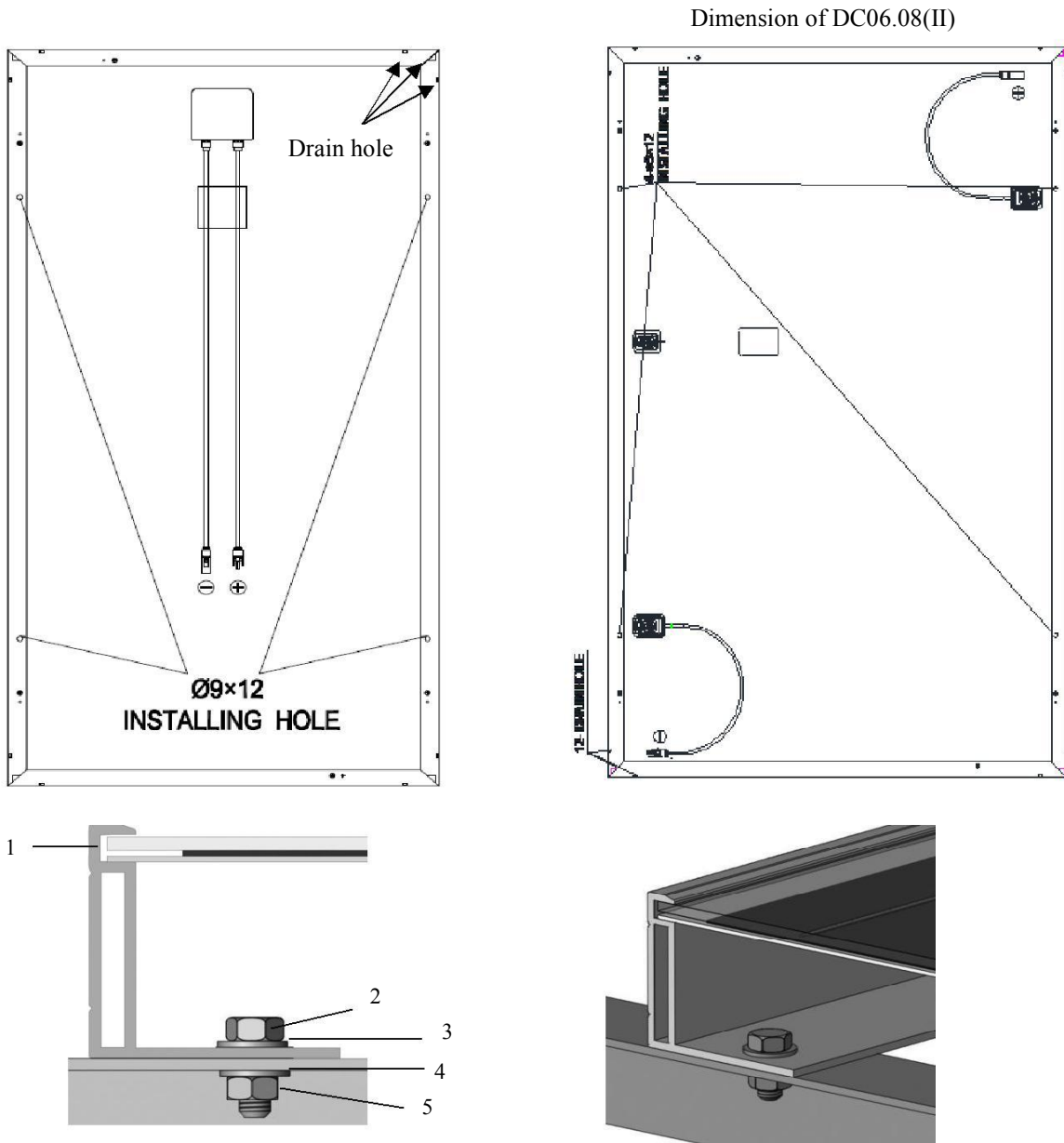

Figure 1. PV module installed with Bolt fitting method

- 1) Aluminum Frame
- 2) M8 Stainless Bolt
- 3) Flat Stainless Washer
- 4) Spring Stainless Washer
- 5) HEX Stainless Nut

B. Mounting with Clamps

MAYSUN SOLAR FZCO

Tel:+971 48806872 Fax:+97148807327 Email:info@maysunsolar.com Website:www.maysunsolar.com
 Address: No.FZS2AB01 Jebel Ali, Dubai, United Arab Emirates P.O.Box:263910A



MAYSUN SOLAR FZCO

Maysun Solar has tested its modules with a number of clamps from different manufacturers and recommends the use of clamps which have an EPDM or similar insulating washer, fixing bolt of at least M6.

The clamp must overlap the module frame by at least 7mm(0.28in) but no more than 10mm(0.39in).

Use at minimum 4 clamps to fix modules on the mounting rails.

Modules clamps should not come into contact with the front glass and must not deform the frame.

Be sure to avoid shadowing effects from the module clamps.

The module frame is not to be modified under any circumstances.

- When choosing this type of clamp-mounting method, use at least four clamps on each module, two clamps should be attached on each long sides of the module (for portrait orientation) or each short sides of the module (for landscape orientation). Depending on local wind and snow loads, additional clamps may be required to ensure that modules can bear the load.

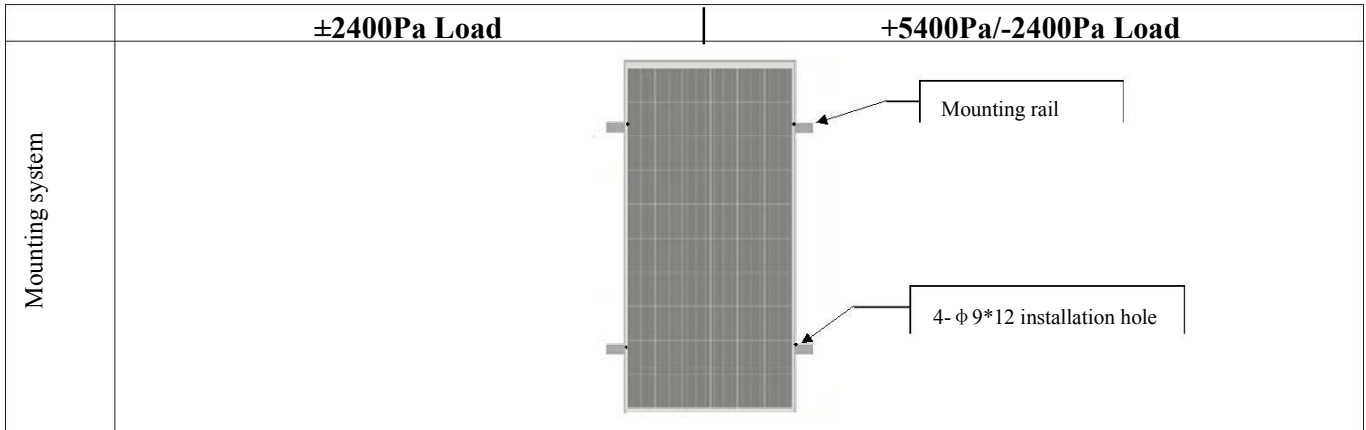
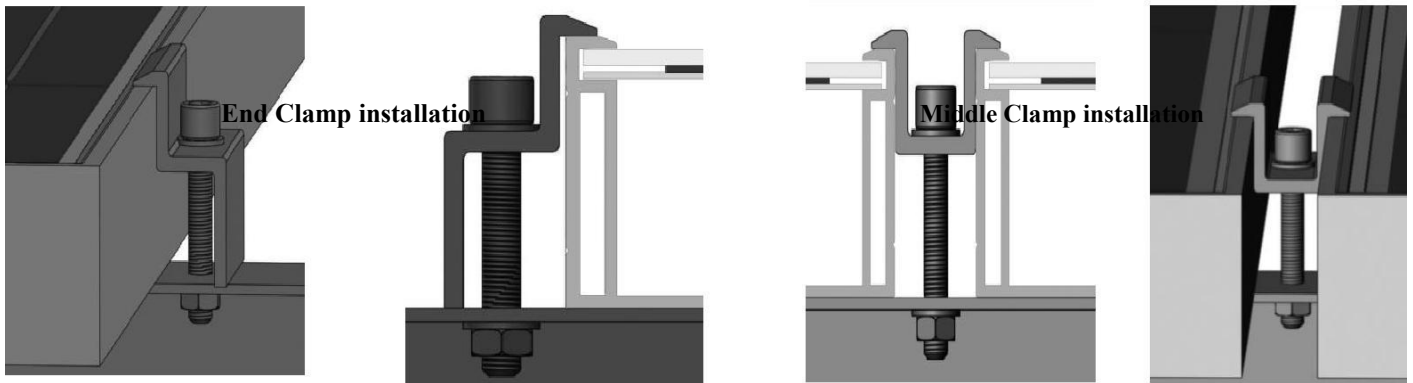

Figure 2. PV module installed with clamp fitting method

MAYSUN SOLAR FZCO

Tel:+971 48806872 Fax:+97148807327 Email:info@maysunsolar.com Website:www.maysunsolar.com
Address: No.FZS2AB01 Jebel Ali, Dubai, United Arab Emirates P.O.Box:263910A

<p>Clamping system</p>		
<p>Clamping system</p>		

C. Mounting with Single-axis Tracking System:

This installation is only for 72 cells polycrystalline modules.

It is a Single-axis Tracking System, the module is fixed on the axis by bolting long frame.

The frame of each module has 4- $\phi 7*10\text{mm}(0.28*0.39\text{in})$ mounting holes with specific location shown in Figure 3.

Secure the module in each fixing location with an M6 bolt, two flat washers, a spring washer and nut

All parts in contact with the frame should use flat stainless steel washers of minimum 1.5mm thickness with an outer diameter of 16-20mm(0.63-0.79in.).

The bolt should be made of stainless steel or the other anti-corrosion material.

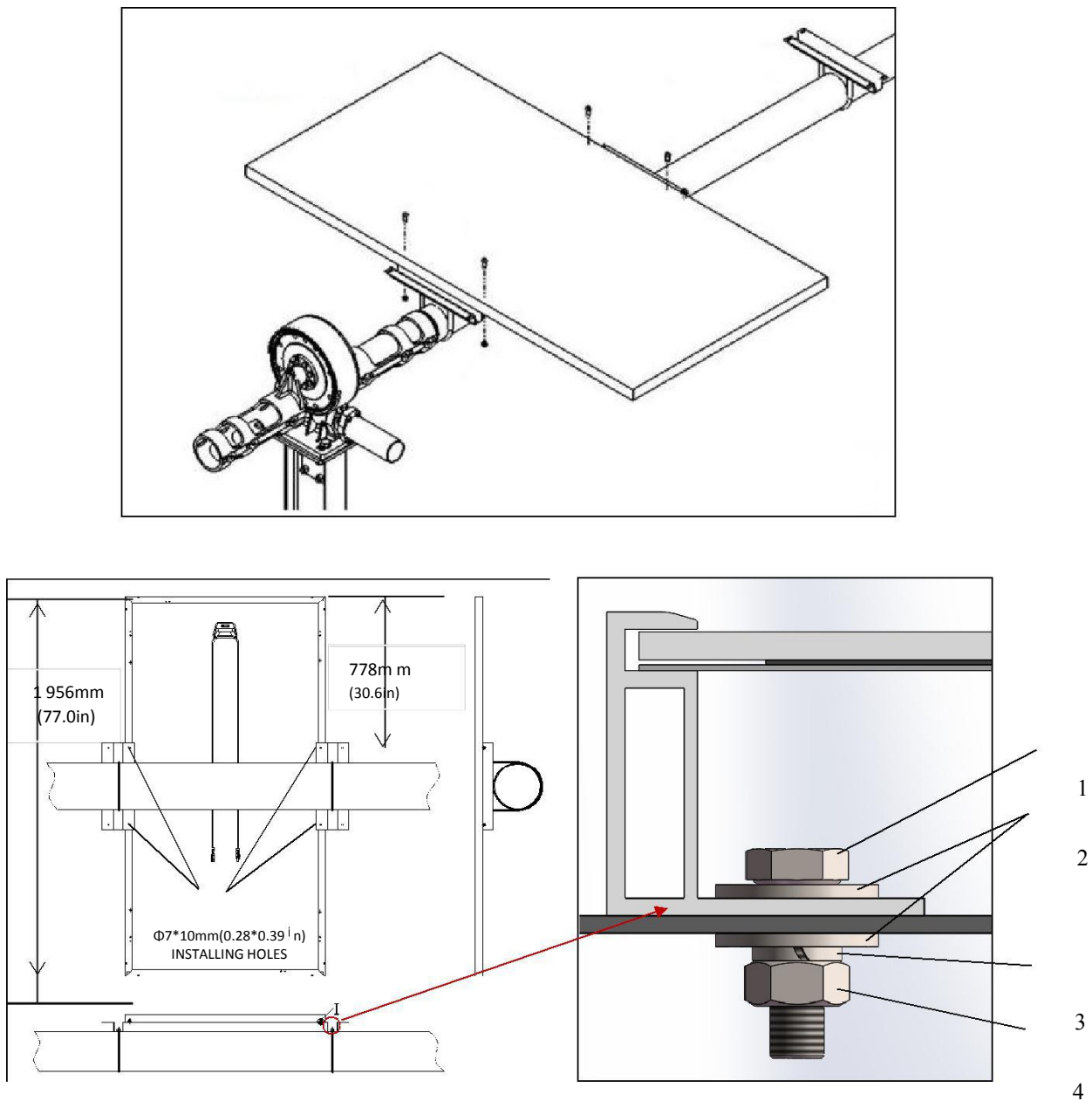

Figure 3. PV module installed with Single-axis Tracing System

- | | |
|----------------------------|--------------------------|
| 1) M6 Stainless Bolt | 2) Flat Stainless Washer |
| 3) Spring Stainless Washer | 4) HEX Stainless Nut |

6.2 GROUNDING

All module frames and mounting racks must be properly grounded in accordance with appropriate respective National Electrical Code.

Proper grounding is achieved by bonding the module frame(s) and all metallic structural members together continuously using a suitable grounding conductor. The grounding conductor or strap may be copper, copper alloy, or any other material acceptable for use as an electrical conductor per respective National Electrical Codes. The grounding conductor must then make a connection to earth using a suitable earth ground electrode.

MAYSUN SOLAR FZCO

Tel:+971 48806872 Fax:+97148807327 Email:info@maysunsunsolar.com Website:www.maysunsolar.com
Address: No.FZS2AB01 Jebel Ali, Dubai, United Arab Emirates P.O.Box:263910A



Maysun Solar modules can be installed with the use of third party listed grounding devices for grounding the metallic frames of PV modules. The devices have to be installed in accordance with the grounding device manufacturer's specified instructions.

Maysun Solar modules can be installed with the use of third party listed grounding devices for grounding the metallic frames of PV modules. The devices have to be installed in accordance with the grounding device manufacturer's specified instructions.

Please refer to the "Product Catalogue" link for detailed grounding hole location and size at www.maysunsolar.com.

Method 1: Tyco grounding bolt # 2058729-1:

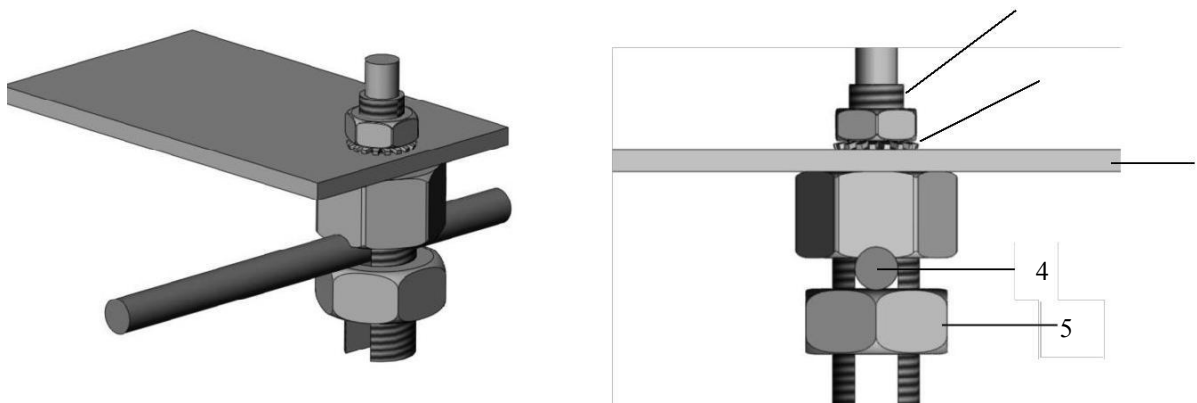

Figure 4. Tyco grounding bolt # 2058729-1
 1) Wire bolt and slot 2) Mounting wash hex nut
 3) Aluminum frame 4) 0.006 to 0.025in² cable
 5) Hex Nut

Tyco grounding hardware comes in a package that includes the grounding bolt, mounting and grounding hex nut.

Electrical contact is made by penetrating the anodized coating of the aluminum frame, and tightening the mounting hex nut (come with the star washer) to the proper torque of 25lbf.in.

Grounding wire size (6 to 12 AWG solid bare copper) should be selected and installed underneath the wire binding bolt.

The wire binding bolt should be tightened to the proper torque of 45lbf.in.

Method 2: Tyco grounding bolt #1954381-2:

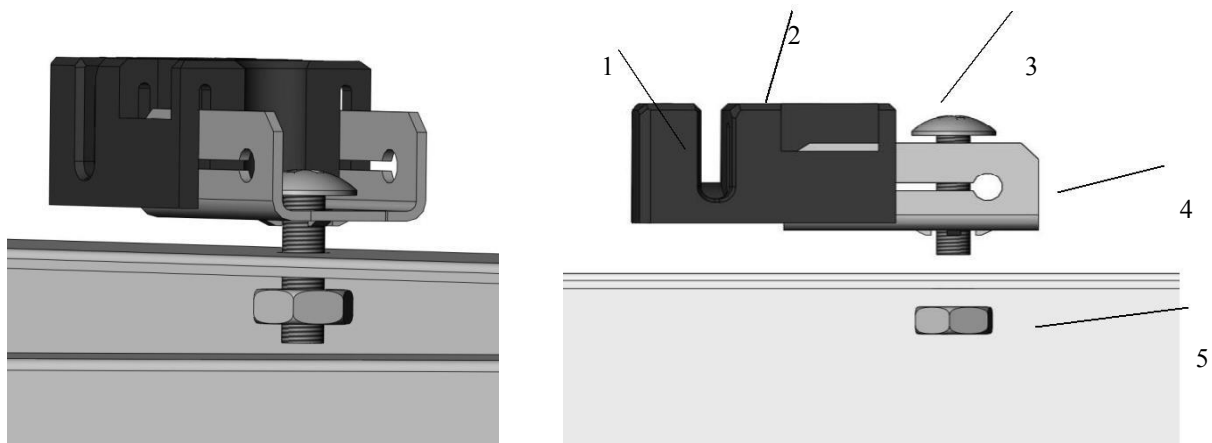



**Figure 5. Tyco grounding bolt # 1954381-2
(Not applicable for MaysunMOUNT module series)**

- | | |
|--|----------|
| 1) Wire slot (available for 0.006 to 0.025in ² cable) | |
| 3) Bolt | 2)Slider |
| 5) Nut | 4)Base |

Figure 5. Tyco grounding bolt # 1954381-2
(Not applicable for MaysunMOUNT module series)

- | | |
|---|-----------|
| 1) Wire slot (available for 0.006 to 0.025in) | 2) Slider |
| 3) Bolt | 4) Base |
| 5) Nut | |

- Tyco grounding hardware comes in a package that includes the grounding bolt, mounting and grounding hex
- Electrical contact is made by penetrating the anodized coating of the aluminum frame, and tightening the mounting hex nut (come with the star washer) to the proper torque of 25lbf.in.
- Grounding wire size (6 to 12 AWG solid bare copper) should be selected and installed underneath the wire binding bolt.
- The wire binding bolt should be tightened to the proper torque of 45lbf.in.
- The Tyco grounding bolt is only listed for use with 6 to 12 AWG bare solid copper wire.

Method 3: ERICO grounding bolt # EL6CS14-6

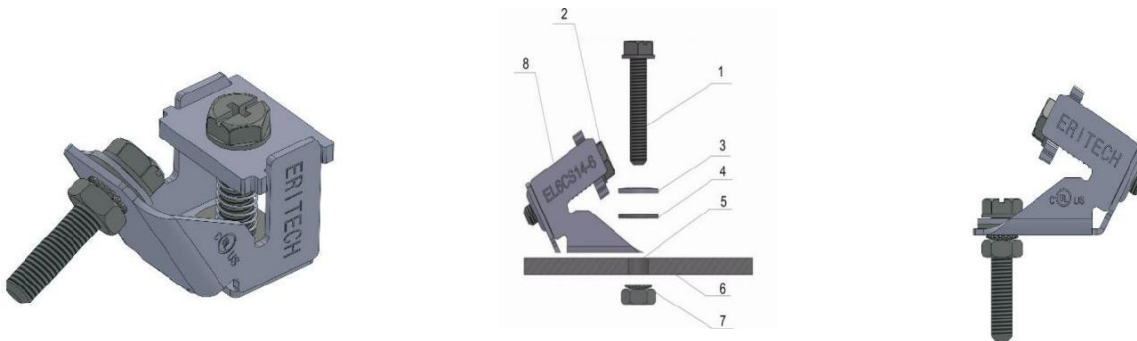

Figure 6. ERICO grounding bolt # EL6CS14-6
(Not applicable for the MaysunMOUNT module series)

- | | |
|--|-------------------|
| 1) Machine Bolt A 3) | 2) Machine Bolt B |
| Belleville washer | 4) Flat Washer |
| 5) Clearance hole for #10[M5] machine bolt | 6) Aluminum frame |
| 7) Machine box hex nut with lock washer | 8) Grounding bolt |



The lug should be installed on a surface that is larger than the bottom surface of the lug.
 The lug should be installed in the grounding holes provided on the PV module.
 Machine bolt A should be torqued to 35lbf.in, to secure the grounding bolt to module frame.
 The grounding bolt is only listed for use with 6-12 AWG bare solid copper wire.
 For proper wire binding, machine bolt B should be torqued to 35lbf.in.

6.3 MODULE WIRING

All wiring should be performed, by qualified installers, in accordance with the local codes and regulations.
 Modules can be connected in series to increase the operating voltage by plugging the positive plug of one module into the negative socket of the next. Before connecting modules always ensure that the contacts are corrosion free, clean and dry.

Product can be irreparably damaged if an array string is connected in reverse polarity to another. Always verify the voltage and polarity of each individual string before making a parallel connection. If you measure a reversed polarity or a difference of more than 10V between strings then check the string configuration before making the connection.

Maysun Solar modules are provided with stranded copper cables with a cross sectional area of 4mm²(0.006in²) which are rated for 1000V DC, 90°C and are UV resistant.(For MS.**, 1500 V DC, 90°C and are UV resistant)
 All other cables used to connect the DC system should have a similar (or better) specification. Maysun Solar recommend that all cables are run in appropriate conduits and sited away from areas prone to water collection.

The maximum voltage of the system must be less than the maximum certified voltage 1000V typically (For TSM-PE05A.** , PE14A.** , less than 1500V) and the maximum input voltage of the inverter and of the other electrical devices installed in the system. To ensure that this is the case, the open circuit voltage of the array string needs to be calculated at the lowest expected ambient temperature for the location. This can be done using the following formula.

$$\text{Max System voltage} \geq N * \text{Voc} * [1 + \text{TCvoc} * (T_{\text{min}} - 25)]$$

Where

- N No modules in series
- Voc Open circuit voltage of each module (refer to product label or data sheet)
- TCvoc Thermal coefficient of open circuit voltage for the module (refer to data sheet)
- Tmin The lowest ambient temperature

Each module have two standards 90°C sunlight resistant output cables each terminated with plug & play connectors. The wire type and gauge of the output cables are 1000V (For MS.** , ** which are 1500V DC) rated PV Wire cable and are 12AWG in size. This cable is suitable for applications where wiring is exposed to the direct sunlight. We require that all wiring and electrical connections comply with the appropriate National Electrical Code.

The minimum and maximum outer diameters of the cable are 5 to 7mm(0.038 to 0.076in²).

For field connections, use at least 4mm² copper wires insulated for a minimum of 90°C and sunlight resistance with insulation designated as PV Wire.

The minimum bending radius cables should be 43mm(1.69in).

MAYSUN SOLAR FZCO

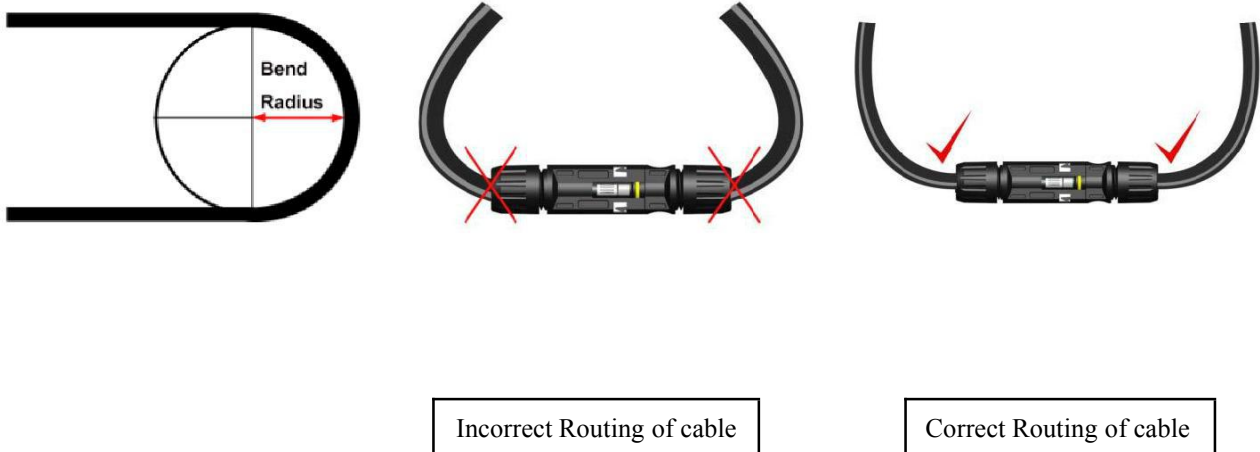

7. ELECTRICAL CONFIGURATION

Photovoltaic (electric) systems operate automatically and require very little day-to-day supervision. The solar array generates DC electricity whenever light falls on it similarly the inverter automatically turns ON as soon as there is sufficient energy from the solar array to efficiently convert this into grid.

***Caution:**

The module is rated to operate at potentially lethal DC voltages which have the potential can cause severe electrical shock, arcing and fire hazards. Whilst some solar modules, manufactured by Maysun Solar, are certified to operate up to 1000V DC (For MS.**, to 1500V DC) always check the module label to confirm the actual rating of your product before making connections.

It is recommended to use a suitably rated isolator (DC switch) to interrupt the current flow before disconnecting the connectors.

7.1 FUSING

When fuses are fitted they should be rated for the maximum DC voltage and connected in each, non-grounded pole of the array (i.e. if the system is not grounded then fuses should be connected in both the positive and negative poles).

The maximum rating of a fuse connected in series with an array string is typically 15A but the actual module specific rating can be found on the product label and in the product datasheet.

This fuse rating value also corresponds to the maximum reverse current that a module can withstand (when one string is shaded then the other parallel strings of modules will be loaded by the shaded string and current will flow) and therefore impacts the number of strings in parallel.

7.2 INVERTER SELECTION AND COMPATIBILITY

When installed in systems governed by IEC regulations, Maysun Solar modules normally do not need to be electronically connected to earth and therefore can be operated together with either galvanically isolated (with transformer) and transformerless inverters.

Potential Induced Degradation (PID) is sometimes observed in PV modules due to a combination of high humidity, high temperature and high voltage. PID is most likely to cause degradation under the following conditions:

- a) Installations in the warm and humid climates
- b) Installation close to a source of continual moisture, such as bodies of water

To reduce the risk of PID, we strongly suggest that modules feature Maysun Solar's Anti-PID technology, which can be applied to any Maysun product. Alternatively, we recommend the use of an inverter that includes a

MAYSUN SOLAR FZCO



transformer as well as proper grounding of the negative DC leg of the PV array.

Choose inverters with isolation transformers in hot and wet areas (such as shores, wetlands), to ensure proper module function under positive voltage.

8. MAINTENANCE AND CARE

A well designed solar system requires minimal maintenance; however, system performance and reliability can be improved by taking some simple steps.

Maintenance should be carried out at least once a year by trained personnel, always wearing rubber gloves and boots with maximum working voltage not lower than 1000V DC (For MS.***, not lower than 1500V DC).

Maysun any vegetation which may shade the solar array thus impacting performance. Check that mounting hardware is properly tightened.

Inspect all cables to verify that connections are tight; the cables are protected from direct sunlight and sited away from areas of water collection.

Check that all string fuses in each non/earthed pole are operating.

It is recommended to check the torque of terminal bolts and the general condition of wiring at least once a year. Also, check that mounting hardware is properly torqued. Loose connections will result in damage to the array.

Replacement modules must be of same type. Do not touch live parts of cables and connectors. Use appropriate safety equipment (insulated tools, insulating gloves, etc.) when handling modules.

The amount of electricity generated by a solar module is proportional to the amount of light falling on it. A module with shaded cells will produce less energy and therefore it is important to keep modules clean.

Normally rain water is sufficient to keep the modules clean however it is particularly important to ensure that the solar modules are clean before onset of summer. Products installed at a tilt angle below 10° or which are located in particularly dusty areas, are installed in landscape orientation or in areas of high pollution or close to large bird populations will require more regular cleaning.

When cleaning the module use a soft cloth together with a mild detergent and clean water. Take care to avoid severe thermal shocks which might damage the module by cleaning modules with water which has a similar temperature to the modules being cleaned.

When cleaning the back surface of the module, take care to avoid penetrating the substrate material. Modules that are mounted flat (0° tilt angle) should be cleaned more often, as they will not "self-clean" as effectively as modules mounted at a 10° tilt or greater.

The benefit of cleaning dirt and debris from the array is a trade-off between the cost of the cleaning, increased energy production as a result of this cleaning, and the inevitable re-soiling of the laminates over time once they have been cleaned.

In the event that the solar modules need to be cleaned then clean the module use a soft cloth together with a mild detergent and clean water. Take care to avoid severe thermal shocks which might damage the module by cleaning modules with water which has a similar temperature to the modules being cleaned.

On large systems, the benefit of cleaning dirt and debris from the array is a trade-off between the cost of the cleaning, increased energy production as a result of this cleaning, and the time for the re-soiling of the modules after cleaning.

If you are unsure whether the array or section thereof needs to be cleaned then first select an array string that is particularly soiled then

- Measure & record the inverter feed in current from that string
- Clean all modules in the string
- Measure the inverter feed in current again and calculate the % improvement from cleaning
- If the improvement is less than 5% then it is normally not worth spending the expense on cleaning

The above verification should only be carried out when the insolation is effectively constant (clear sky, strong sunshine, no clouds)

The back surface of the module normally does not need to be cleaned but, in the event this is deemed necessary, avoid the use of any sharp projects that might damage the penetrating the substrate material.

Cover the front surface of modules by an opaque material when repairing. Modules when exposed to sunlight generate high voltage and are dangerous.

Maysun Solar PV modules are equipped with bypass diodes in the junction box. This minimizes module heating and current losses.

- Do not try to open the junction box to change the diodes even if they malfunction.
- In a system using a battery, blocking diodes are typically placed between the battery and the PV module output to prevent battery discharge at night.



Product Replacement:

In the event that a module is damaged (broken glass or scratch on back sheet) and needs to be replaced then

- Observe the safety precautions listed earlier in the manual
- Wear cut resistant gloves and other personal protective equipment required for the particular installation.
- Isolate the impacted array string to prevent current flow before attempting to remove the module.
- Disconnect the connectors of the affected module using the related disconnect tool provided by suppliers.
- Replace the damaged module with a new module of the same type.
- Check the open circuit voltage of the array string and verify that this is within 10V of the other strings to be connected in parallel.
- Turn the isolator back on.

Troubleshooting:

- If your installation does not work properly, please inform your installer immediately.

Reporting Technical Issues or Claims:

- Contact your installer
- Contact Maysun Solar after sales service team at <http://www.maysunsolar.com>
- For module specifications or datasheets, please download from: <http://www.maysunsolar.com>

9. WARNING

WARNING: For any electrical maintenance, the PV system must first be shut down. Improper maintenance can cause lethal electric shock and/or burns.