GSM Series Outdoor Central Inverter



PART 01

KSTAR Company Profile

Powering Green Future

Company Profile

Founded in 1993, Shenzhen KSTAR Science & Technology Co., Ltd is a pioneer of UPS industry and a total solution provider for Data Center Critical Infrastructure & PV Inverter Systems in Mainland China.

KSTAR has been providing high-quality products to over 90 countries and regions worldwide, leading the industrial development with innovation.

With a floor area of 150,000 square meters and a building area of 167,000 square meters, KSTAR R&D and manufacturing base is a world-leading base in terms of scale and manufacturing equipment.

KSTAR Development history of the company



1993 Company Established

- 1993 Offline UPS
- 1995 Low-power Online UPS
- 1996 Entering the European & US markets

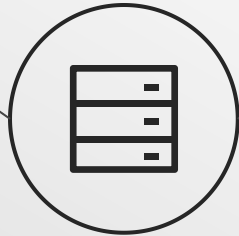

2000 Guanlan Industrial Park, Shenzhen

- Medium-power Online UPS
- 2001 Storage Battery
- 2004 High-power Online UPS
- 2005 IDC Integrated System
- 2008 Certified as National Hi-Tech Enterprise & DC Power

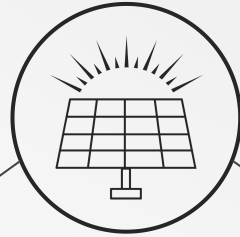

2009 Zhongkai Industrial Park, Huizhou

- 2009 PV Inverter
- 2009 Establish 1st PV Inverter



2010 Listed in Shenzhen Stock Exchange

- 2013 Opened Guangming Industrial Park, Shenzhen
- 2013 EV Charger
- 2014 ESS Products

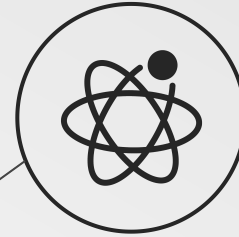

2019 Established CATL KSTAR JV

- 2015 National Enterprise Technical Center
- 2018 JiangXi ChangXin factory for energy storage product

Development Milestone Office and service center globally



- 18 Overseas Branch
- 40 Overseas Service Engineers
- Global Service Network
- 24/7 Response and Support

KSTAR Development history of the company



1993 Company Established

- 1993 Offline UPS
- 1995 Low-power Online UPS
- 1996 Entering the European & US markets

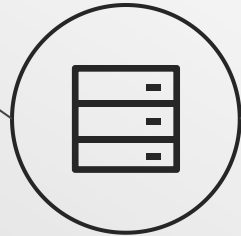

2000 Guanlan Industrial Park, Shenzhen

- Medium-power Online UPS
- 2001 Storage Battery
- 2004 High-power Online UPS
- 2005 IDC Integrated System
- 2008 Certified as National Hi-Tech Enterprise & DC Power

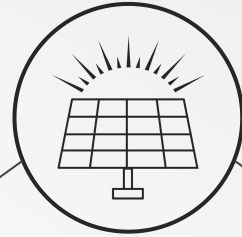

2009 Zhongkai Industrial Park, Huizhou

- 2009 PV Inverter
- 2009 Establish 1st PV Inverter



2010 Listed in Shenzhen Stock Exchange

- 2013 Opened Guangming Industrial Park, Shenzhen
- 2013 EV Charger
- 2014 ESS Products

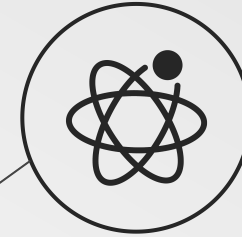

2019 Established CATL KSTAR JV

- 2015 National Enterprise Technical Center
- 2018 JiangXi ChangXin factory for energy storage product

PART 02
Outdoor Central Inverter Solution
Powering Green Future

Utility Medium-voltage PV Solution

1500Vdc 600Vac GSM series outdoor inverter, best choice for Utility-scale PV system

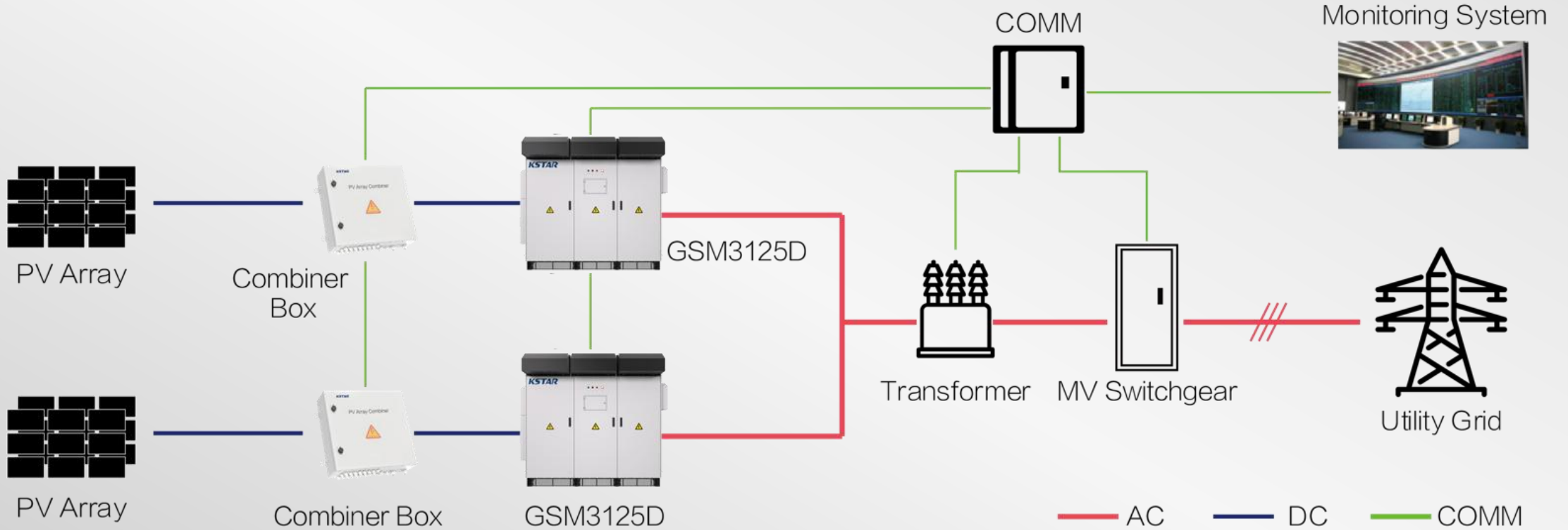

Block Diagram of Utility Medium-voltage System

GSM Series Central Inverter

GSM2500D/GSM3125D, Max. 1.1 time nominal AC output

Low LCOE

Outdoor installation
Max. 6.25MW block design
1500Vdc with 2 MPPT
Wide Vmpp range 875~1300V
Max. efficiency up to 99%
Support bifacial module
Max. DC/AC ratio up to 1.8



Grid Support

Active & Reactive power control
Fast power response
Night SVG function optional
LVRT/HVRT
BESS interface reserved



Safe & Reliable

IP55 protection degree
C5 Anti-corrosion
Efficient heat dissipation
Anti-PID function
DC & AC type II SPD
Stable operation@-40°C
DC reverse polarity protection
Leakage current fault protection
Insulation detection

Low LCOE – Outdoor Installation



1st Generation

Cement House for Indoor Inverter

- Large area
- Construction progress easily affected by weather
- Installation of ventilation and lighting system on site
- High cost



2nd Generation

10ft Shipping Container for Indoor Inverter

- Foundation for container of W2991*D2438mm
- High quality foundation required
- High cost of container and foundation



3rd Generation

IP55 Outdoor Inverter

- Foundation for inverter of W2350*D1300mm
- Small & simple foundation for saving area
- Easy & Quick outdoor installation
- Low cost

Low LCOE – Max. 6.25MW Block Design

The block capacity larger, the LCOE lower

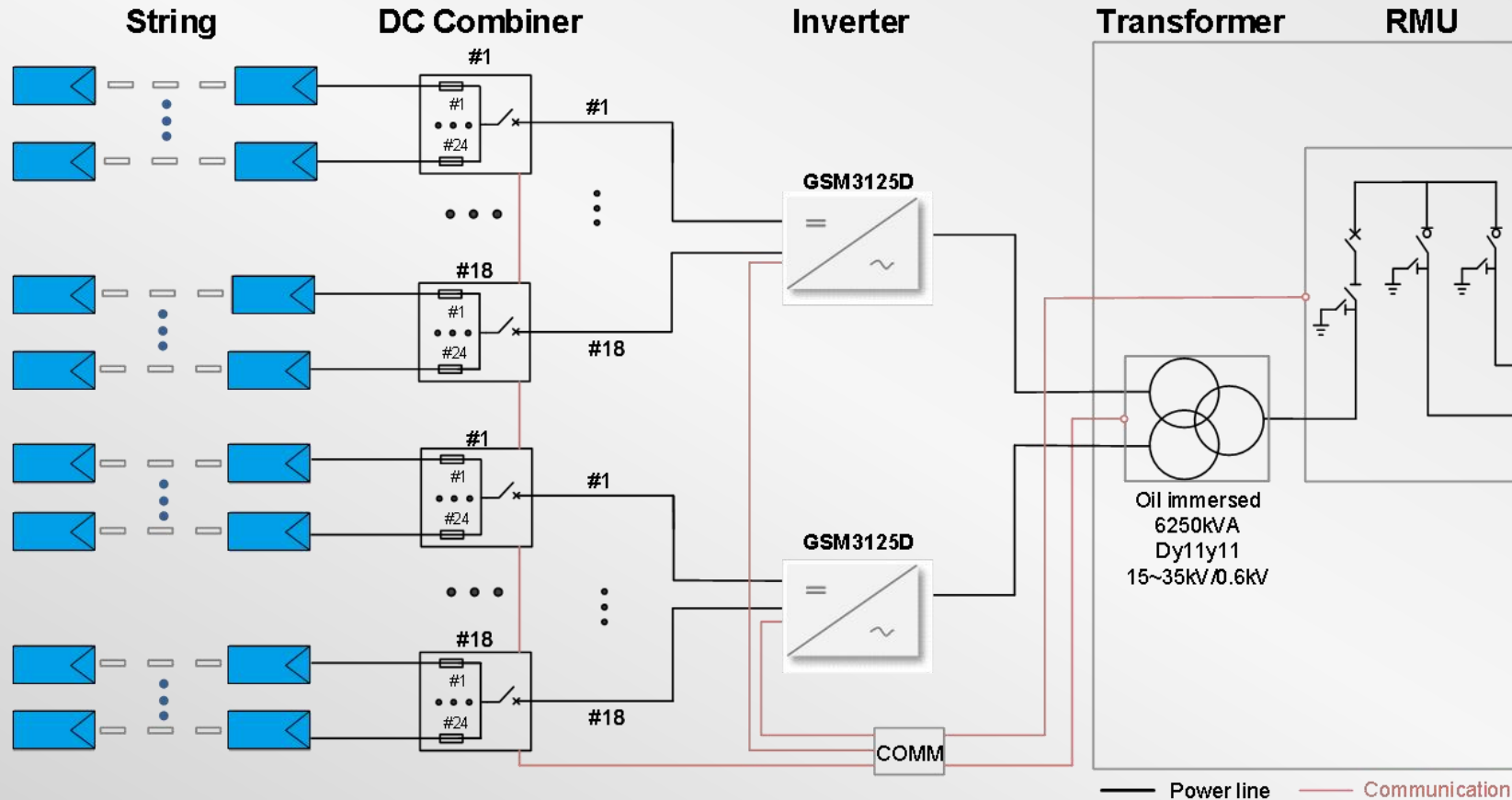

Single Line Diagram of 6.25MW Block

Low LCOE – 1500Vdc with 2 MPPT

Compared with DC1000V system, DC1500V system has lower system cost

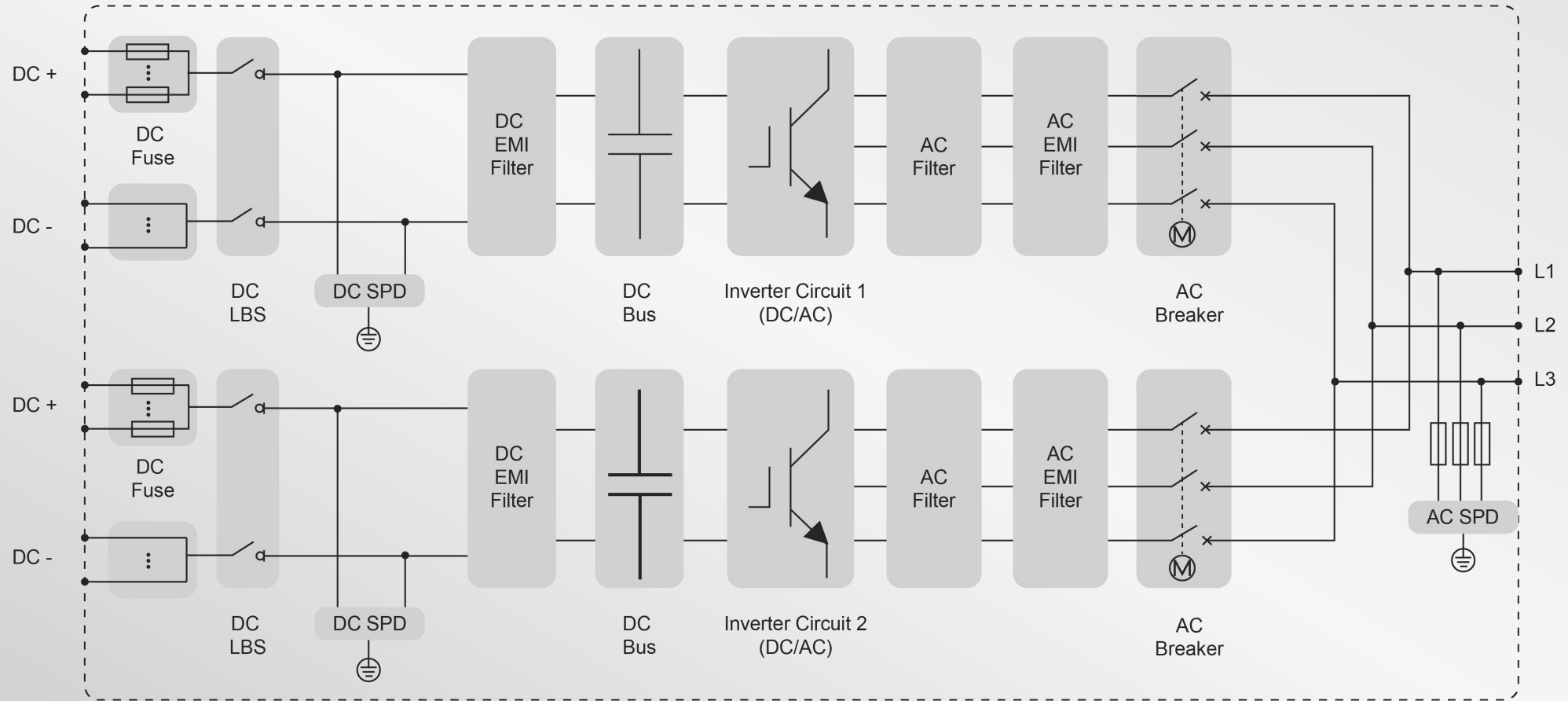

Circuit Diagram of GSM Central Inverter

Low LCOE – 1500Vdc with 2 MPPT

Compared with 1 MPPT, Shading effect and mismatch can be effectively reduced with 2 MPPT

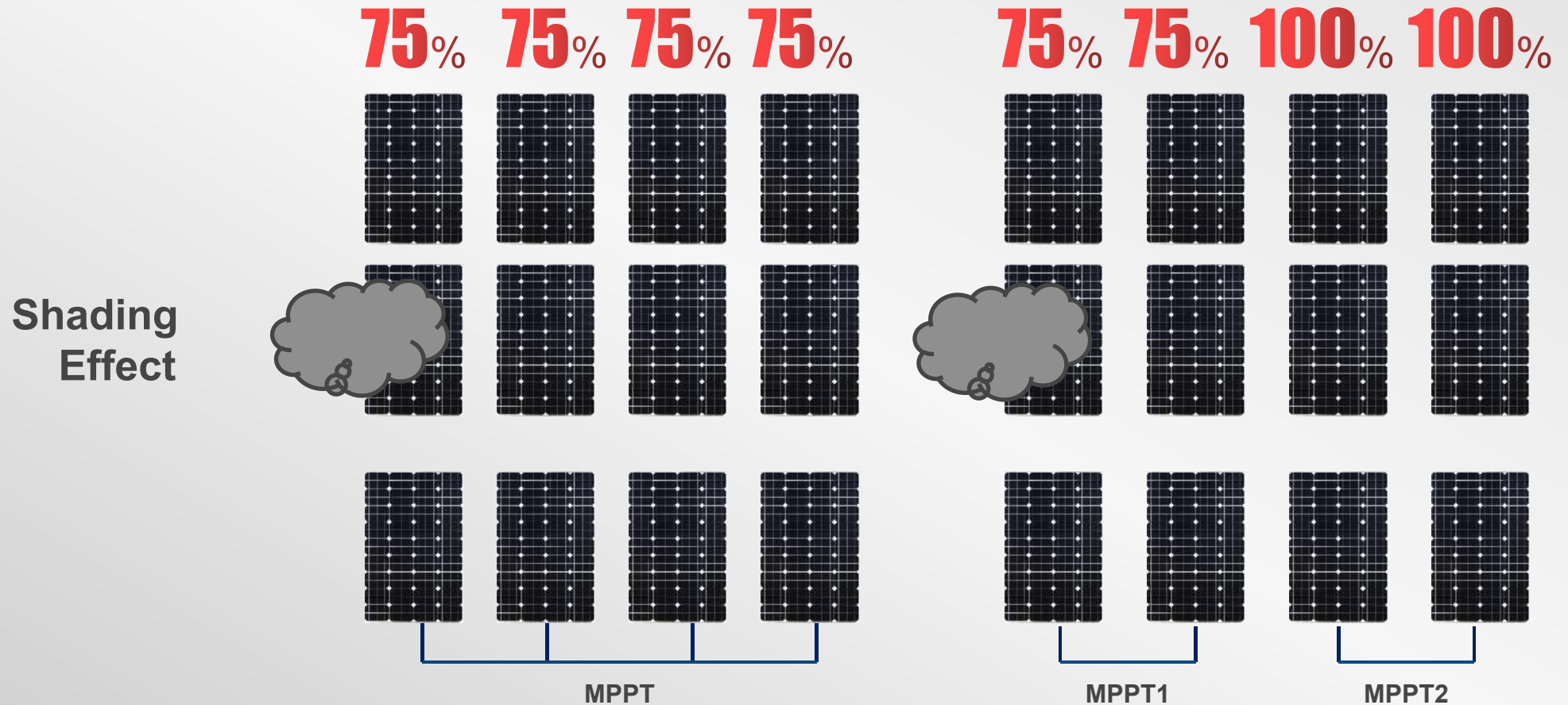

Higher Efficiency – Max. Efficiency up to 99%

Lower loss brings higher efficiency, reduce LCOE, increase power generation and benefit

GSM2500D Efficiency Curve according to IEC61683 Test Report

	5%	10%	20%	30%	50%	75%	100%
875Vdc	97.517%	98.355%	98.737%	99.023%	98.911%	98.817%	98.629%
1085Vdc	97.269%	98.170%	98.575%	98.833%	98.739%	98.595%	98.425%
1300Vdc	97.022%	97.953%	98.388%	98.559%	98.526%	98.388%	98.243%

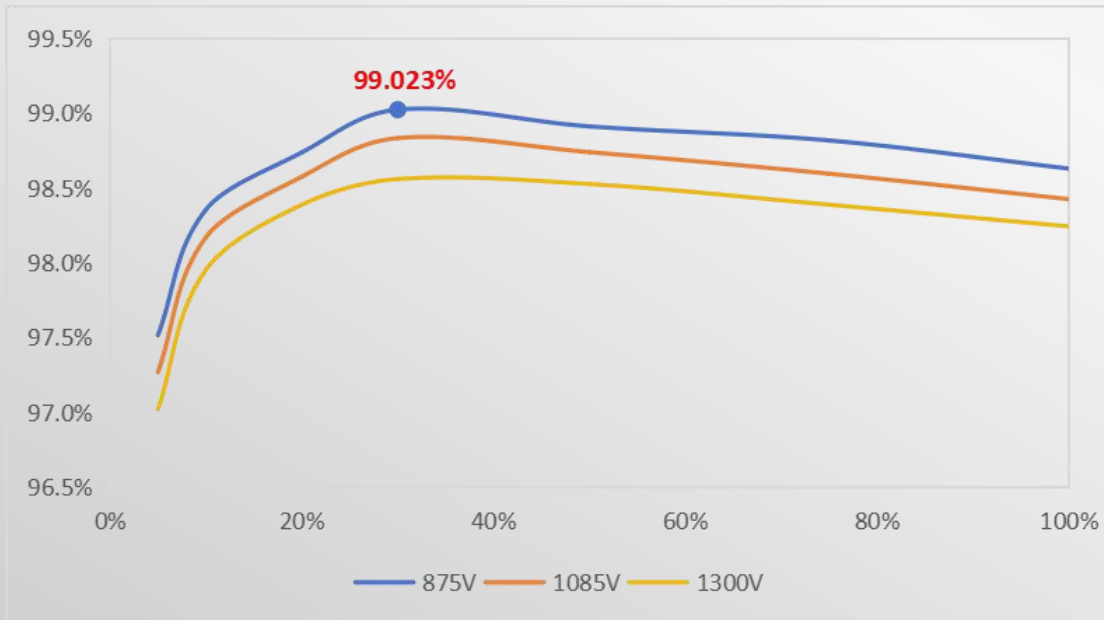

GSM3125D Efficiency Curve according to IEC61683 Test Report

	5%	10%	20%	30%	50%	75%	100%
875Vdc	97.487%	98.350%	98.739%	99.014%	98.918%	98.800%	98.267%
1085Vdc	97.245%	98.164%	98.561%	98.816%	98.747%	98.609%	98.425%
1300Vdc	97.025%	98.026%	98.394%	98.541%	98.517%	98.409%	98.252%

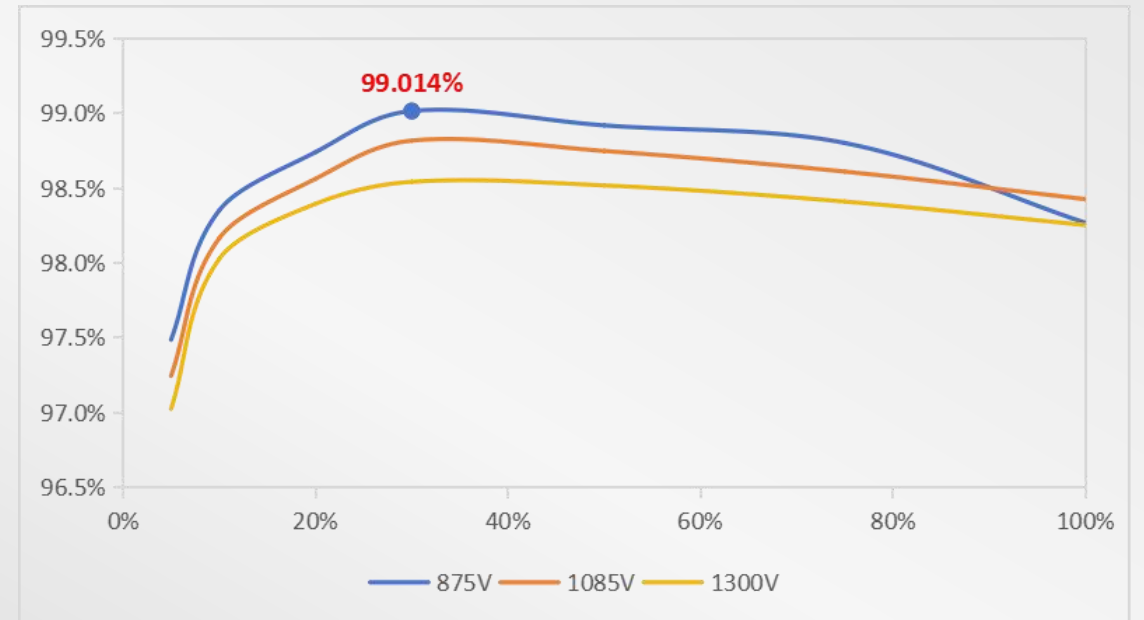

Low LCOE – Support Bifacial Modules

400A ~ 550A DC input fuse optional, Support PV modules with high current such as 600Wp+ Bifacial PV modules

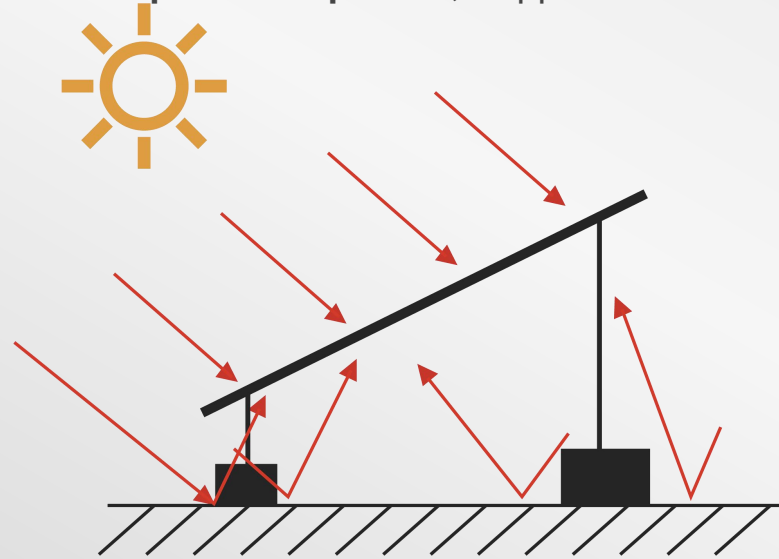

600 Wp Module	Single Face	5% Gain	10% Gain	15% Gain	20% Gain	25% Gain
Peak Current	17.34A	18.21A	19.07A	19.94A	20.81A	21.68A

Imp with different rear side power gain

Typical 600Wp+ Bifacial modules with 25% backside power gain have 21~22A of Imp

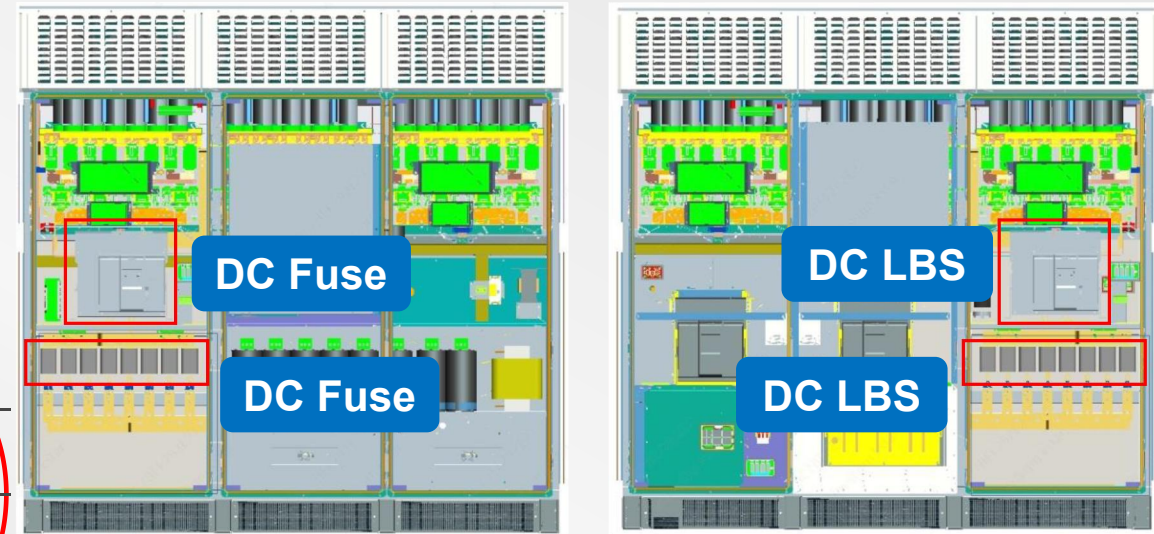

Front View

Back View

Layout of GSM Central Inverter

Standard configuration with 24*400A DC input fuses, 500A or 630A fuse optional

Low LCOE – Support High DC/AC Ratio

High DC/AC ratio can compensate for module degradation over years

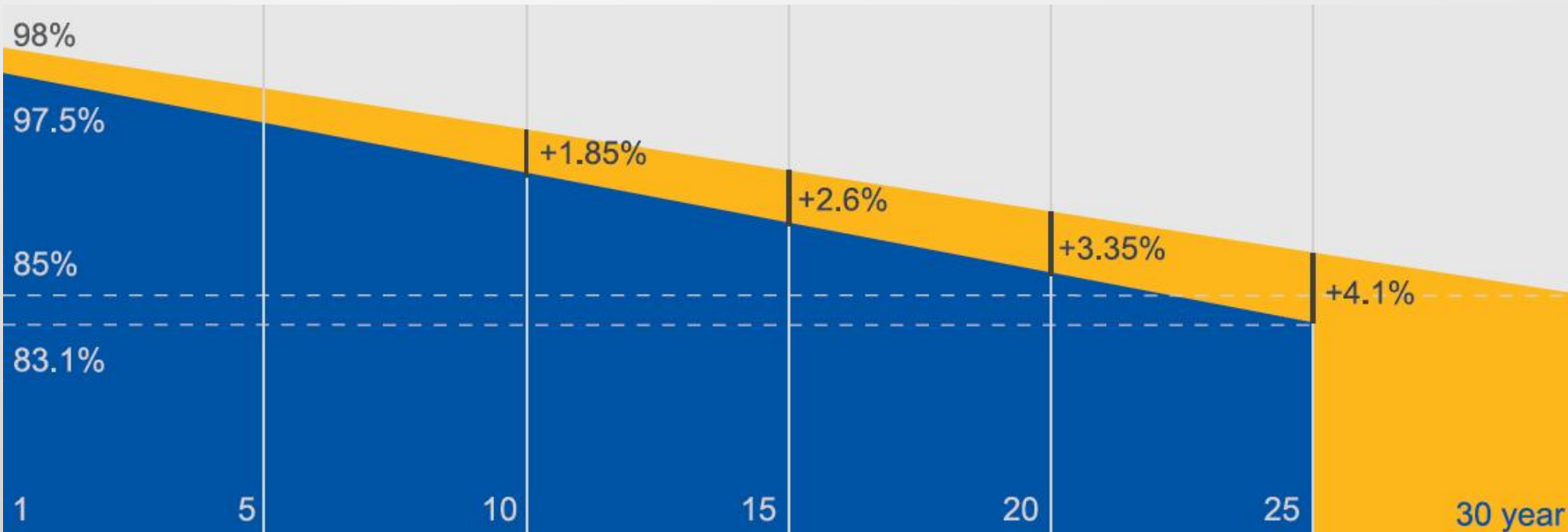

Degradation Curve of PV Module

Low LCOE - Max. DC/AC Ratio 1.8

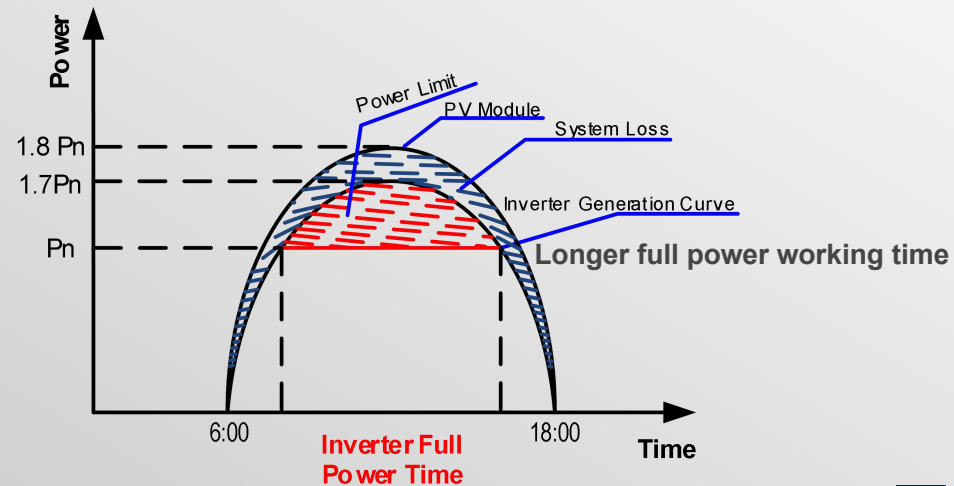
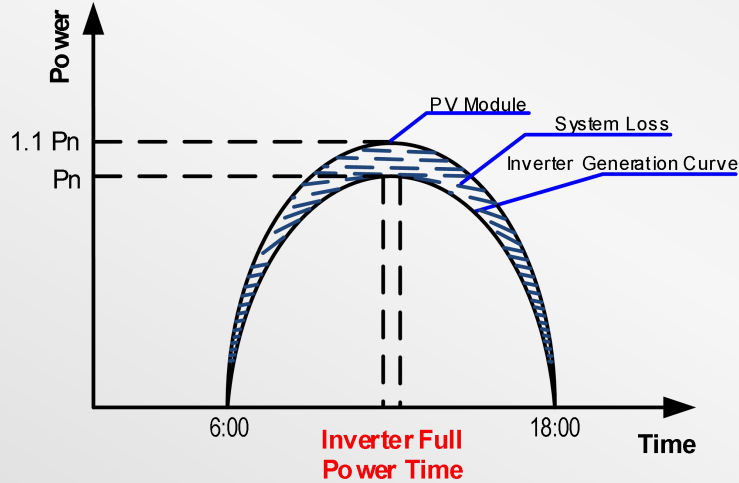

High DC/AC ratio up to 1.8

The high DC/AC ratio makes the inverter 100% power output for longer time duration which can get more production, and can be used for low LCOE plant design

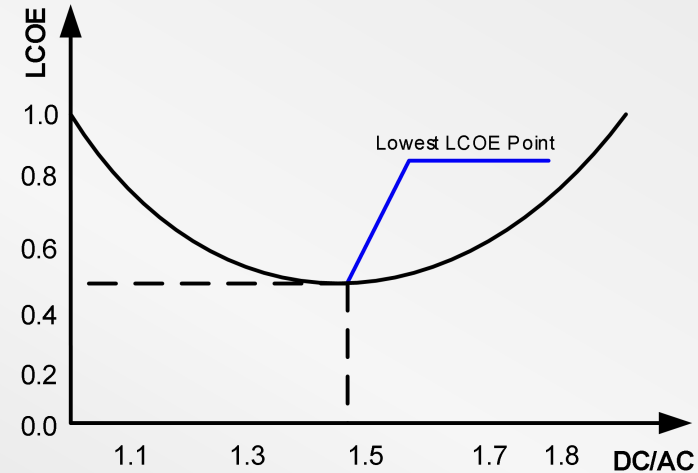

$$\text{LCOE} = \frac{\text{Total Life Cycle Cost}}{\text{Total Lifetime Energy Production}}$$

Grid Support – Active & Reactive Power Control

The max. reactive power output of the inverter can reach 66% of the rated apparent power, power factor ± 0.8 adjustable, and Night SVG function is optional, saving cost on Q compensation equipment

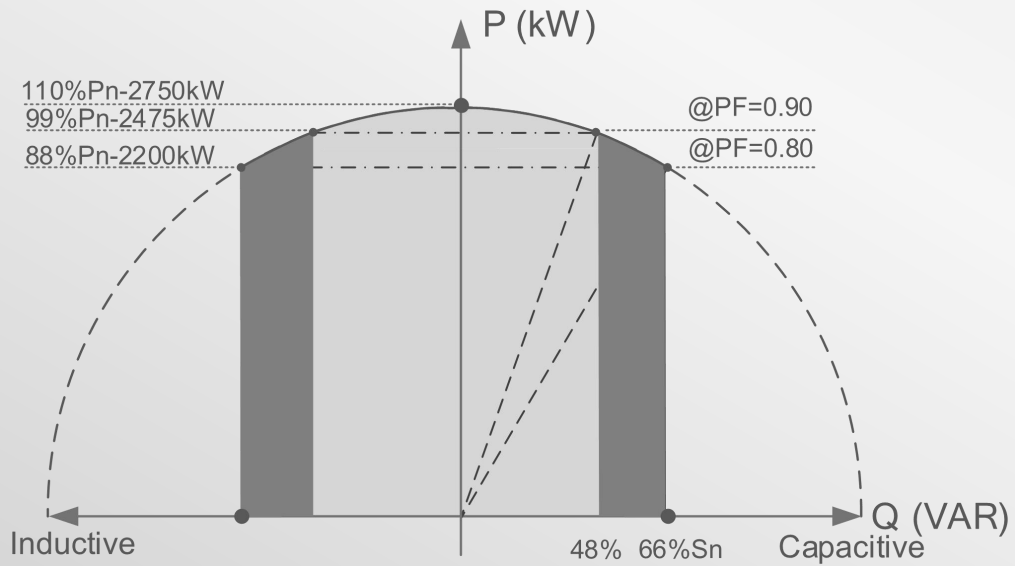

GSM2500D PQ Curve

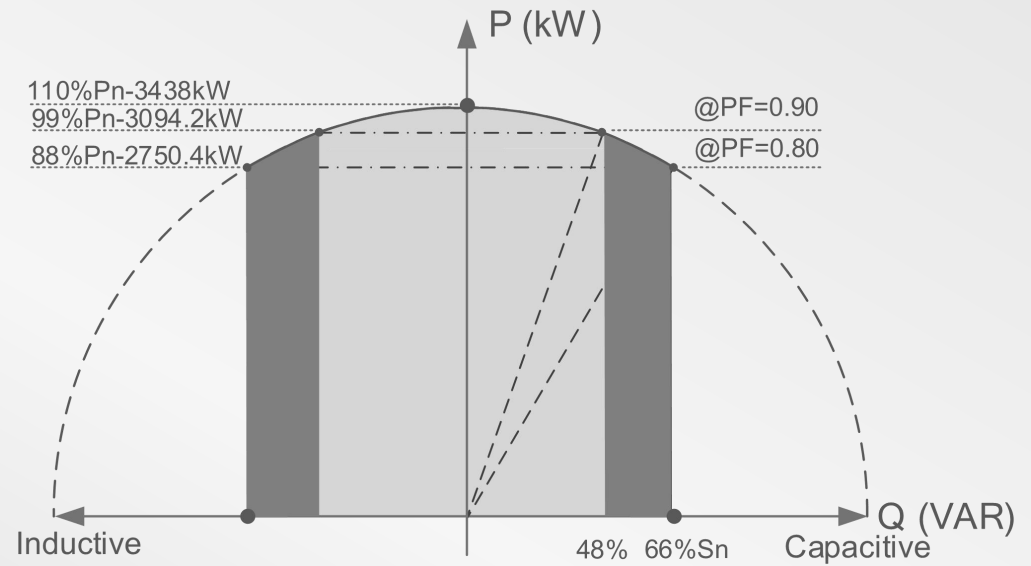

GSM3125D PQ Curve

Grid Support – Fast Power Response

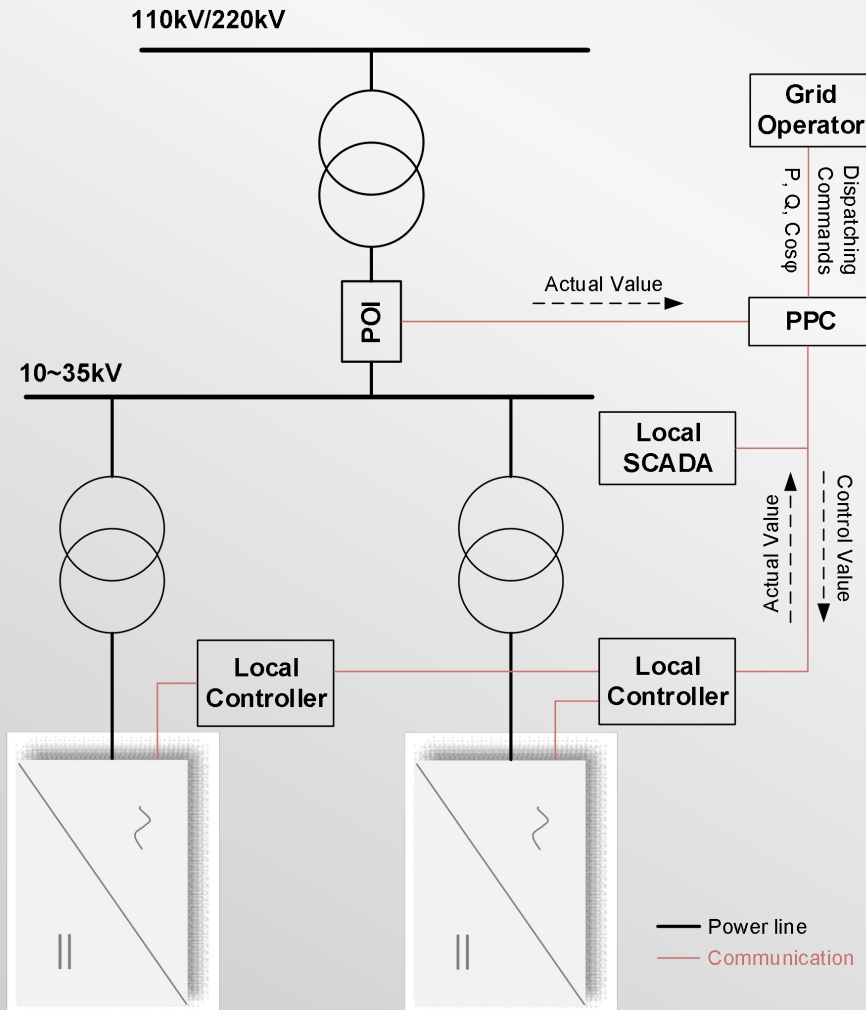

Power Response Time < 30ms

No.	Sections of Communication Loop	Time Delay (ms)
1	Grid Operator to PPC	1000
2	PPC to Local Controller	1000
3	Local Controller to Inverter	250
4	Response of Inverter	<30
5	Inverter to Local Controller	250
6	Local Controller to PPC	1000
7	PPC to Grid Operator	1000

Grid Support – LVRT/HVRT

Integrated with LVRT/HVRT function can stabilize and support the grid, voltage value and time duration at different point are adjustable according to different grid code

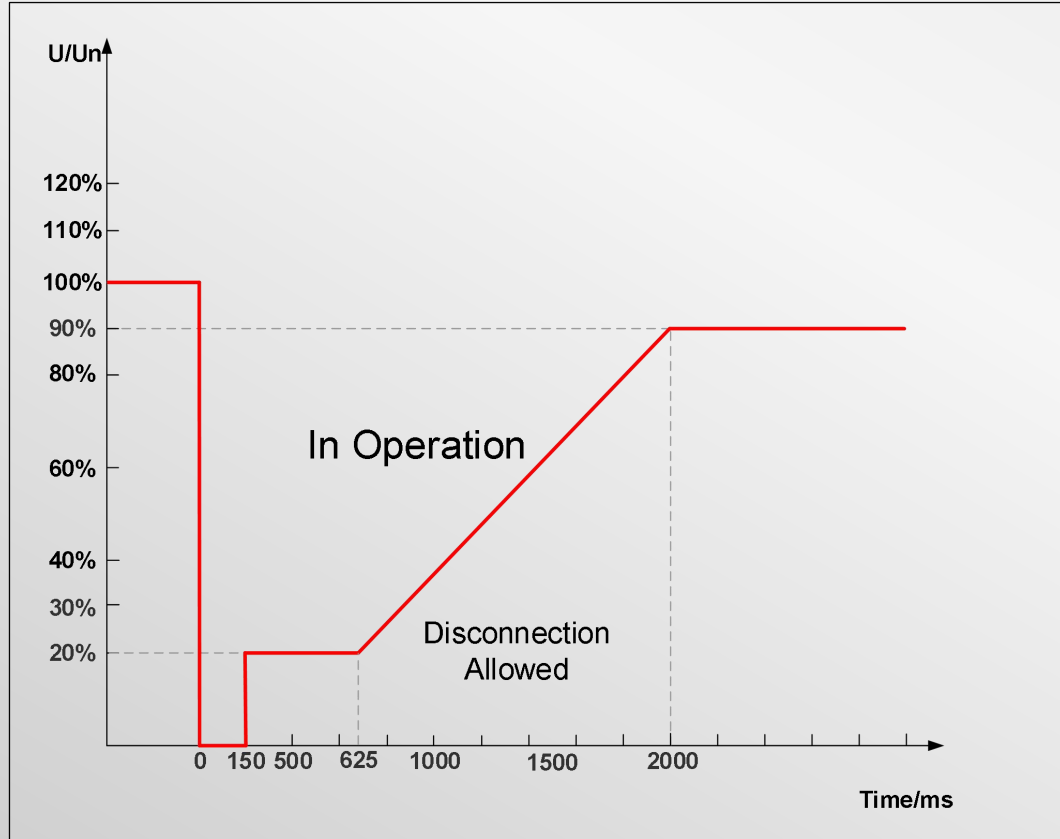

LVRT Curve based on GB Standard

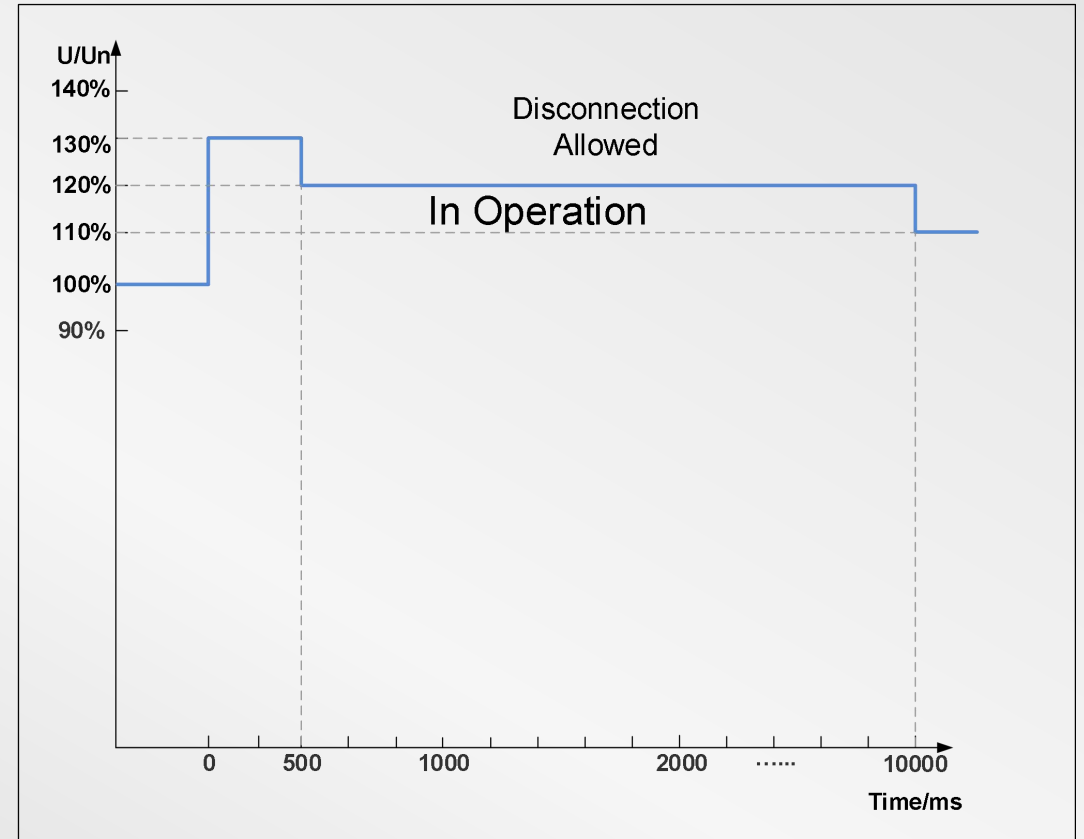

HVRT Curve based on GB Standard

Grid Support – BESS Interface Reserved

BESS on DC coupling system can smooth power output of PV plant and reduce abandonment of sunshine especially when DC/AC ratio is high

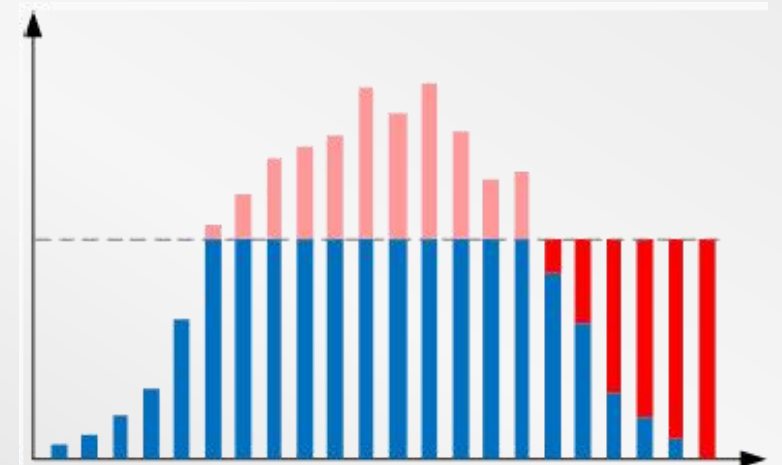
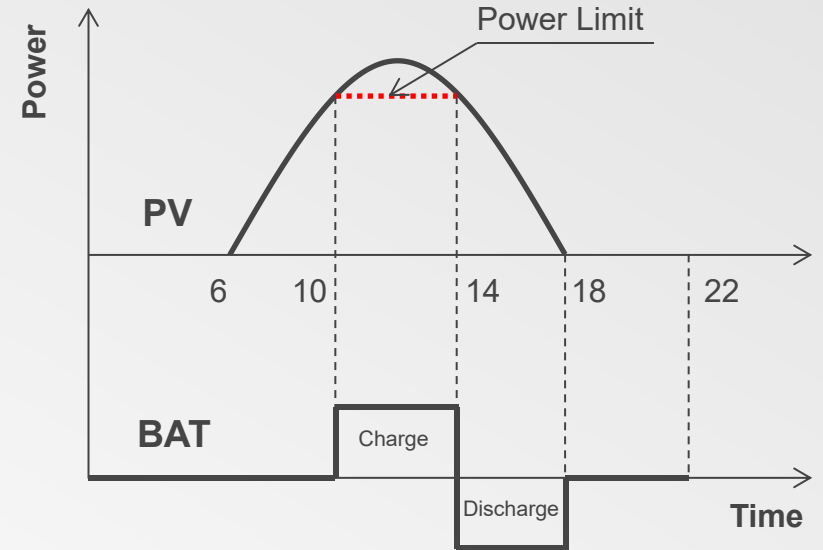
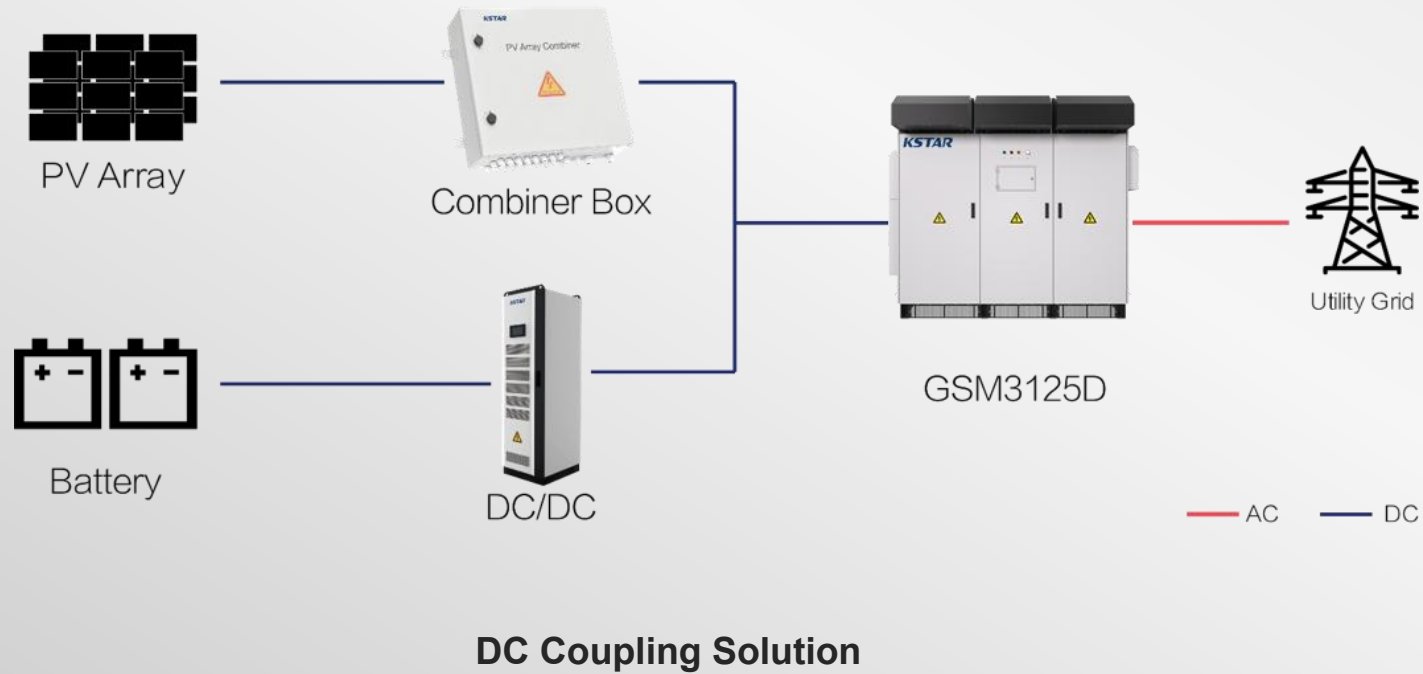

Safe & Reliable – IP55 Ingress Protection

IP55 ingress protection can ensure outdoor installation and suitable for sandy and rainy projects



Safe & Reliable – Smart Forced Air Cooling

Smart forced air cooling guarantees 25+ years stable working



Advanced heat exchange design makes it perfectly adapted to high temperature environments

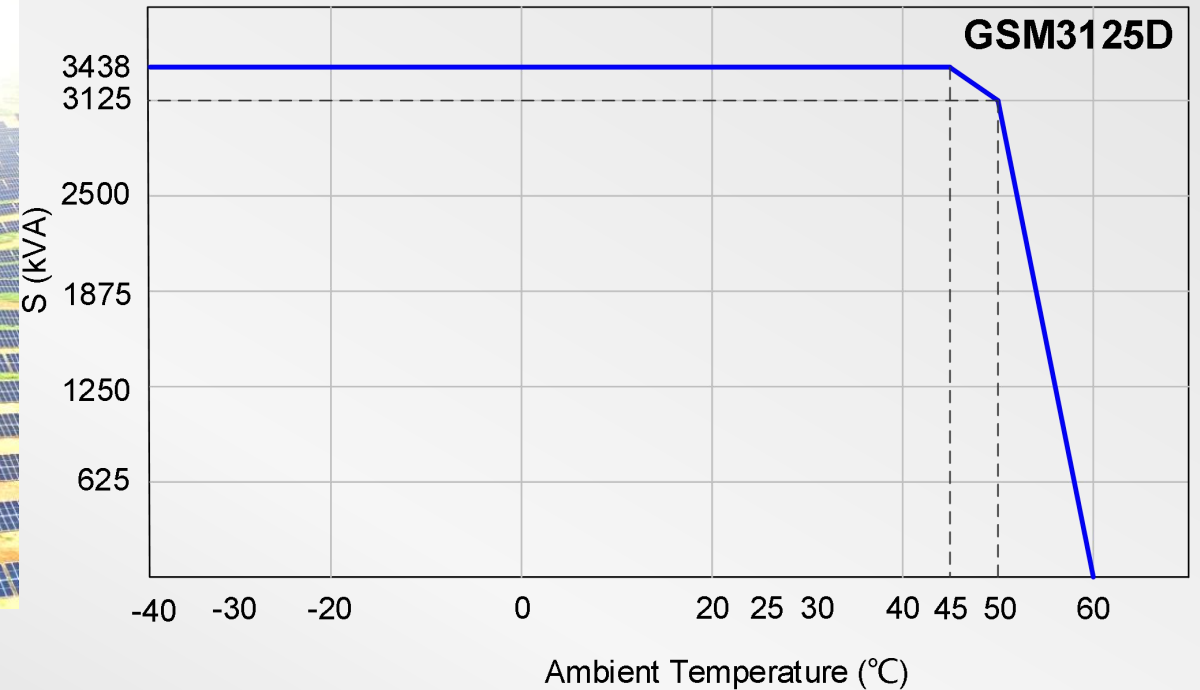

GSM3125D Temperature Curve

Safe & Reliable – C5 Anti-corrosion

C5 Anti-corrosion protection is suitable for coastal projects

Three-layer Coating Protection

1. Fluorocarbon topcoat

Against acid and alkali, sea water and air

2. Zinc-rich primer

Against chemical corrosion and water

3. Galvanizing zinc coating

Against corrosion and rust



Safe & Reliable – Anti-PID Function

The Anti-PID function can effectively protect the PV modules from Potential Induced Degradation

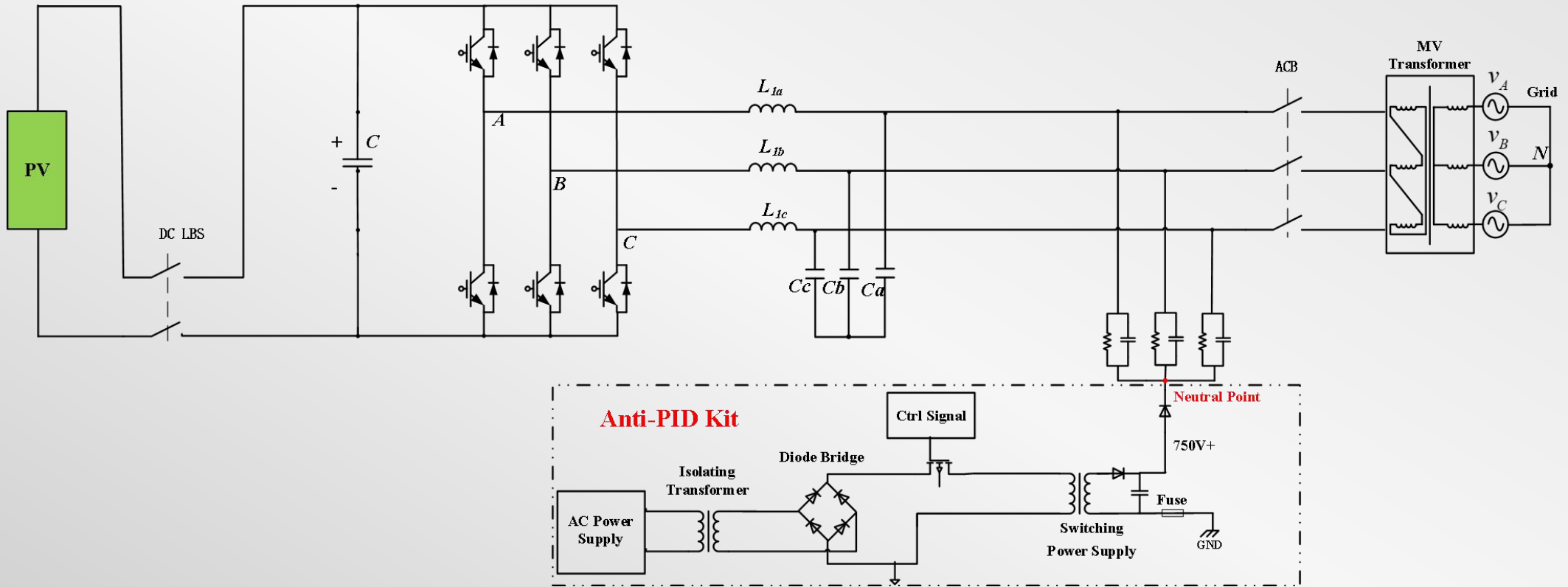

Block Diagram of Anti-PID Function

GSM3125D Technical Specifications



MODEL	GSM2500D	GSM3125D
Input(DC)		
Max. DC Voltage	1500V	1500V
Min. / Startup Voltage	860V / 940V(adjustable)	860V / 940V(adjustable)
MPPT Voltage Range	875~1300V	875~1300V
No. of MPPT	2	2
No. of DC Input	Max. 18	Max. 18
Max. DC Input Current	3207A	4009A
Output(AC)		
Nominal AC Output Power	2500kW@50°C	3125kW@50°C
Max. AC Output Power	2750kVA@45°C	3438kVA@45°C
Nominal AC Voltage	600V/3W+PE	600V/3W+PE
AC Voltage Range	510~660V	510~660V
Rated AC Output Current	2406A	3007A
Max. Output Current	2646A	3308A
Power Factor	0.8leading~0.8lagging	0.8leading~0.8lagging
Efficiency		
Max. Efficiency	99.0%	99.0%
Euro Efficiency	98.7%	98.7%

20/40ft Standard Container MV Turnkey Solution

All-in-one ITS

1/2*Central Inverter + LV/MV Transformer + RMU in 20/40ft Shipping Container

Front View:

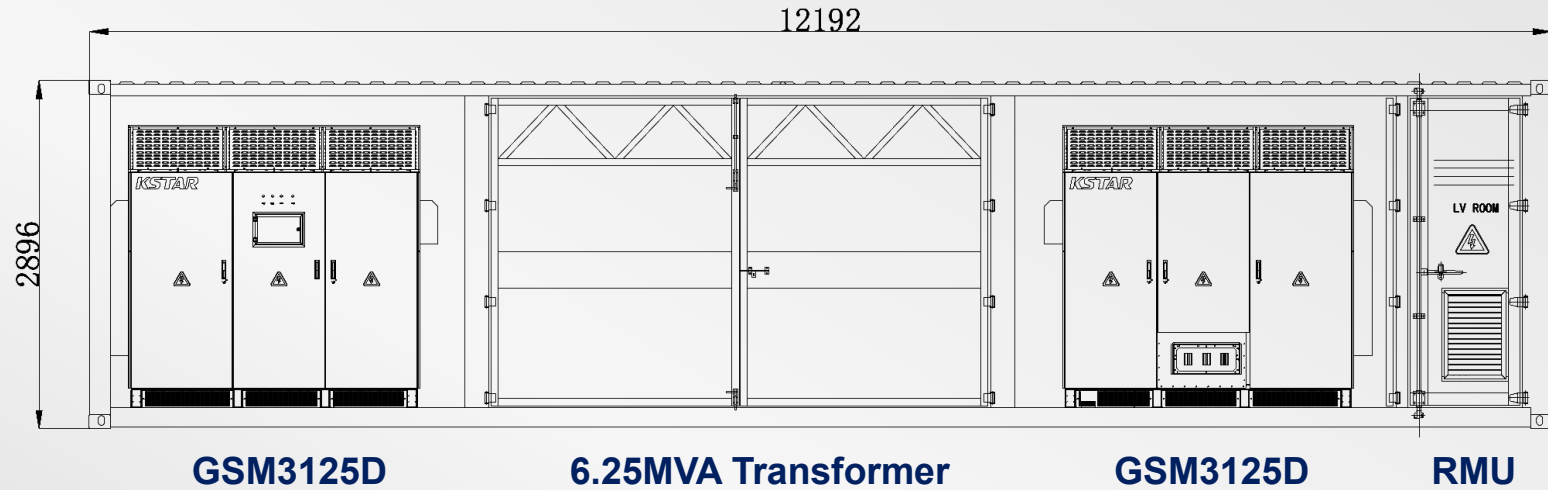

Top View(Perspective):

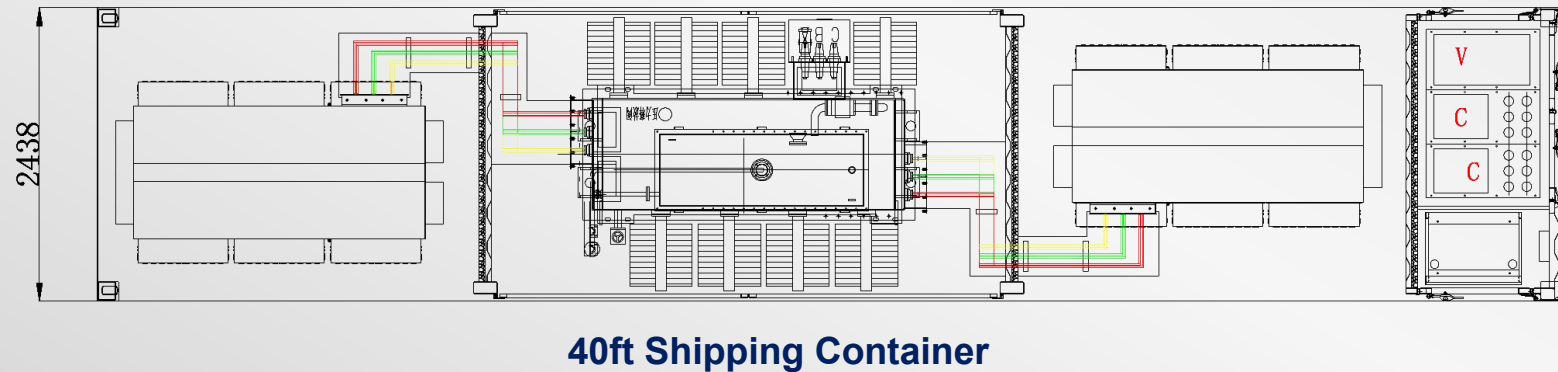

6.25MVA Oil-type Transformer Technical Specifications

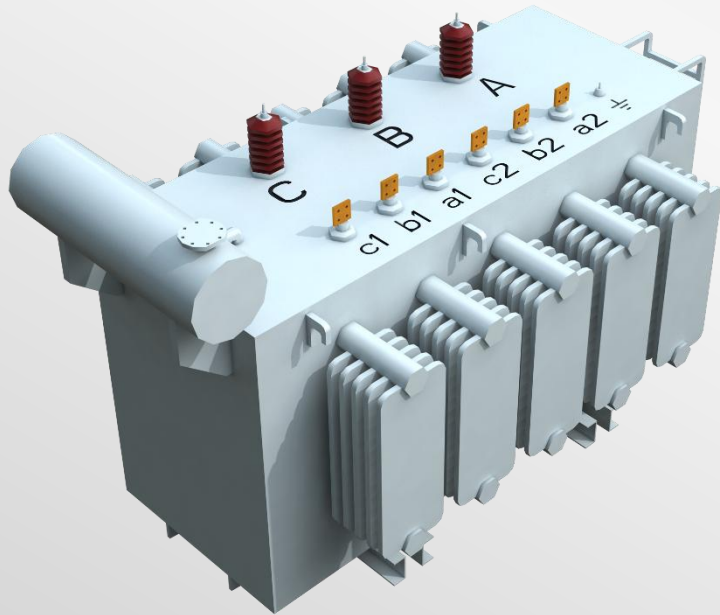

LV/MV Transformer

Rated Power	6250kVA@50°C
Rated Voltage	15~35kV/0.6kV-0.6kV
Tap Changer	Off-Circuit-Tap-Changing
Tap Range	$\pm 2 \times 2.5\%$
Vector Group	Dy11y11 or y11
Cooling Type	ONAN
Oil Type	Mineral Oil (PCB Free)
Winding Material	Aluminum
No Load Loss/Load Loss	Eco Design EU548(Optional)
Monitoring	Oil Pressure, Oil Level and Oil Temperature
Standard	IEC60076

SF6 MV Switchgear Technical Specifications

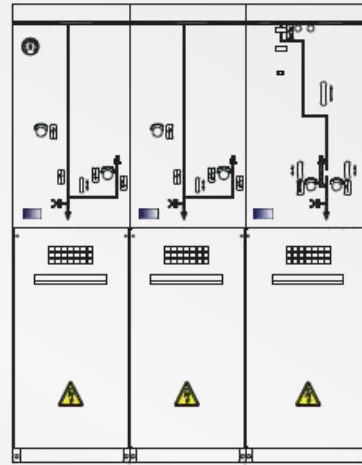

CCV

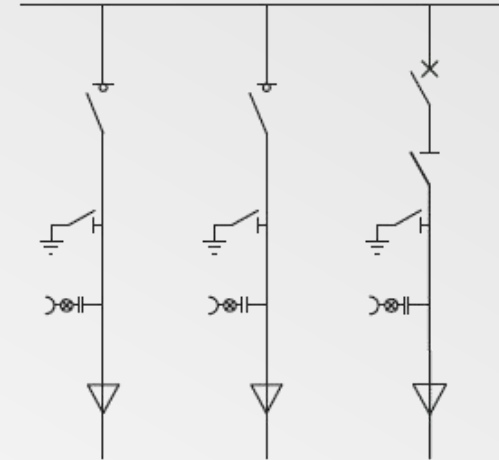

SF6 MV Switchgear (RMU)

Configuration

V: Vacuum circuit breaker unit for transformer protection
 C: Cable load break switch unit for ring network connection
 D: Direct cable unit (Optional)

Rated Voltage	24kV/36kV/40.5kV
Rated Current	630A
Rated Short-circuit Breaking Current	20/25kA
Rated Short-time Withstand Current	20/25kA
Remote Control	Motor Driven (Optional)
Standard	IEC62271

Monitoring System Communication Connection

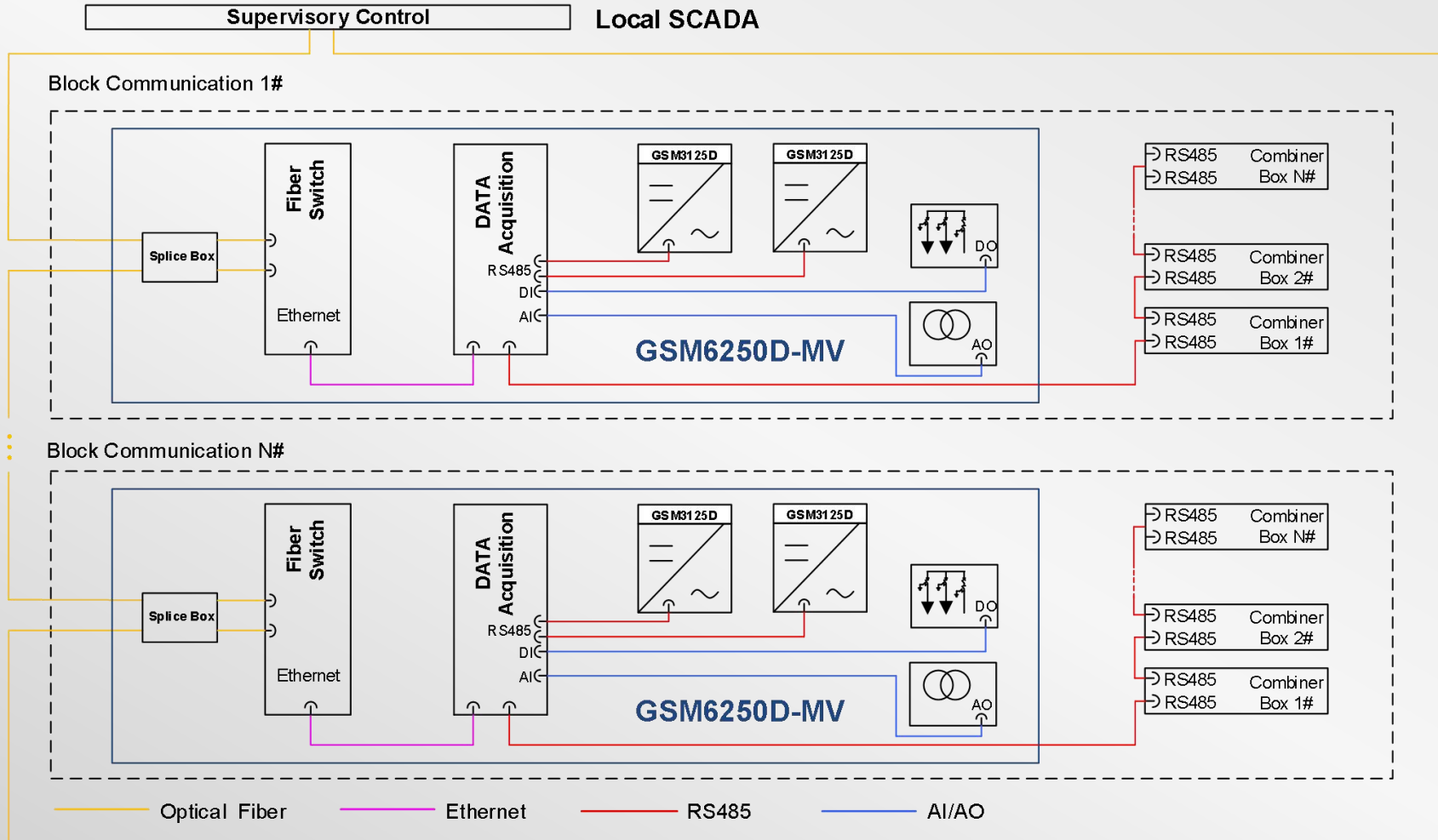

Monitoring System Diagram



PART 03

Reference

Powering Green Future

Jingneng Ningxia 150MW Project, China



1500V 3.125MW Outdoor Inverter Solution

CGN Qinghai 200MW Project, China



1500V 3.125MW Outdoor Inverter Solution

Shaanxi Baoji 200MW Project, China



1500V 3.125MW Outdoor Inverter Solution

Nikopol 200MW PV Plant, Ukraine



Low temperature, 1000V 2.5MW ITS, First 100MW+ Project in Ukraine

Pokrovskaya 240MW PV Plant, Ukraine



Low Temperature, 1500V 2.5MW ITS Solution, DC/AC ratio 1.38

Astrakhan I / II / III 400MW PV Plant ,Russia



Low Temperature, 40ft / 20ft ITS Solution

Samara I / II 300MW PV Plant ,Russia



Low Temperature, 40ft / 20ft ITS Solution

Bahawalpur 100MW PV Plant, Pakistan



The Belt and Road Initiative, High Temperature

SPIC Heilongjiang 500MW Project, China



Low Temperature, 1500V 3.125MW ITS Solution

Zhejiang CiXi 300MW Water Surface PV Plant, China



The Largest Water Surface PV Plant in the World

Sevilla 10MW PV Plant, Spain



1500V 5MW ITS Solution

KSTAR Powering
Green
Future