



Test Report

No.: SHHL241006191201FT

Date: OCT. 28, 2024

Page: 1 of 6

Sample Description : BUNK BED
 SGS Ref No. : TJHL2410009158FT
 Style No. : AS110
 Item No. : AS110

Source of Sample : SENT BY CLIENT.
 Sample Receiving Date : OCT. 21, 2024
 Testing Period : OCT. 21, 2024 TO OCT. 28, 2024
 Testing Location : LANE 3999, XIUPU RD., PUDONG DISTRICT, SHANGHAI, CHINA

Test Requested	Result
DIN EN 747-1: 2024 - FURNITURE — BUNK BEDS AND HIGH BEDS PART 1: SAFETY, STRENGTH AND DURABILITY REQUIREMENTS (EXCEPT FOR CLAUSE 5.3)	PASS
DIN EN 747-2: 2024- FURNITURE — BUNK BEDS AND HIGH BEDS PART 2: TEST METHODS BS EN 747-2:2024	

Signed for and on behalf of
 SGS-CSTC Standards Technical Services (Shanghai) Co., Ltd.

Arron Lou
 Authorized Signatory



Unless otherwise agreed in writing, this document is issued by the Company subject to its General Conditions of Service printed overleaf, available on request or accessible at <https://www.sgs.com/en/Terms-and-Conditions>. Attention is drawn to the limitation of liability, indemnification and jurisdiction issues defined therein. Any holder of this document is advised that information contained hereon reflects the Company's findings at the time of its intervention only and within the limits of Client's instructions, if any. The Company's sole responsibility is to its Client and this document does not exonerate parties to a transaction from exercising all their rights and obligations under the transaction documents. This document cannot be reproduced except in full, without prior written approval of the Company. Any unauthorized alteration, forgery or falsification of the content or appearance of this document is unlawful and offenders may be prosecuted to the fullest extent of the law. Unless otherwise stated the results shown in this test report refer only to the sample(s) tested and such sample(s) are retained for 30 days only.

Attention: To check the authenticity of testing /inspection report & certificate, please contact us at telephone: (86-755) 8307 1443, or email: CN.Doecheck@sgs.com

SGS-CSTC Standards Technical Services (Shanghai) Co., Ltd.
 Hardlines

4th Building, No.889, Yishan Road, Xuhui District, Shanghai, China 200233 | 3rd Building, Lane 3999, Xiupu Road, Pudong District, Shanghai China 201315 t (86) 400 960 9661 www.sgs.com.cn
 中国·上海·徐汇区宜山路889号4号楼 邮编: 200233 | 中国·上海·浦东新区秀浦路3999弄3号楼 邮编: 201315 t (86) 400 960 9661 sgs.china@sgs.com

Test Report

No.: SHHL241006191201FT

Date: OCT. 28, 2024

Page: 2 of 6

Test Conducted:

DIN EN 747-1: 2024 & EN 747-2: 2024

Type of Furniture : Furniture - Bunk beds and high beds

Nos. of Specimen : 1 pc.

Test Result : Pass. Details shown as following table

Clause	Test Items	Result	Note
4	Safety Requirement		
4.1	Construction		
4.1.1	General	Pass	---
4.1.2	Accessible holes gaps and openings	---	---
4.1.2.1	General	Pass	---
4.1.2.2	Head entrapment on the outside of the bunk bed/high bed	Pass	---
4.1.3	Bed base(s)	---	---
4.1.3.1	Dimensional requirements	Pass	---
4.1.3.2	Gaps and openings	Pass	---
4.1.3.3	Ventilation	Pass	---
4.1.3.4	Structural integrity	Pass	---
4.1.4	Safety barriers around upper beds	---	---
4.1.4.1	General requirements	Pass	---
4.1.4.2	Dimensional requirements	Pass	---
4.1.4.3	Gaps and openings	Pass	---
4.1.4.4	Structural integrity	Pass	---
4.1.5	Means of access	---	---
4.1.5.1	General	Pass	---
4.1.5.2	Gaps and openings	Pass	---
4.1.5.3	Ladders	Pass	---
4.1.5.4	Stairs and handrails	---	---
4.1.5.4.1	General requirements	N/A	# 1
4.1.5.4.2	Dimensional requirement	N/A	# 1
4.1.5.4.3	Structural integrity	N/A	# 1



Unless otherwise agreed in writing, this document is issued by the Company subject to its General Conditions of Service printed overleaf, available on request or accessible at <https://www.sgs.com/en/Terms-and-Conditions>. Attention is drawn to the limitation of liability, indemnification and jurisdiction issues defined therein. Any holder of this document is advised that information contained hereon reflects the Company's findings at the time of its intervention only and within the limits of Client's instructions, if any. The Company's sole responsibility is to its Client and this document does not exonerate parties to a transaction from exercising all their rights and obligations under the transaction documents. This document cannot be reproduced except in full, without prior written approval of the Company. Any unauthorized alteration, forgery or falsification of the content or appearance of this document is unlawful and offenders may be prosecuted to the fullest extent of the law. Unless otherwise stated the results shown in this test report refer only to the sample(s) tested and such sample(s) are retained for 30 days only.

Attention: To check the authenticity of testing /inspection report & certificate, please contact us at telephone: (86-755) 8307 1443, or email: CN.Doccheck@sgs.com

Test Report

No.: SHHL241006191201FT

Date: OCT. 28, 2024

Page: 3 of 6

4.1.5.5	Additional requirements for access platforms	---	---
4.1.5.5.1	General requirement	N/A	# 1
4.1.5.5.2	Dimensional requirement	N/A	# 1
4.1.5.5.3	Gaps and openings	N/A	# 1
4.1.5.5.4	Structural integrity	N/A	# 1
4.1.6	Shear and squeeze points	---	---
4.1.6.2	Shear and squeeze points when setting up and folding	Pass	---
4.1.6.3	Shear and squeeze points under the influence of powered mechanisms	N/A	# 1
4.1.6.4	Shear and squeeze points during use	Pass	---
4.1.7	All other accessible holes, gaps or openings	Pass	---
4.2	Strength of ladder or other means of access: Attachment, deflection and strength	Pass	---
4.3	Strength of frame and fastenings	Pass	---
4.4	Stability	Pass	---
4.5	Fastening of the upper bed to the lower bed	Pass	---
5	Product information	---	---
5.1	Marking	Pass	# 2
5.2	Instructions for use	Pass	# 2
5.3	Purchase information	N/C	# 3

Notes : # 1- N/A means not applicable to this product design.
 # 2- Only English version was checked.
 # 3- N/C means not conducted as per client's requirement.

Remark:

- Since the data and / or information above division line of front page is provided by the applicant, the relevant results or conclusions of this report are only made for these data and / or information, SGS shall not be responsible for the authenticity and integrity of such data and information and the validity of the results and / or conclusions arising therefrom. Testing results only apply to the sample as received.
- The declaration of conformity is based on acceptance limits chosen based on simple acceptance ($w = 0, AL = TL$).

Statements of conformity are reported as:

Passed - The measured values were observed in tolerance at the points tested.

Failed - One or more measured values were observed out of tolerance at the points tested.



Unless otherwise agreed in writing, this document is issued by the Company subject to its General Conditions of Service printed overleaf, available on request or accessible at <https://www.sgs.com/en/Terms-and-Conditions>. Attention is drawn to the limitation of liability, indemnification and jurisdiction issues defined therein. Any holder of this document is advised that information contained hereon reflects the Company's findings at the time of its intervention only and within the limits of Client's instructions, if any. The Company's sole responsibility is to its Client and this document does not exonerate parties to a transaction from exercising all their rights and obligations under the transaction documents. This document cannot be reproduced except in full, without prior written approval of the Company. Any unauthorized alteration, forgery or falsification of the content or appearance of this document is unlawful and offenders may be prosecuted to the fullest extent of the law. Unless otherwise stated the results shown in this test report refer only to the sample(s) tested and such sample(s) are retained for 30 days only.

Attention: To check the authenticity of testing / inspection report & certificate, please contact us at telephone: (86-755) 8307 1443, or email: CN.Doccheck@sgs.com

Sample Photo:

Received Sample (view 1)



Received Sample (view 2)



Received Sample (view 3)



Marking

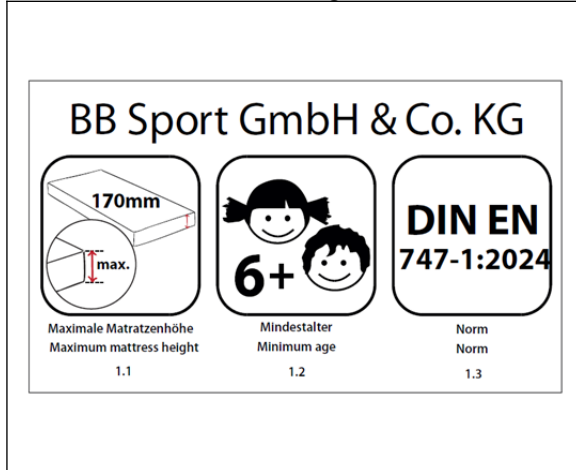

Instruction (view 1)

IMPORTANT – READ CAREFULLY AND KEEP IT SAFE
The manufacturer's instructions must always be followed!

WARNING: The upper bed is not suitable for children under six years due to the risk of injury from falls.

WARNING: Bunk beds / High beds can present a serious risk of injury from strangulation if not used correctly. Never allow or allow items to any part of the bunk bed / High bed that are not designed to be used with the bed, for example, but not limited to ropes, strings, cords, hooks, belts and bags.

WARNING: Children can become trapped between the bed and the wall, a roof slab, the ceiling, adjoining pieces of furniture or a cupboard and the like. To avoid risk of serious injury the distance between the top safety barrier and the adjoining structure must not exceed 75 mm or must be more than 230 mm.

WARNING: Do not use this bunk bed / High bed if any structural part is broken or missing.

WARNING: Always ensure the platform and the ladder / stairs are permanently attached to this bunk bed before use.

WARNING: This product must be attached to a wall or building structure.

Recommended size of mattress: 2000 x 900 mm

Information to the markings on the bed:



1.1 The maximum thickness of the mattress must not exceed 170 mm.
1.2 The minimum age for using the upper bed is 6 years.
1.3 Applicable Standard: DIN EN 747-1:2024

Regularly check the tightness of all connecting elements!

Adequate ventilation of the room is necessary in order to keep the air humidity low and prevent mould formation in and around the bed.

BB Sport GmbH & Co. KG · Seidenbergstraße 24 · 80513 Tregenz am Inn · Germany
Phone: 0049 8153 980264

Instruction (view 2)

WICHTIG – SORGFÄLTIG LESEN UND AUFBEWAHREN
Die Anleitungen des Herstellers sind stets zu befolgen!

WARNUNG: Hochbetten und das obere Bett von Eigenbetten sind für Kinder unter 6 Jahren aufgrund der Verletzungsgefahr durch Herabfallen nicht geeignet.

WARNUNG: Bei unangemessenen Gebrauch können Eigenbetten und Hochbetten eine ernsthafte Verletzungsgefahr durch strangulieren darstellen. Gegenstände, die nicht für den Gebrauch mit dem Bett bestimmt sind, dürfen niemals an einem Teil des Eigenbettes befestigt oder aufgehängt werden, dies gilt z. B., aber nicht ausschließlich, für Seile, Schnüre, Kordeln, Haken, Gürtel und Taschen.

WARNUNG: Kinder können zwischen dem Bett und der Wand, einer Dachplatte, der Zimmerdecke, angrenzenden Einrichtungsgegenständen (z.B. Schränken) usw. eingeklemmt werden. Um ernsthafte Verletzungsgefahr zu vermeiden, darf der Abstand zwischen der Oberkante der Aufbautrennung und der angrenzenden Struktur 75 mm nicht überschreiten oder muss größer sein als 230 mm.

WARNUNG: Das Eigenbett / Hochbett darf nicht benutzt werden, wenn ein konstruktives Bauteil beschädigt ist oder fehlt.

WARNUNG: Vergewissern Sie sich vor dem Gebrauch immer, dass die Plattform und die Leiter / Treppe fest mit dem Eigenbett verbunden sind.

WARNUNG: Dieses Produkt muss an einer Wand oder einer Gebäudestruktur befestigt werden.

Empfohlene Matratzengröße: 2000 x 900 mm

Informationen zu den Kennzeichnungen am Bett:



1.1 Die Matratzenstärke der Matratze darf 170 mm nicht überschreiten.
1.2 Der Mindestalter des oberen Bettes beträgt 6 Jahre.
1.3 Angewandte Norm: DIN EN 747-1:2024

Der feste Anstieg oder Verbindungselemente ist regelmäßig zu überprüfen!
Eine ausreichende Raumlüftung ist notwendig, um die Luftfeuchtigkeit niedrig zu halten und Schimmelbildung in und um das Bett zu vermeiden.

BB Sport GmbH & Co. KG · Seidenbergstraße 24 · 80513 Tregenz am Inn · Deutschland
Telefon: 0049 8153 980264

Instruction (view 3)

Montafox

AR. ID: 16470



**Aufbauanleitung
Assembly instruction**

WICHTIG: BITTE SORGFÄLTIG LESEN – FÜR SPÄTERE VERWENDUNG AUFBEWAHREN

WARNUNG: Hochbetten und das obere Bett von Eigenbetten sind für Kinder unter 6 Jahren aufgrund der Verletzungsgefahr durch Herabfallen nicht geeignet.

WARNUNG: Bei unangemessenen Gebrauch können Eigenbetten und Hochbetten eine ernsthafte Verletzungsgefahr durch strangulieren darstellen. Gegenstände, die nicht für den Gebrauch mit dem Bett bestimmt sind, dürfen niemals an einem Teil des Eigenbettes befestigt oder aufgehängt werden, dies gilt z. B., aber nicht ausschließlich, für Seile, Schnüre, Kordeln, Haken, Gürtel und Taschen.

WARNUNG: Kinder können zwischen dem Bett und der Wand, einer Dachplatte, der Zimmerdecke, angrenzenden Einrichtungsgegenständen (z.B. Schränken) usw. eingeklemmt werden. Um ernsthafte Verletzungsgefahr zu vermeiden, darf der Abstand zwischen der Oberkante der Aufbautrennung und der angrenzenden Struktur 75 mm nicht überschreiten oder muss größer sein als 230 mm.

WARNUNG: Das Eigenbett / Hochbett darf nicht benutzt werden, wenn ein konstruktives Bauteil beschädigt ist oder fehlt.

WARNUNG: Vergewissern Sie sich vor dem Gebrauch immer, dass die Plattform und die Leiter / Treppe fest mit dem Eigenbett verbunden sind.

WARNUNG: Dieses Produkt muss an einer Wand oder einer Gebäudestruktur befestigt werden.

Instruction (view 4)

IMPORTANT – READ CAREFULLY – RETAIN FOR FUTURE REFERENCE
The upper bed is not suitable for children under six years due to the risk of injury from falls.



WARNING: Bunk beds / High beds can present a serious risk of injury from strangulation if not used correctly. Never allow or allow items to any part of the bunk bed / High bed that are not designed to be used with the bed. To ensure that no ropes, strings, cords, hooks, belts and bags.

WARNING: Children can become trapped between the bed and the wall, a roof slab, the ceiling, adjoining pieces of furniture or a cupboard and the like. To avoid risk of serious injury the distance between the top safety barrier and the adjoining structure must not exceed 75 mm or must be more than 230 mm.

WARNING: Do not use this bunk bed / High bed if any structural part is broken or missing.

WARNING: Always ensure the platform and the ladder / stairs are permanently attached to this bunk bed before use.

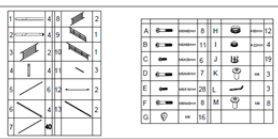
WARNING: The product must be attached to a wall or building structure.



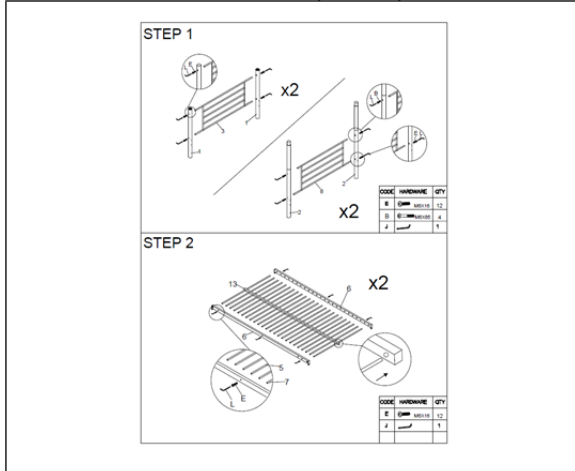

Unless otherwise agreed in writing, this document is issued by the Company subject to its General Conditions of Service printed overleaf, available on request or accessible at <https://www.sgs.com/en/Terms-and-Conditions>. Attention is drawn to the limitation of liability, indemnification and jurisdiction issues defined therein. Any holder of this document is advised that information contained hereon reflects the Company's findings at the time of its intervention only and within the limits of Client's instructions, if any. The Company's sole responsibility is to its Client and this document does not exonerate parties to a transaction from exercising all their rights and obligations under the transaction documents. This document cannot be reproduced except in full, without prior written approval of the Company. Any unauthorized alteration, forgery or falsification of the content or appearance of this document is unlawful and offenders may be prosecuted to the fullest extent of the law. Unless otherwise stated the results shown in this test report refer only to the sample(s) tested and such sample(s) are retained for 30 days only.

Instruction (view 5)

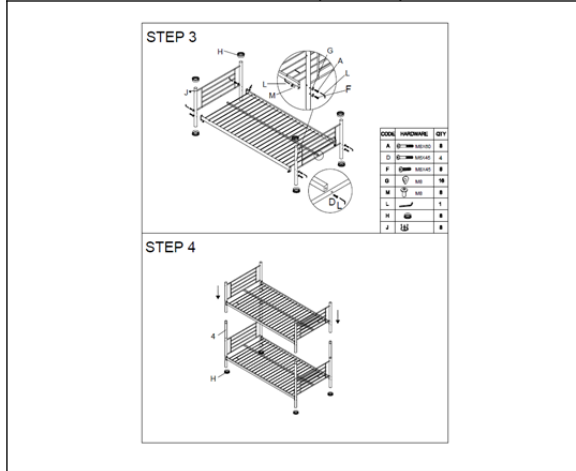

Instruction (view 6)



Instruction (view 7)

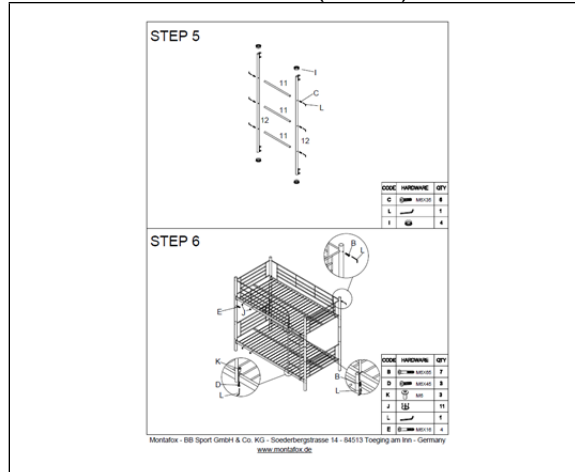

SGS authenticate the photo on original report only

End of Report



Unless otherwise agreed in writing, this document is issued by the Company subject to its General Conditions of Service printed overleaf, available on request or accessible at <https://www.sgs.com/en/Terms-and-Conditions>. Attention is drawn to the limitation of liability, indemnification and jurisdiction issues defined therein. Any holder of this document is advised that information contained hereon reflects the Company's findings at the time of its intervention only and within the limits of Client's instructions, if any. The Company's sole responsibility is to its Client and this document does not exonerate parties to a transaction from exercising all their rights and obligations under the transaction documents. This document cannot be reproduced except in full, without prior written approval of the Company. Any unauthorized alteration, forgery or falsification of the content or appearance of this document is unlawful and offenders may be prosecuted to the fullest extent of the law. Unless otherwise stated the results shown in this test report refer only to the sample(s) tested and such sample(s) are retained for 30 days only.

Attention: To check the authenticity of testing / inspection report & certificate, please contact us at telephone: (86-755) 8307 1443, or email: CN.Doccheck@sgs.com

4th Building, No.888, Yishan Road, Xuhui District, Shanghai, China 200233 | 3rd Building, Lane 3899, Xiupu Road, Pudong District, Shanghai China 201315 t (86) 400 960 9661 www.sgs.com.cn
中国·上海·徐汇区宜山路888号4号楼 邮编: 200233 | 中国·上海·浦东新区秀浦路3999弄3号楼 邮编: 201315 t (86) 400 960 9661 sgs.china@sgs.com