

# U4-2147



## 4-Channel Wideband Up/Down-Converter 21-47 GHz

### Description:

**U4-2147** is a 4-channel broadband 21-47 GHz double-balanced up/down-converter with a typical conversion gain of 21 dB (Rx) and 12 dB (Tx), a nominal P1dB of 8 dBm (Tx), and a noise figure of 8-10 dB. The single-sideband rejection (SSBR) and image rejection ratio (IRR) are 35-40 dBc over the entire frequency range. The differential IF signal is 2-10 GHz, and the LO range is 8-22 GHz (x2 LO mode) and 4-11 GHz (x4 LO mode). The x2 or x4 LO leakage is < -30 dBm at the RF port and < -50 dBm at the IF ports. The DC power requirements is 1.2 A (Rx) /1.8 A (Tx) with a +3.5 V supply for 4-channel operation. A fast-switch mode allows Tx/Rx switching in 100 ns or less. The SPI control with USB allows adjustments of gain/NF/IP1dB/OP1dB as well as optimization of SSBR and IRR (> 40dBc) and LO leakage (<-35 dBm). Preloaded states (8 different states) are also available without USB connection for easier use.

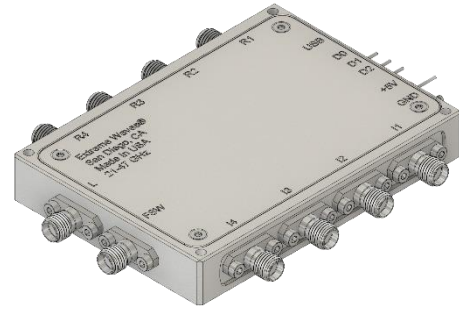

- Unit available with 1 RF channels (U1-2147) and 2 RF channels (U2-2147)
- Unit available at 18-55 GHz with 1,2,4 RF channels

### Features:

- Broadband Operation
- High SSBR and IRR
- Tx/Rx functionality

### Applications:

- Digital Beamforming
- Multi-band 5G
- SIGINT, Electronic Warfare

### Functional Block Diagram:

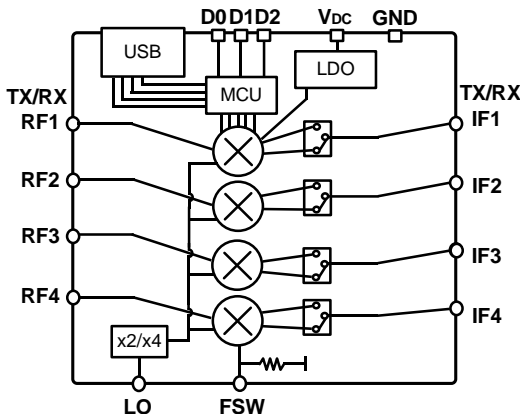

### Mechanical Specifications:

Item	Specification
RF Port	2.4 mm
LO Port	SMA
IF Ports	SMA
FSW Port	SMA
Bias & Digital	Solder Pin
USB	Micro B Receptacle
Case	Aluminum
Weight	200 g
Size	9 cm (W) x 6 cm (L) x 1.3 cm (H)
Hermetic	No / Available upon demand

# U4-2147



Port Diagram:

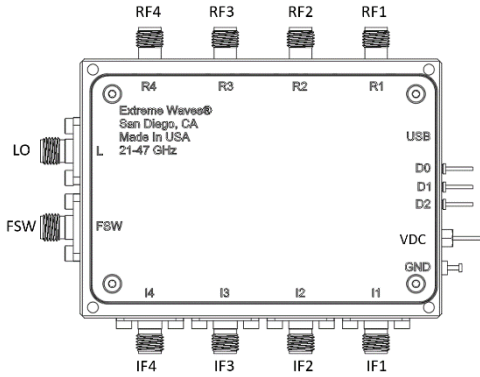

Control Diagram:

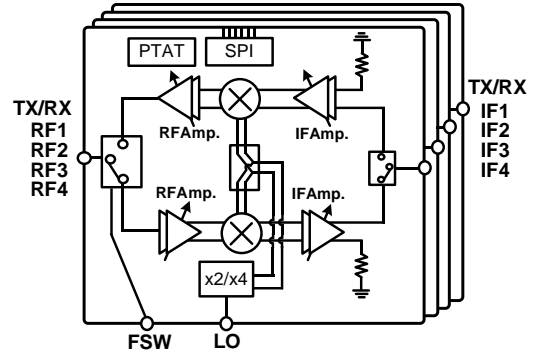

Port Functions and Absolute Maximum Ratings:

Port	Description	Equivalent Circuit	Maximum Rating
RF1 RF2 RF3 RF4	<ul style="list-style-type: none"> <li>➤ RF input (Rx) / RF output (Tx)</li> <li>➤ Built-in DC short for ESD</li> <li>➤ NO DC voltage allowed on RF port</li> </ul>		+7 dBm (in Rx mode)
LO	<ul style="list-style-type: none"> <li>➤ LO input</li> <li>➤ AC coupled, with built-in RF choke and DC blocking capacitor for ESD</li> </ul>		+10 dBm
FSW	<ul style="list-style-type: none"> <li>➤ Port to switch Tx/Rx mode in 100 ns</li> <li>➤ Rx mode in default</li> <li>➤ Zin = 200 Ω</li> </ul>		5 V
IF1 IF2 IF3 IF4	<ul style="list-style-type: none"> <li>➤ IF input (Tx) /output (Rx)</li> <li>➤ AC coupled</li> </ul>		+ 10 dBm <sup>1</sup>
VDC	<ul style="list-style-type: none"> <li>➤ Voltage supply</li> </ul>		6 V
GND	<ul style="list-style-type: none"> <li>➤ Ground</li> </ul>		-
D0 D1 D2	<ul style="list-style-type: none"> <li>➤ 3-bit control for 8 preloaded states</li> <li>➤ High in default</li> </ul>		5 V

1. Do not put power in IF ports in the RX mode!

## Electrical Specifications:

Parameter	Minimum	Typical	Maximum
RF Frequency (GHz)	21		47
IF Frequency (GHz)	2		10
LO Frequency (GHz)	8 (x2 LO)		22 (x2 LO)
	4 (x4 LO)		11 (x4 LO)
LO Input Power (dBm)		0	10
FSW Switch Operation (V)	2	3.3	5
DC Voltage (V)		3.5	6
DC Current (mA)		1200 (Rx), 1800 (Tx)	1400 (Rx), 2000 (Tx)
D0, D1, D2 Pin Operation (V)	2	3.3	5
Operating Temperature (°C)		27	65

Receive Mode		
Parameter	Condition	Nominal
Conversion Gain (dB)	IF < 3.5 GHz	22
	IF @ 6 GHz	21
	IF @ 10 GHz	19
Gain Control Range (dB)	RF Amplifier	13
Gain Control Range (dB)	IF Amplifier	15
SSB Noise Figure (dB)	Max. Gain	8-10
	Min. Gain	18-20
Input P1dB (dBm)	Max. Gain	-23 to -20
	Min. Gain	-7 to -5
Input IP3 (dBm)	Max. Gain	-13 to -10
	Min. Gain	+3 to +5
IRR vs RF Freq. (dBc) <sup>1</sup> IRR vs IF Freq. (dBc) <sup>1</sup>	Max. Gain	>35
	@ 28 GHz	>35
	@ 39 GHz	>35
LO at IF port (dBm)	Max. Gain	<-50
All other spurs at IF port (dBm) <sup>3</sup>	Max. Gain	<-55
Tx/Rx Switching (ns)		<100
Coupling Between Ports (dB)		<-40

Transmit Mode		
Parameter	Condition	Nominal
Conversion Gain (dB)	IF < 3.5 GHz	15
	IF @ 6 GHz	14
	IF @ 10 GHz	12
Gain Control Range (dB)	RF Amplifier	15
Gain Control Range (dB)	IF Amplifier	15
SSB Noise Figure (dB)	Max. Gain	19-20
Output P1dB (dBm)	Max. Gain	5-11
Psat (dBm)	Max. Gain	7-12
Output IP3 (dBm)	Max. Gain	18-24
SSBR vs RF Freq. (dBc) <sup>1</sup> SSBR vs IF Freq. (dBc) <sup>1</sup>	Max. Gain	>35
	@ 28 GHz	>35
	@ 39 GHz	>35
x2LO at RF port (dBm) <sup>2</sup>	Max. Gain	-35 to -30
All other spurs at RF port (dBm) <sup>3</sup>	Max. Gain	<-32
Tx/Rx Switching (ns)		<100
Coupling Between Ports (dB)		<-40

### Notes:

1. Uncalibrated IRR and SSBR. Higher IRR and SSBR available for a narrow frequency range using SPI control.
2. Uncalibrated. Better values available using SPI control.
3. Recommend x2 LO mode for minimal spur generation. ( $2f_{LO}$ ) and ( $2f_{LO}+2f_{IF}$ ) are the highest spurs.

- All data presented is collected from a sample lot. Actual data may vary unit to unit.
- Extreme Waves, Inc. reserves the right to change the information presented without notice.
- Exceeding maximum voltage rating will cause damage or degrade the electrical specifications.

## Key Electrical Performance Plots

Condition of Figure 1 through Figure 6: IF=4GHz, x4 LO mode

Condition of Figure 7 and Figure 8: RF=29GHz, x4 LO mode

