

U1-2147



Wideband Up/Down-Converter 21-47 GHz

Description:

U1-2147 is a broadband 21-47 GHz double-balanced up/down-converter with a typical conversion gain of 22 dB (Rx) and 13 dB (Tx), a nominal P1dB of 8 dBm (Tx), and a noise figure of 8-10 dB. The single-sideband rejection (SSBR) and image rejection ratio (IRR) are 35-40 dBc over the entire frequency range. The differential IF signal is 2-10 GHz, and the LO range is 8-22 GHz (x2 LO mode) and 4-11 GHz (x4 LO mode). The x2 or x4 LO leakage is < -30 dBm at the RF port and < -50 dBm at the IF ports. The DC power requirements is 300 mA (Rx) / 450 mA (Tx) with a +3.5 V supply. A fast-switch mode allows Tx/Rx switching in 100 ns or less. The SPI control with USB allows adjustments of gain/NF/IP1dB/OP1dB as well as optimization of SSBR and IRR (> 40 dBc) and LO leakage (< -35 dBm). Preloaded states (8 different states) are also available without USB connection for easier use.

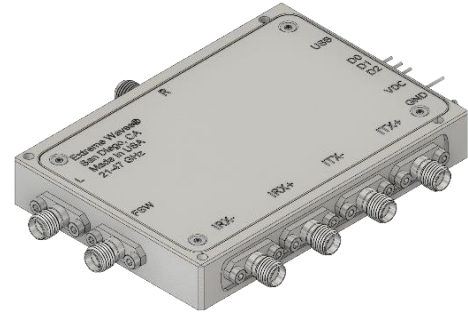

- Unit available with 2 RF channels (U2-2147) and 4 RF channels (U4-2147)
- Unit available at 18-55 GHz with 1,2,4 RF channels

Features:

- Broadband Operation
- High SSBR and IRR
- Tx/Rx functionality

Applications:

- Digital Beamforming
- Multi-band 5G
- SIGINT, Electronic Warfare

Functional Block Diagram:

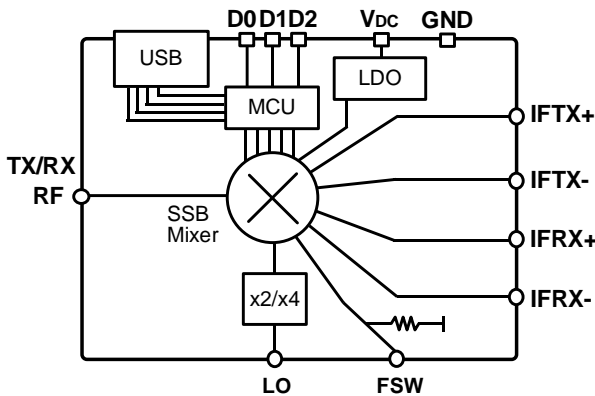

Mechanical Specifications:

Item	Specification
RF Port	2.4 mm
LO Port	SMA
IF Ports	SMA
FSW Port	SMA
Bias & Digital	Solder Pin
USB	Micro B Receptacle
Case	Aluminum
Weight	150 g
Size	8 cm (W) x 6 cm (L) x 1.3 cm (H)
Hermetic	No / Available upon demand

U1-2147



Port Diagram:

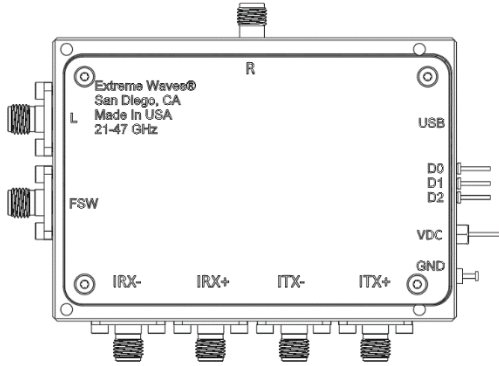

Control Diagram:

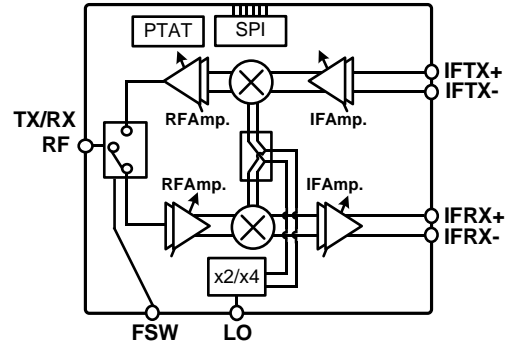

Port Functions and Absolute Maximum Ratings:

Port	Description	Equivalent Circuit	Maximum Rating
RF	<ul style="list-style-type: none"> ➤ RF input (Rx) / RF output (Tx) ➤ Built-in DC short for ESD ➤ NO DC voltage allowed on RF port 		+7 dBm (in Rx mode)
LO	<ul style="list-style-type: none"> ➤ LO input ➤ AC coupled, with built-in RF choke and DC blocking capacitor for ESD 		+10 dBm
FSW	<ul style="list-style-type: none"> ➤ Port to switch Tx/Rx mode in 100 ns ➤ Rx mode in default ➤ Zin = 200 Ω 		5 V
IFTX+/- IFRX+/-	<ul style="list-style-type: none"> ➤ Differential IF input (Tx) /output (Rx) ➤ AC coupled 		+ 10 dBm (IFTX) + 10 dBm (IFRX) ¹
VDC	<ul style="list-style-type: none"> ➤ Voltage supply 		6 V
GND	<ul style="list-style-type: none"> ➤ Ground 		-
D0 D1 D2	<ul style="list-style-type: none"> ➤ 3-bit control for 8 preloaded states ➤ High in default 		5 V

1. Do not put power in IFRX+/- ports in the RX mode!

Electrical Specifications:

Parameter	Minimum	Typical	Maximum
RF Frequency (GHz)	21		47
IF Frequency (GHz)	2		10
LO Frequency (GHz)	8 (x2 LO)		22 (x2 LO)
	4 (x4 LO)		11 (x4 LO)
LO Input Power (dBm)		-10	0
FSW Switch Operation (V)	2	3.3	5
DC Voltage (V)		3.5	6
DC Current (mA)		300 (Rx), 450 (Tx)	350 (Rx), 500 (Tx)
D0, D1, D2 Pin Operation (V)	2	3.3	5
Operating Temperature (°C)		27	65

Receive Mode		
Parameter	Condition	Nominal
Conversion Gain (dB) ¹	IF < 3.5 GHz	23
	IF @ 6 GHz	22
	IF @ 10 GHz	20
Gain Control Range (dB)	RF Amplifier	13
Gain Control Range (dB)	IF Amplifier	15
SSB Noise Figure (dB)	Max. Gain	8-10
	Min. Gain	18-20
Input P1dB (dBm)	Max. Gain	-23 to -20
	Min. Gain	-7 to -5
Input IP3 (dBm)	Max. Gain	-13 to -10
	Min. Gain	+3 to +5
IRR vs RF Freq. (dBc) ² IRR vs IF Freq. (dBc) ²	Max. Gain	>35
	@ 28 GHz	>35
	@ 39 GHz	>35
LO at IF port (dBm)	Max. Gain	-50
All other spurs at IF port (dBm) ⁴	Max. Gain	<-55
Tx/Rx Switching (ns)		<100

Transmit Mode		
Parameter	Condition	Nominal
Conversion Gain (dB) ¹	IF < 3.5 GHz	16
	IF @ 6 GHz	15
	IF @ 10 GHz	13
Gain Control Range (dB)	RF Amplifier	15
Gain Control Range (dB)	IF Amplifier	15
SSB Noise Figure (dB)	Max. Gain	19-20
Output P1dB (dBm)	Max. Gain	5-11
Psat (dBm)	Max. Gain	7-12
Output IP3 (dBm)	Max. Gain	18-24
SSBR vs RF Freq. (dBc) ² SSBR vs IF Freq. (dBc) ²	Max. Gain	>35
	@ 28 GHz	>35
	@ 39 GHz	>35
x2LO at RF port (dBm) ³	Max. Gain	-35 to -30
All other spurs at RF port (dBm) ⁴	Max. Gain	<-32
Tx/Rx Switching (ns)		<100

Notes:

1. Single-ended IF output with 50 Ω termination on the other IF output. Differential IF mode results in +3 dB higher gain.
2. Uncalibrated IRR and SSBR. Higher IRR and SSBR available for a narrow frequency range using SPI control.
3. Uncalibrated. Better values available using SPI control.
4. Recommend x2 LO mode for minimal spur generation. (2f_{LO}) and (2f_{LO}+2f_F) are the highest spurs.

- All data presented is collected from a sample lot. Actual data may vary unit to unit.
- Extreme Waves, Inc. reserves the right to change the information presented without notice.
- Exceeding maximum voltage rating will cause damage or degrade the electrical specifications.

Key Electrical Performance Plots

Condition of Fig. 1 to Fig. 6: IF=4 GHz, x4 LO mode

Condition of Fig. 7 and Fig. 8: RF=29 GHz, x4 LO mode

