



SPECIFICATION

Model: QX1902VDL (H)

COMPRESSOR DRAWING LIST		
COMPRESSOR DIMENSIONS		QX19-WX
PERFORMANCE CURVE		QX19-TX
RUBBER GROMMET		QX19-35
GROMMET SLEEVE		QX19-36
ACCESSORY PARTS LIST		
ITEMS	Q'TY	REMARKS
Controller	1	
Rubber mat	3	
GROMMET SLEEVE	3	
Screw of Compressor	3	
Washer of Compressor	6	
Please in strict accordance with the drawings requirements and fittings required to install the compressor.		



ROTARY COMPRESSOR SPECIFICATION SHEET



Page : 1

Model: QX1902VDL(H)

APPLICATION

Sort	Portable Cooling System
Type	Portable type
Refrigerant	R-134a
Source of Electricity	Inverter for BLDC motor

NOMINAL PERFORMANCE

Conditions	HBP	LBP	
Rotation Number (rpm)	6,000	6,000	
Cooling capacity (Btu/h)	1,365	443	±10%
Max Current (A)	9	8.5	±10%
Current (A)	1 ~ 7	1 ~ 7	
Noise	48 ↓ dB(A)		0cm from surface, 4ways Ma
Vibration	≤0.65 m/s ²		Shell surface circumference

* Data may be changed. Only for reference.

Testing Conditions

		HBP	LBP
Condensing Temperature	130 °F	(54.4 °C)	130 °F (54.4 °C)
Evaporating Temperature	50 °F	(10.02 °C)	-10 °F (-23.3 °C)
Return Gas Temperature	73 °F	(22.7 °C)	90 °F (32.2 °C)
Liquid Temperature	115 °F	(46.1 °C)	90 °F (32.2 °C)
Ambient Temperature	95 °F	(35.0 °C)	90 °F (32.2 °C)
Compressor Cooling	1 m/s air cooling		
Controller	R&Y Inverter DB1510		

COMPRESSOR STRUCTURE & DATA

Type	Hermetic type motor compressor
Pressure Inside Closed Container	Discharging Pressure
Pump Type	Rotary type
Cylinder Volume	1.9cc/rev
Refrigerator Oil Type	POE
Injected Oil Volume	40 cc
Weight	725g(Including Refrigerator oil)
Suction Pipe Inner Diameter	6.54 mm
Discharge Pipe Inner Diameter	6.00 mm

ROTARY COMPRESSOR SPECIFICATION SHEET



Page : 2

Model: QX1902VDL(H)

MOTOR TYPE

Motor Type	BLDC Permanent Magnetic Motor
Pole/Phase No.	10 Pole 5 Phase
Magnetic Type	NdFeB
Insulation Class	E CATEGORY (Insulation Material PPS or PBT)
Winding Resistance (L-L)	0.3 (20°C) Ω

ELECTRICAL COMPONENTS

ELECTRICAL COMPONENTS	
Operation Inverter	Driver, D.C. voltage 24V (refer.)

POWER SUPPLY

Voltage	BLDC, DC 24V (Driver input)
Voltage Range	20V~32V

CHARACTERISTICS

Hydrostatic strength test (Low)	Strength pressure 7.45MPa (76kg/cm ²)
Hydrostatic strength test (High)	Strength pressure 16.2MPa (165kg/cm ²)
Residual moisture / Residual impurities	100mg Max / 100mg Max
Insulation Resistance	50 MΩ min. (with 500V D.C mega tester)
Withstand Voltage	@1800V-1sec(1250V-1min) Leakage current is less than 2.5mA

MOTOR SPECIFICATION SHEET



Model: QX1902VDL(H)	Page : 3

MOTOR SPECIFICATION

ITEM	MODEL	QX1902VDL(H)
	DC rink V	24V
Resistance (L-L)	Ω (at 20°C)	0.13
Voltage range(V)	DB1510	20 ~ 32
Speed (rpm)	Rated speed	2000 ~ 6000 rpm
Current (A)	Rated current	1 ~ 7 A
	Max Current	8.5 A
Frequency	Range	-

Evaporating Temperature °C	-18 ~24
Condensation Temperature °C	27 ~71
Max Compressor Temperature °C	130
Ambient Temperature °C	5 ~ 55
Suction Temperature °C	35
Noise dB	≤48
Driver Board	DB1510

ROTARY COMPRESSOR OUTDRAWING DIMENSION



Model: QX1902VDL(H)	Page : 4
	PART NO: QX19-WX

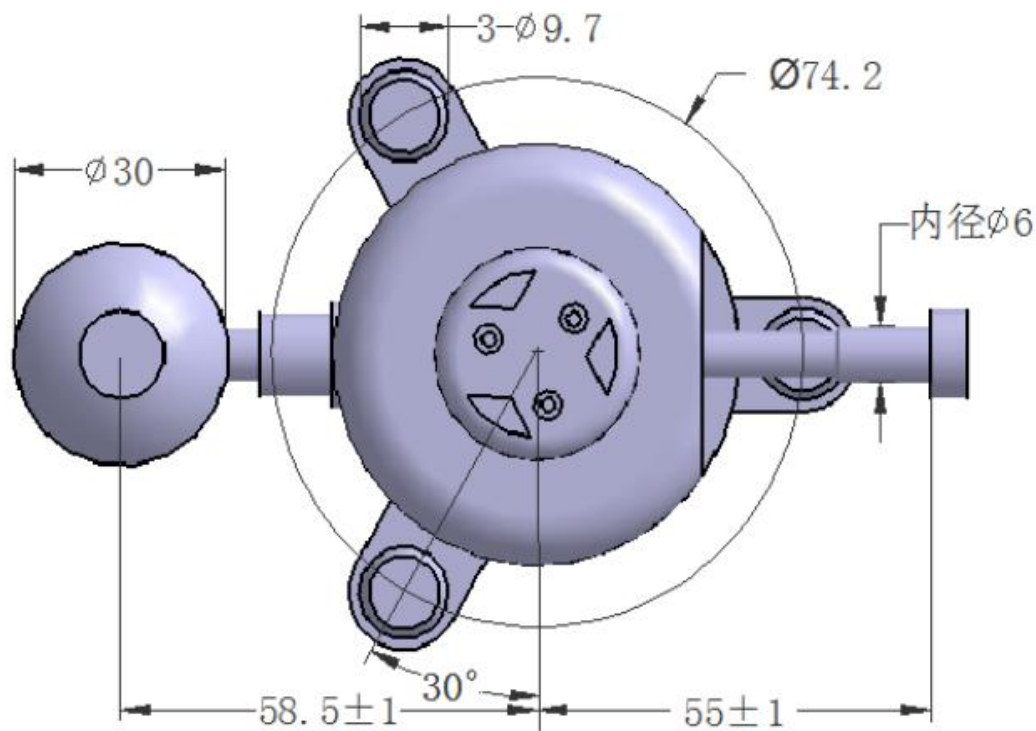
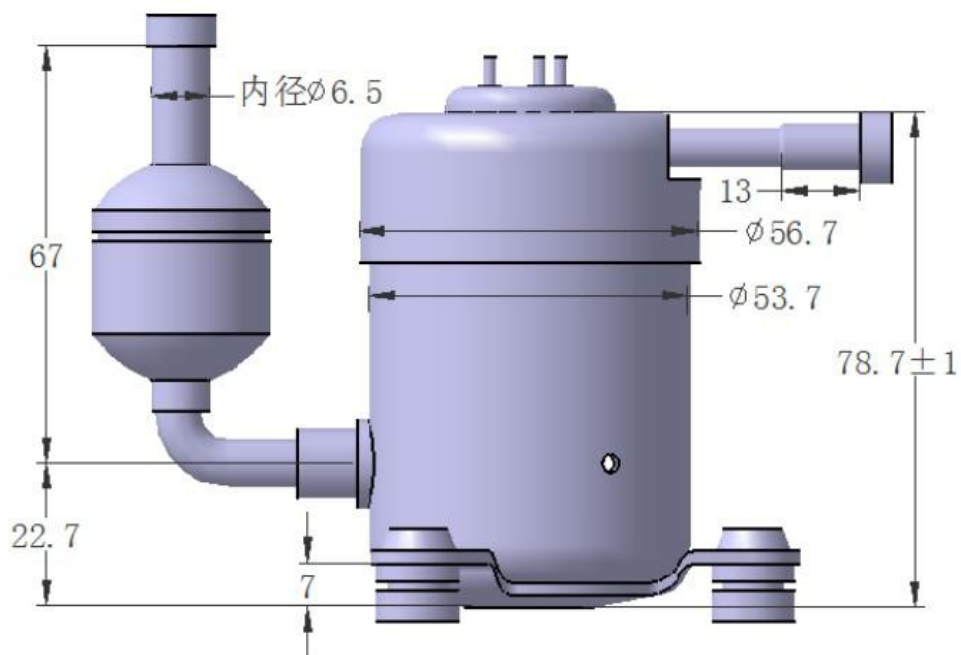

ROTARY COMPRESSOR ACCESSORIES DIMENSION



Model: QX1902VDL(H)

Page : 5

PART NO: QX19-35

PART NO: QX19-36

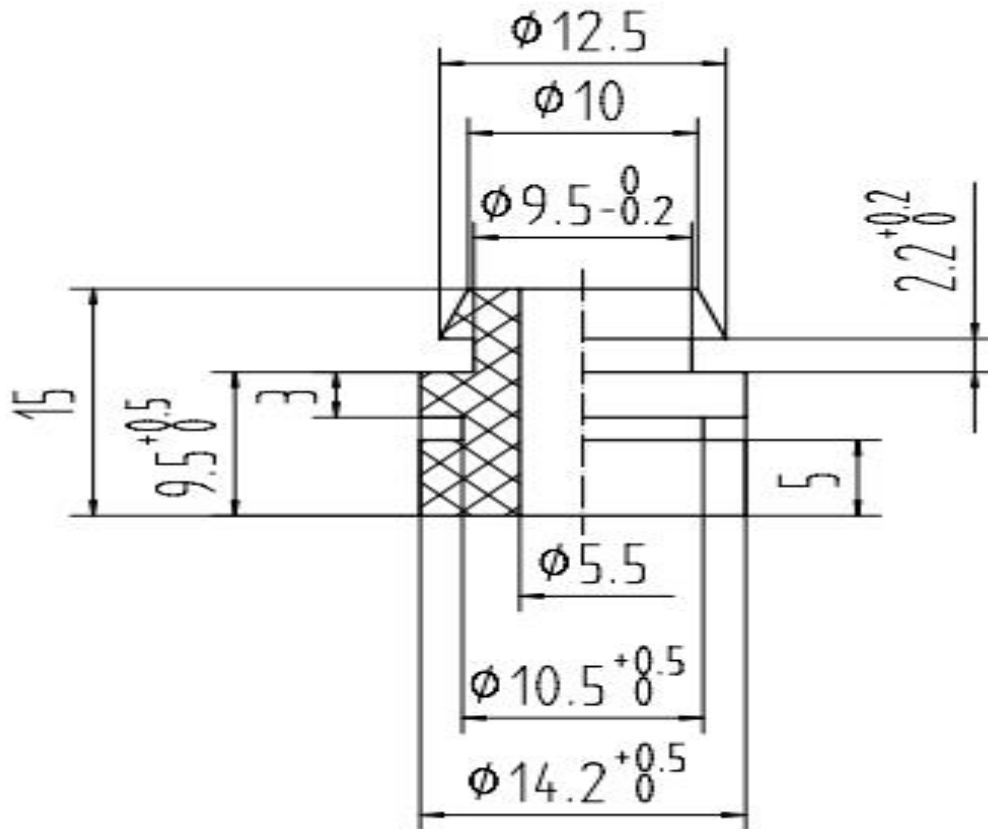

-Stuff : Rubber C

- Hardness : 50±

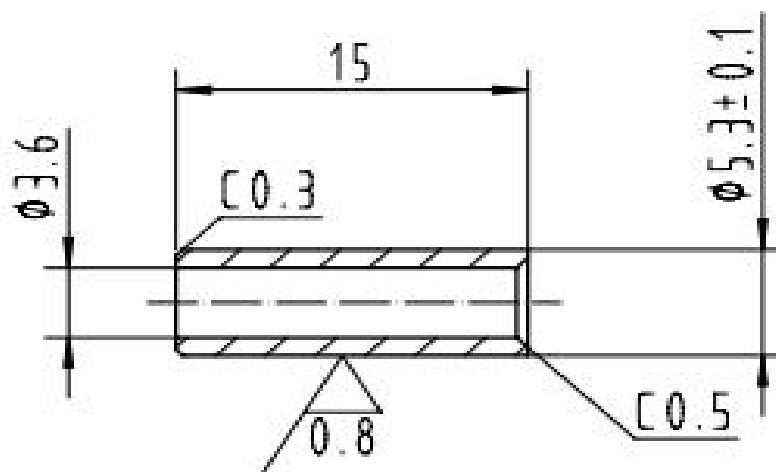

-Stuff : Rubber C

ROTARY COMPRESSOR PERFORMANCE LINE CHART



Model: QX1902VDL(H)

Page : 6

PART NO: QX19-TX

QX19VD Capacity



Evaporating Temperature °C Remark: Condensation Temperature: 38°C

QX19VD COP

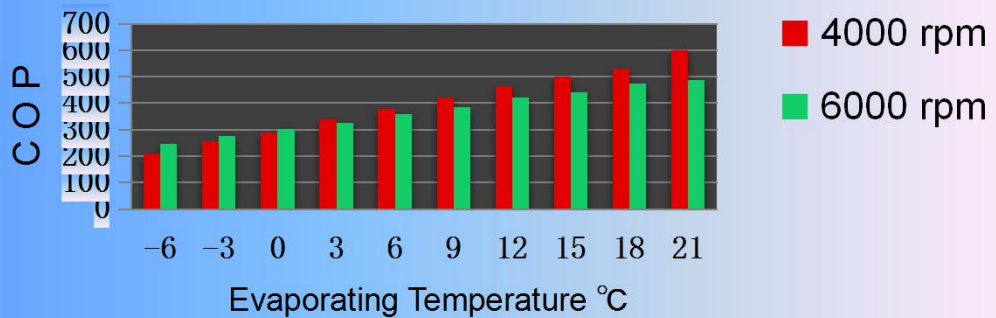

Remark: Condensation Temperature: 38°C

ROTARY COMPRESSOR INSTALLATION & APPLICATION



Page : 7

Model: QX1902VDL(H)

1. General

✘ Avoid installing the compressor in apparatus using refrigerants containing chlorine, such as R12, R22, R502, etc. Don't use filling devices that have been used for CFC or HCFC refrigerants before when filling the refrigerant.

✘ Don't use cleaning agents containing chlorine for cleaning circuits. Make sure that there is no residual chlorine left if they have to be used. Special attention: The content of chlorine related substances in refrigerating systems must be below 100 PPM of the total refrigerant gas filled.

✘ Use specified drying filters for HFC-134a only. Install the filters right after the sealing package is opened.

✘ Tubing used in systems must be clean and free from residual oil left from the manufacturing process.

2. Building vacuum

For building vacuum in the system the pumping should be made from both the high and low pressure sides. The vacuum should be below 0.35 mmHg

3. Filling of refrigerant

Filling of refrigerant must be from the high pressure end (condenser side).

4. Removing rubber plugs

The compressors are filled with high purity Nitrogen at 0.01 to 0.05 Mpa at the factory and the tubes are sealed with rubber plugs and thermal shrinking plastic tubes. The plug in discharge tube should be removed first to prevent oil from bursting out.

5. No soldering agent dusts, or other substances are allowed to get into the system when soldering the compressor to tubing's. Solder material should be low melting temperature to avoid oxidization on tubing's.

6. Mounting compressor

Use the rubber grommets supplied by the factory. Tilting should be controlled within 5°.

7. Starting

Compressors should not be started before they are installed into systems and refrigerant is filled. No running should be made when compressors are open to air. Allow for min. 3 minutes for internal pressure to be balanced between 2 starting.

8. Grounding for safety

Compressors are classified as Class I apparatus and have passed strict safety checking's prior to shipping out of the factory. Please grounding for safety.

9. Clean tubing's

Prevent metal chips, fibers, impurities, etc. from getting into tubing system when installing compressors. Install a 100 mesh metal filter in the tubing's

10. Refrigeration oil

The special refrigeration oil RL-68H compatible with HFC-134a is used for high reliability. The oil has excellent thermal stability and wear resistance properties. No other additional oil is allowed to be added into system.

ROTARY COMPRESSOR INSTALLATION & APPLICATION



Page : 8

Model: QX1902VDL(H)

11. Refrigerant

Use high purity (above 99.9% or above 99.95% if possible) HFC-134a only.

12. General requirements

- ※Compressors should be installed into refrigeration circuits within a year after they are manufactured
- ※Install compressors into refrigeration circuits within 30 minutes after breaking sealing to prevent moisture from getting into the compressors.
- ※Never pump vacuum in compressors alone.
- ※Never make idle runs on compressors.
- ※Do not power up compressors under vacuum conditions.
- ※Do not bump compressors heavily, let them fall or turn around violently when handling.
- ※Compressors should be stored in bays with good ventilation, free from the existence of corrosive gases. Do not store compressors at the same locations for corrosive stuffs containing acid or alkaline. Relative humidity should be lower than 80%.

13.Noise and vibration

No abnormal noise and vibration should occur during normal operation of the compressors

14. Insulation strength

- ※Insulation resistance: The resistance between the shell and the windings measured by a 500V insulation resistance tester is above 50 MΩ at normal conditions.
- ※Voltage endurance: No arc occurs between the shell and the windings within 1 second when a voltage of 1800 VAC/50Hz is applied.

15.Airtight and mechanical strength

- ※Pressure for testing air-tightness: No leakage and deformation are allowed at any part of the shell when dry air at 1.7 Mpa (absolute pressure) is filled into the compressor.
- ※Pressure for testing mechanical strength: 8 Mpa (absolute pressure), compressed air pumped into the compressor, no bursting of the shell should occur.

16.Residual water content inside the compressor is below 100 mg.Total amount of impurities inside the compressor is below 100 mg

17.Additional Specification

- ※Compressor should be installed in horizontal position. Compressor is normally worked in horizontal position but allow operated in vertical and other direction position for short time if the operation time is not to exceed 50 minute.
- ※Connection tubes between compressor and refrigerating systems must be make in flexibility state. You can put the tube around compressor one circle then join systems to avoid vibration caused by internal force in tubing.
- ※Cooling principle for rotary compressor is same as reciprocation compressor. Just connect properly with suction and discharge tube you can replace reciprocation compressor directly with rotary compressor. But make sure that discharge tube in rotary compressor is in high pressure end (condenser side) and so process tube do .So filling of refrigerant must be finished in one time and not like reciprocation

ROTARY COMPRESSOR INSTALLATION & APPLICATION



Model: QX1902VDL(H)	Page : 9
<p>compressor could slowly pour in from low pressure end. Particular bolt and nut is needed for fix rotary Compressor and refrigerator bottom plate. That means you have to made bolt and nut for yourself .In order to avoid sympathetic vibration we take advantage of nut should not pressure compressor tightly .you must be let compressors have some space for up and down move. To recommend you just to apply bolt not use nut.</p> <p>※After all the connection between compressor and systems finished properly you could choice some absorb materials south as damping rubber to wrap tubes for further reduce vibration.</p> <p>※ In processing to replace rotary compressor with reciprocation compressor .The systems' evaporator and condenser should not change but the capillary must be added 40-50CM based on original capillary length. The amount of refrigerant which will filling in system also need add 40-50 gram based on original refrigerant charging.</p> <p>※ Because rotary compressor' shell connected to systems' high pressure end so first time to start compressor the systems will not cooling or temperature change very slowly for a few minute.After some time passed the systems will be cooling rapidly (.the time for uncoiling time is not to exceed 15 minute).</p> <p>※The link between compressor and controller is through a wire and a plug .The controller can put anywhere in refrigerator. Be careful of not let controller too close near compressor. The compressor's speed could be adjusted by presetting the resistor of speed to 700Ω.If feeling noise and vibration you can select 270Ω.</p> <p>※when connecting the terminals with the controller, the plug should be connected on the horizontal level, otherwise the compressor will rotate on the wrong direction.</p>	