

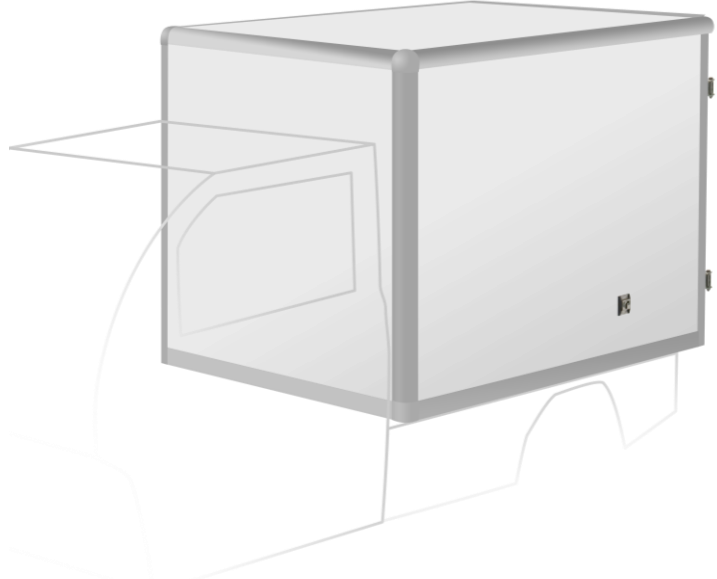

Our MISSION is to speed up the adoption of mass-market micro electric vehicles.



Cargo Box



Refrigerated Box

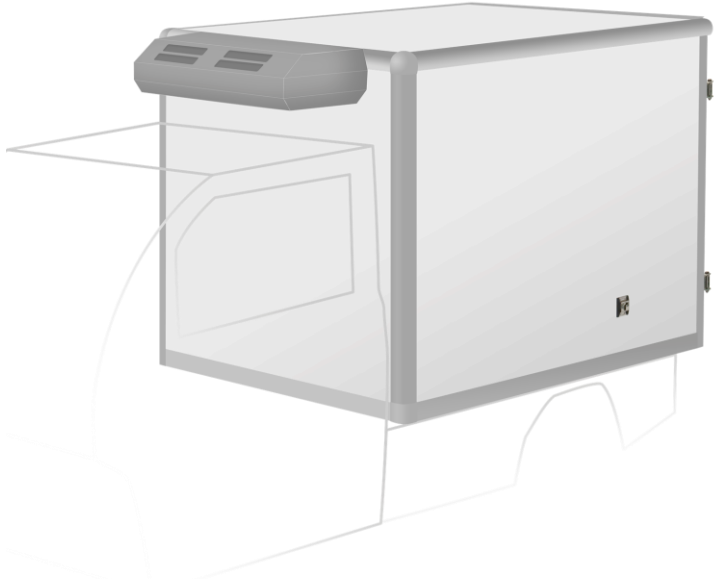

Tipper Alloy Tray



Pickup Alloy Tray



Pickup Steel Tray



DISCLAIMER:  
The battery pack capacity may/will degrade over time and usage. The actual driving range will vary depending on driving behaviors, charging intervals, driving speed, cargo load weight and weather conditions.  
The figures shown are for comparability purposes; only compare with other vehicles tested to the same technical procedures and similar vehicle weight class. The charging times are estimates. Charging stations must be Type 2 compatible. The permissible total cargo weight must not exceed. Technical specifications and data are valid at the time of publishing. The product images shown are for illustrative purposes only. Specifications are subject to change without prior notice.



● available | — not available | ○ optional

	Cargo Box	Refrigerated Box	Flatbed	Pickup	Tipper
<b>MAIN SPECIFICATIONS</b>					
Dimensions L × W × H (incl. mirror 1735 mm)	3700 × 1440 × 2100 mm	3700 × 1440 × 2100 mm	3600 × 1440 × 1750 mm	3700 × 1440 × 1800 mm	3700 × 1440 × 1800 mm
Driving range per WVTA (23 kWh / 11.52 kWh)	260 km / 130 km	240 km / —	260 km / 130 km	260 km / 130 km	260 km / 130 km
Battery pack options	23.04 kWh / 11.52 kWh	23.04 kWh / —	23.04 kWh / 11.52 kWh	23.04 kWh / 11.52 kWh	23.04 kWh / 11.52 kWh
Min. ground clearance 160 mm	●	●	●	●	●
Gross Vehicle Weight 1450 kg	●	●	●	●	●
Curb weight (23 kWh / 11.52 kWh)	845 kg / 760 kg	930 kg / —	850 kg / 760 kg	850 kg / 770 kg	850 kg / 770 kg
Top speed 75 km/h	●	●	●	●	●
Gradeability 25% (14.0°)	●	●	●	●	●
Charger EU Type 2	●	●	●	●	●
On-board charger (OBC)	3.3 kW / 2.2 kW	3.3 kW / —	3.3 kW / 2.2 kW	3.3 kW / 2.2 kW	3.3 kW / 2.2 kW
Charging time (20-80%)	≈ 5 / 4 h	≈ 5 h / —	≈ 5 / 4 h	≈ 5 / 4 h	≈ 5 / 4 h
Permanent Magnet Synchronous Motor	●	●	●	●	●
Peak power 20 kW / 27 hp	●	●	●	●	●
Peak torque 112 N.m	●	●	●	●	●
Rear-wheel drive	●	●	●	●	●
Regenerative braking system	●	●	●	●	●
Suspension Front / Rear	McPherson / Leaf Spring	McPherson / Leaf Spring	McPherson / Leaf Spring	McPherson / Leaf Spring	McPherson / Leaf Spring
Brakes Front/Rear	Disc / Drum	Disc / Drum	Disc / Drum	Disc / Drum	Disc / Drum
Tire 155R13C (LT)	●	●	●	●	●
Hand Brake	●	●	●	●	●
<b>CARGO PLATFORM</b>					
Cargo volume	3 m <sup>3</sup>	2.8 m <sup>3</sup>	2.3 m <sup>2</sup>	2.2 m <sup>2</sup>	2.2 m <sup>2</sup>
Cargo payload	500 kg / 590 kg	380 kg / —	500 kg / 590 kg	500 kg / 580 kg	500 kg / 580 kg

**DISCLAIMER:**

The battery pack capacity may/will degrade over time and usage. The actual driving range will vary depending on driving behaviors, charging intervals, driving speed, cargo load weight and weather conditions.

The figures shown are for comparability purposes; only compare with other vehicles tested to the same technical procedures and similar vehicle weight class. The charging times are estimates. Charging stations must be Type 2 compatible. The permissible total cargo weight must not exceed. Technical specifications and data are valid at the time of publishing. The product images shown are for illustrative purposes only. Specifications are subject to change without prior notice.