



# 台泉牌

## 同軸渦卷泵

經濟部標準檢驗局 ISO 9001 認證合格工廠

抽水量大適合於各型工業、空調給水、  
農業灌溉用水、消防給水、土木施工用水、  
鍋爐給水、污水處理設備等。



ISO 9001 證書





# 高性能·高效率·低出力·省能源

## 優點簡介：

1. 經濟理想：係經過渦流式抽水機改良連體構造2極高性能特殊馬達所以免用多段抽水機。
2. 特選材質：抽水機內部採用機械軸封裝配，保證不漏水不損軸心，免入棉紗麻煩，延長抽水機壽命，馬達特製軸心不銹鋼，葉輪採用高性能鉑金銅、經過平衡、均嚴試驗。
3. 裝置容易：水機體積小所占的面積小，無論在傾斜面垂直或層頂上，甚至狹窄地方都能裝置，任何方向自由調換。
4. 牢固耐用：馬達、水機同軸連體，不發生偏心搖的現象，轉動時靜肅無聲，體型輕巧，操作簡單起動方便。
5. 用途廣泛：抽水量大適合於各型工業，冷卻循環給水、農業灌溉用水、都市學校給水、醫院給水、高樓給水、消防給水、土木施工用水、鍋爐給水、污水處理設備等。
6. 維護簡便：經過嚴密品質管制與精良的技術配合生產，所以各部構造均極精密完善，決無故障率發生，抽水機本身不需潤滑油及換綿紗，故維護費簡便。

## 剖面圖 CROSS SECTION OF MODEL

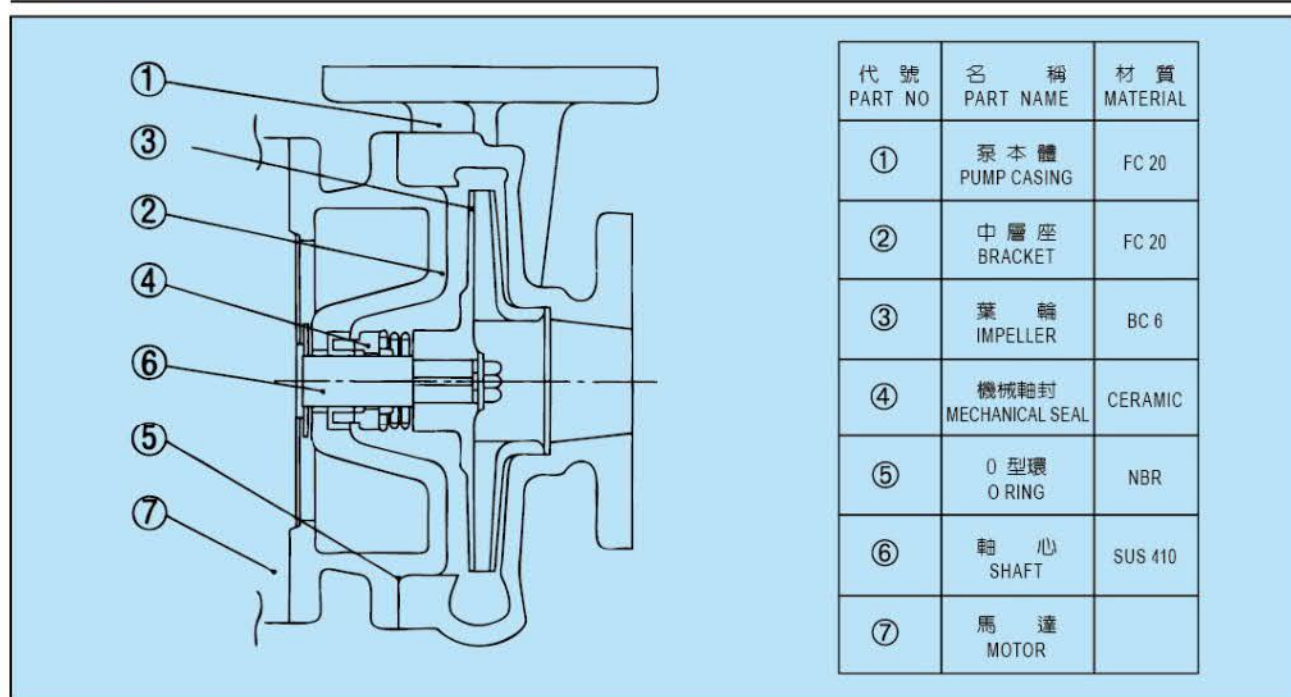

## 適用基準：

吸取液：0°~60°C的清水，PH6~8，上記以上的高溫和特殊液不得使用。

使用清水以外的場合，液體的性狀（溫度、濃度、固形物的有無）與使用條件，足以引起耐磨耗性，耐蝕性大幅變化時，敬請照會本公司。

吸力：液的溫度0~40°C。吸入全揚—6M以內。（吸入全揚程容許值）

標準材質：泵體...FC20，主軸...SUS410J2 葉輪...BC6

選擇材質：泵體...SUS304、316、主軸304、316、葉輪...SUS304、316

## Applicable Standard:

Sucking Liquid : 0°~60°C clean water, PH 6~8. The high temperature over the above and unusual liquid can not be used. In the area other than clean watet, when the liquid's nature, form (temperature, density, with or without solid) and using condition can cause great change in anti-friction and anti-erosion, please let us know.

Suction : Sucking the allowable value of all head. Temperature of liquid 0~40°C, Sucking all head — 6M.

Standard of Material : Pump...FC20, Main shaft...SUS420J2 Impeller shaft...BC6

Choice Material : Pump...SUS304、316, Main shaft...SUS304、316, Impeller shaft...SUS304、316





# 同軸渦卷泵浦尺寸圖

## Dimension Chart of Same-shaft Volute Pump

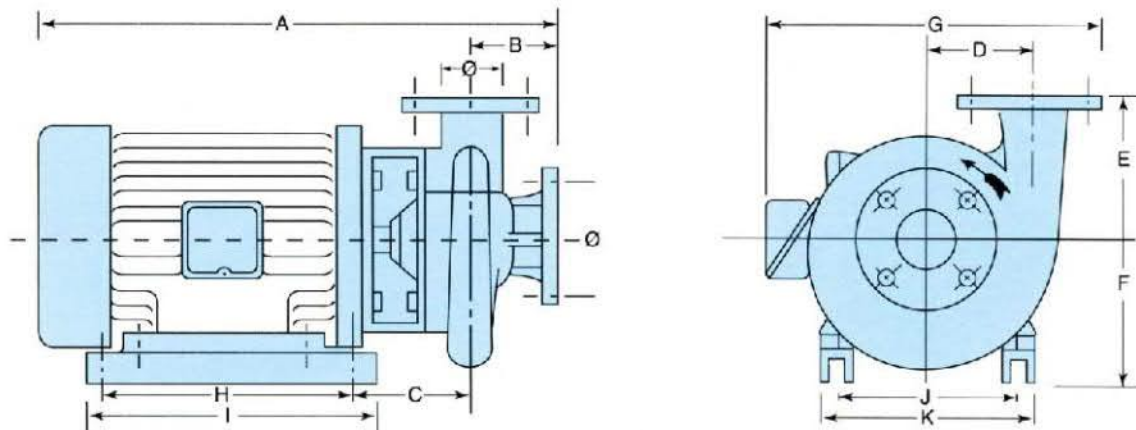

三相採用東元、大同馬達 單相採用台泉馬達

(2 Pole)

型號 TYPE	三相外型尺寸圖 (單位m/m)											略重 KG	備註 Remarks
	A	B	C	D	E	F	G	H	I	J	K		
FA05R25	350	50	70	60	110	86	235	200	230	110	145	16	
FA0125	370	50	85	65	118	95	260	200	230	125	160	21	
FA0140	370	50	85	65	118	95	260	200	230	125	160	21	
FJ0240	415	55	100	75	125	105	280	200	230	140	175	28	
FA0250	415	57	100	80	130	105	290	200	230	140	175	30	
FA0340	415	60	95	80	130	105	290	200	230	140	175	34	
FJ0350	415	60	95	80	130	105	290	200	230	140	175	34	
FA0365	430	66	100	90	130	105	310	200	230	140	175	38	
FJ0550	495	70	75	100	150	140	360	265	300	190	240	55	
FA0565	495	75	80	90	155	140	360	265	300	190	240	58	
FA0580	495	75	80	90	155	140	360	265	300	190	240	58	
FJ7R580	560	75	125	120	162	160	430	265	300	216	266	82	
FA7R5100	570	92	115	110	175	160	415	265	300	216	266	93	
FJ1080	560	75	125	120	162	160	430	265	300	216	266	95	
FA10100	570	92	115	110	175	160	415	265	300	216	266	103	
FJ1580	685	75	120	120	162	230	485	350	400	255	295	139	
FA15100	700	90	120	145	190	230	500	350	400	255	295	156	
FA15125	715	100	130	125	195	230	500	345	400	255	295	160	
FJ2080	685	80	120	140	230	230	485	350	400	255	295	168	
FA20100	700	90	120	145	190	230	500	350	400	255	295	173	
FA20125	715	100	130	125	195	230	500	350	400	255	295	178	
FA20150	750	115	150	150	215	230	550	350	400	255	295	180	
FJ25100	800	90	170	150	220	230	500	420	470	255	295	192	
FA25150	850	115	190	150	215	230	540	420	470	255	295	195	
FJ30100	800	90	140	150	220	280	535	490	550	290	340	230	
FA30150	855	115	170	150	215	280	580	490	550	290	340	242	
FJ40100	870	100	170	145	190	280	560	490	550	290	340	285	
FA40150	900	120	180	165	255	280	610	490	550	290	340	298	
FA50100	930	100	180	170	230	325	625	540	600	320	380	382	
FA50150	960	120	190	165	255	325	680	540	600	320	380	390	
FA60100	930	100	180	170	230	325	625	540	600	320	380	415	
FA60150	960	120	190	165	255	325	680	540	600	320	380	430	
FA75150	1005	120	205	165	255	325	740	540	600	355	405	510	
FA100150	1100	110	245	220	270	350	800	540	600	405	455	715	
型號 TYPE	單相外型尺寸圖 (單位m/m) (單位m/m)											略重 KG	備註 Remarks
	A	B	C	D	E	F	G	H	I	J	K		
BA05R25	370	50	70	60	110	95	235	200	230	125	160	21	
BA0140	425	50	95	65	120	105	270	200	230	140	175	30	
BA0250	440	57	105	80	130	105	315	200	230	140	175	42	

# 4P 同軸式性能曲線表

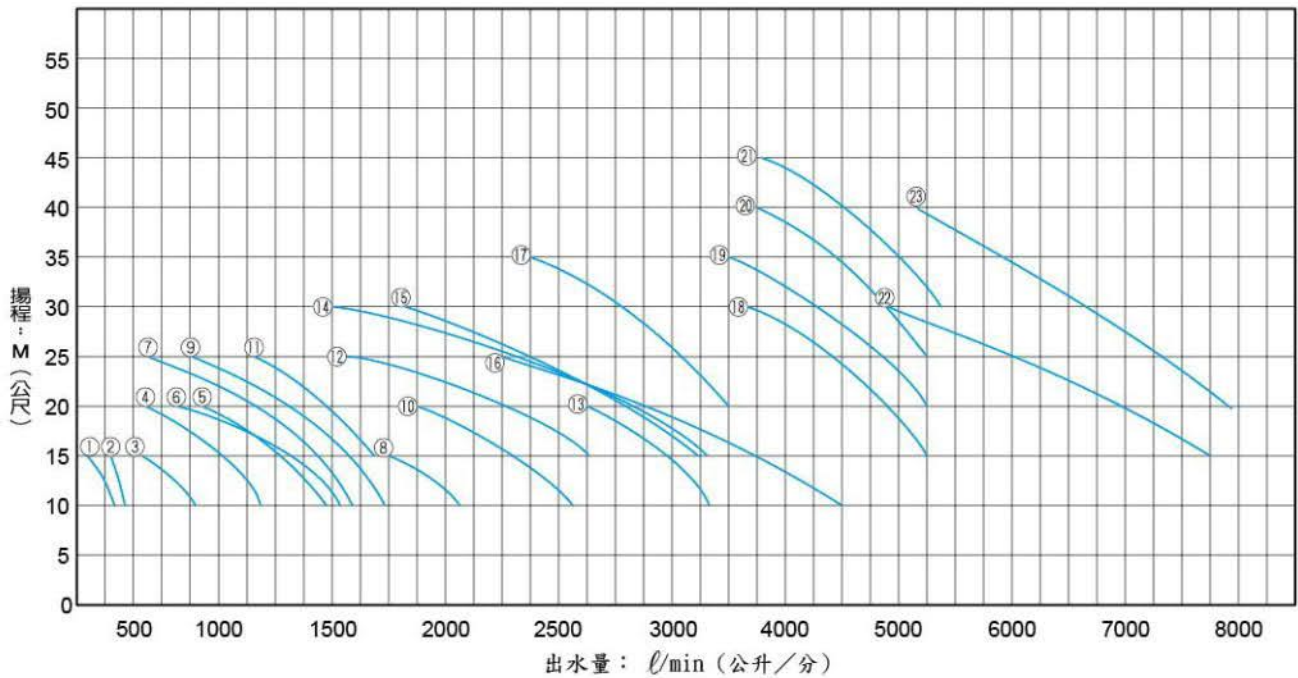

高性能同軸式三相性能規格表 3-Phase specification form on same shaft of high performance																			
項目	型式 (TYPE)	馬力 (HP)	口徑 (IN)	極數 (P)	總揚程 (H)=米 (M)						出水量(Q)=公升/分(L/MIN)						價格		備註
					10	15	20	25	30	35	40	45	50	55	60	鑄鐵	白鐵不銹鋼		
1	FP0250	2	2"	4	370	220													
2	FP0365	3	2½"	4	565	380													
3	FP0580	5	3"	4	880	570													
4	FP7R580	7½	3"	4	1310	1090	585												
5	FP7R5100		4"	4	1540	1210	895												
6	FP1080	10	3"	4	1410	1120	710												
7	FP10100		4"	4	1550	1390	1135	730											
8	FP10125		5"	4	2100	1730													
9	FP15100	15	4"	4	1755	1530	1280	830											
10	FP15125		5"	4	2630	2130	1730												
11	FP20100	20	4"	4		1750	1510	1240											
12	FP20125		5"	4		2680	2210	1610											
13	FP20150		6"	4	3420	3210	2710												
14	FP25150	25	6"	4		3400	2930	2370	1530										
15	FP30150	30	6"	4		3470	3210	2680	1800										
16	FP30200		8"	4	4650	4410	3790	2250											
17	FP40150	40	6"	4			3460	3190	2930	2400									
18	FP40200		8"	4		5210	4670	4500	3870										
19	FP50200	50	8"	4			5145	4700	4315	3860									
20	FP60200	60	8"	4				5160	4760	4440	3730								
21	FP75200	75	8"	4					5400	4890	4530	3815							
22	FP75250		10"	4		7820	7140	6475	5730	4975									
23	FP100250	100	10"	4			7900	7250	6610	5870	5100								



# 同軸低噪音渦卷泵浦尺寸圖

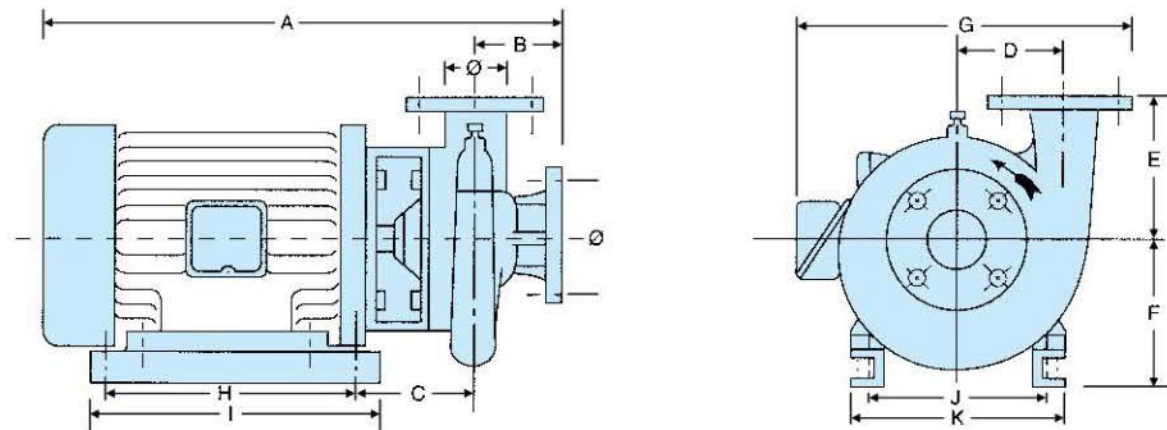

4P 同軸低噪音渦卷泵浦外型尺寸圖

(4 Pole)

型號 TYPE	三相外型尺寸圖(單位m/m)											略重 KG	備註 Remarks
	A	B	C	D	E	F	G	H	I	J	K		
FP0250	430	60	100	160	175	190	400	200	250	140	185	47	
FP0365	460	60	110	160	175	200	420	200	250	160	205	58	
FP0580	505	80	110	140	190	212	440	200	250	185	230	70	
FP7R580	580	90	105	150	220	202	450	350	400	215	255	105	
FP7R5100	580	90	105	150	220	202	450	350	400	215	255	105	
FP1080	610	90	110	150	220	202	450	350	400	215	255	116	
FP10100	610	90	110	150	220	202	450	350	400	215	255	116	
FP10125	635	115	120	160	230	232	500	330	380	220	270	128	
FP15100	710	100	120	175	230	230	540	350	400	255	290	173	
FP15125	720	115	120	160	230	230	540	350	400	255	290	185	
FP20100	760	105	115	170	250	260	550	490	550	260	315	195	
FP20125	770	115	110	160	230	230	560	420	470	255	295	210	
FP20150	780	120	120	165	255	230	580	420	470	255	295	218	
FP25150	850	110	160	220	270	280	660	490	550	290	345	265	
FP30150	850	110	160	220	270	280	660	490	550	290	345	294	
FP30200	870	140	165	215	260	280	670	490	550	290	345	320	
FP40150	910	130	180	230	240	280	670	490	550	290	345	348	
FP40200	920	140	180	215	260	280	670	490	550	290	345	365	
FP50200	980	140	200	215	260	325	700	540	600	320	380	410	
FP60200	980	140	200	215	260	325	700	540	600	320	380	465	
FP75200	1000	140	190	215	260	325	720	590	650	390	430	540	
FP75250	1000	150	190	220	320	325	780	590	650	390	430	590	
FP100250	1120	150	190	220	320	350	810	590	650	420	460	780	

內容規格如有變更，恕不另行通知。

2014/08製