

1 100kWh Air-Cooled Energy Storage System

Product Introduction:

The 100kWh air-cooled energy storage system (Model: CEIC-W-100kWh-50kW) internally integrates DCDC energy storage/photovoltaic-side voltage transformation, supporting connection to photovoltaic systems. It is capable of Real-time monitoring of smoke and temperature, along with multiple-point real-time monitoring by BMS and EMS to ensure the system's safe and reliable operation. The EMS system enables the storage, transfer and exchange of energy between the storage device, the photovoltaic system, the grid and the load, thus optimizing the energy, improving the stability of the power supply system and the quality of the power supply.

Product Features:

- Modular design with flexible configuration
- Intelligent Energy Management System (EMS) with multiple management strategies
- Seamless switching between STS and off-grid operation
- Integrated components such as DC/DC, supporting photovoltaic integration
- Battery system with hierarchical management, real-time monitoring, and dual-layer thermal insulation design
- Multiple intelligent safety systems
- Professional design and one-stop service



Product Parameters

Parameter	Parameter specification
Inverter	
Specification	50kW
DC Voltage Range	560~850V
Max. DC Current	90A
AC Voltage Range	320~460V
Norminal Frequency	50/60Hz (±5adaptive)
Connection Method	3P3L / 3P4L
Rated Current	72A
AC Voltage Harmonics	<3% (linear load)
Protection	Battery anti-reverse connection, DC overcurrent protection, AC overcurrent protection, AC overvoltage protection, surge protection
Battery Module Technical Specification	
Weight	110kg
Dimension (W/D/H)	418x770x235mm
Max. Charge/Discharge Current	140A
Battery Capacity	14.336kWh
Nominal Battery Voltage	51.2V
Number of Cycles	≥6000@ (25°C)
Accreditations	The internal module has the following certifications: IEC62619, IEC61000, UN38.3+MSDS+ sea freight
General Data	
Dimension (W/D/H)	1350x1050x2080mm
Total Weight (with battery)	1.25t
Weight without Battery	0.35t
Ingress Protection	IP54
Rated Power	50kW
System Capacity	100.352kWh (MAX)
Battery Type	LiFePO ₄
Cooling	Air Conditioner
Application	Outdoor
Operating Temperature	-30°C~+50°C
Design Life	More than 10 years

Main Application Scenarios:

- Peak-valley price arbitrage
- Maximize the utilization of solar energy to reduce carbon emissions
- Enhance power supply stability
- Dynamic expansion of distribution systems
- Microgrid systems

Reference electrical topology diagram

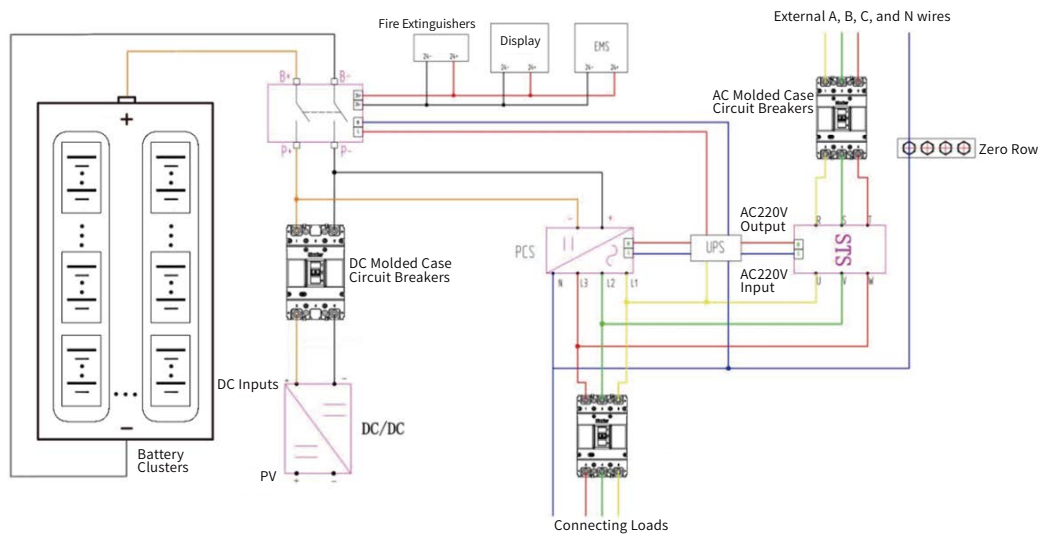

Order Information

Model	Basic Configuration	Lead Time
CEIC-W-100kWh-50kW-DCDC	100kWh, 50kW, compatible with PV input	20days
CEIC-W-100kWh-50kW	100kWh, 50kW, not compatible with PV input	20days
Other power specifications can be customized		